

**AFRICAN TRADITIONAL MEDICINES-ANTIRETROVIRAL DRUG
INTERACTIONS: THE EFFECT OF AFRICAN POTATO (*HYPOXIS
HEMEROCALLIDEA*) ON THE PHARMACOKINETICS OF EFAVIRENZ IN
HUMANS**

by

Seloi Mogatle

A thesis submitted in fulfilment of the requirements for the degree of

MASTER OF SCIENCE (PHARMACY)

November 2008

Faculty of Pharmacy
Rhodes University
Grahamstown

ACKNOWLEDGEMENTS

I would like to dedicate this thesis to my grand parents: Rahube & Kenaope Kgatitswe and Moloji & Mekgwenyane Mogatle.

I would like to express my sincere thanks to the following people:

My supervisor, Prof Isadore Kanfer, for giving me the opportunity to conduct this important research and for the patience, support and encouragement throughout the course of my studies.

The Dean and Head, Prof R. B. Walker and the staff of the Faculty of Pharmacy, for the use of the facilities in the Faculty and the encouragement they provided.

My colleagues in the Biopharmaceutics Research Laboratory (Ralph Tettey-Amlalo, Nyaradzo Mandimika, Faith Chaibva and Wai Ling Au), thank you very much for the support you gave me. To all my friends in particular Ntsetselele Damen Kago, Matsheliso Kgosidialwa, Reginah Molelekwa thank you for the emotional support and being there for my children during my absence.

My parents, Keitirang and Seipone and for looking after my babies and supporting me throughout the years, and to my sisters and brother, I thank you all for your understanding and for supporting me without any complaints. My children, Reagile and Wecho-Basiame, for allowing me to leave them at home to pursue my studies.

To Moncho my partner, thank you for encouraging me to pursue my studies and for the emotional support and guidance.

I would like to give thanks to Almighty God for giving me strength to carry on and preserving my health.

ABSTRACT

African Potato (*Hypoxis hemerocallidea*), (AP) is an African traditional medicine (TM) that is commonly used for various nutritional/medicinal purposes and also by people infected with the human immuno deficiency virus HIV and AIDS patients as an immune booster. The use of AP has also been recommended by the former Minister of Health of South Africa for use by HIV positive people. The main phytochemical component of AP is a norlignan glucoside, hypoxoside, and other relatively minor components have also been reported. A recent *in vitro* study reported the effects of AP extracts, hypoxoside and rooperol (the metabolite of hypoxoside) on human metabolic enzymes such as the cytochrome P₄₅₀ (CYP450) group of enzymes and also on the transporter protein, p-glycoprotein (P-gp). This research focussed on investigating the clinical significance of those *in vitro* effects on the pharmacokinetics of efavirenz (EFV) in humans. EFV was chosen as the substrate drug because it is in first-line regimen of treatment of HIV/AIDS in South Africa, and also has been reported to be a substrate for the specific CYP isozymes, 3A4 and 2B6, in common with APs metabolic involvement with 3A4.

A high performance liquid chromatography method with ultra-violet detection (HPLC-UV) for the quantitative determination of EFV in plasma was developed and successfully validated according to international standards with good reproducibility, accuracy, recovery, linear response and requisite sensitivity. The preparation of the plasma samples for analysis was effected by using a simple and rapid precipitation method, and the mobile phase consisted of readily available solvents. EFV in plasma samples was found to be stable under the relevant storage conditions studied. The oral dose of AP, administered as a freshly prepared traditional decoction, was standardised based on the hypoxoside content, and the quality of all the AP decoctions was analysed immediately prior to administration, using a validated HPLC-UV method.

A single dose, two-phase sequential study was conducted over a period of 31 days in 10 healthy volunteers. The clinical study was approved by the Rhodes University Ethical Standards Committee, and all the participants agreed to the conditions of the study by giving their informed consent. On day 1 of the study, human subjects were administered a 600 mg EFV tablet and blood samples were collected before dosing and at various intervals over a period of 48 hr post dosing. From day 16, a traditionally prepared AP decoction was

administered daily at a standardized dose of 15 mg/kg/day per subject until day 30. On day 29, volunteers were administered a single 600 mg dose of EFV as was done on day 1. Plasma samples were harvested immediately after blood sample collection and frozen at -80 °C until assayed. Geometric mean ratios of relevant pharmacokinetic parameters, C_{\max} (maximum plasma concentration achieved following dosing) and AUC_{0-48} (area under the curve of a plot of drug plasma concentrations versus time representing the extent of absorption) of EFV before and after co-administration of 14 successive daily doses of AP were compared and evaluated to determine whether an interaction had occurred. All subjects completed the study and the geometric mean ratios of C_{\max} and AUC_{0-48} were 97.30 and 102.82 with corresponding 90% confidence intervals (CIs) of 78.81-120.14% and 89.04-118.80%, respectively. Whereas the acceptance criteria for the ratios of the AUCs fell within the preset 90% CIs indicating no interaction, the C_{\max} ratios fell outside the limits. Although the protocol was developed in accordance with the United States of America Food & Drug Administration's Guidance for Drug Interactions, *a priori* stating that both criteria need to fall within the acceptance limits to indicate no interaction, an argument is presented to waive the C_{\max} requirement for the declaration of an interaction. As a result, the pharmacokinetic data generated during this study indicated that the effect of AP on the pharmacokinetics of EFV is not clinically significant. Hence, co-administration of AP is unlikely to affect the clinical use of EFV.

In summary the objectives of this project were:

1. To develop and validate a suitable HPLC-UV method for the quantitative determination of EFV in plasma.
2. To perform a mini-validation of the determination of hypoxoside for use as a marker in the quality control and standardisation of AP decoctions.
3. To conduct a clinical interaction study in order to determine whether AP affects the pharmacokinetics of EFV following concurrent administration.
4. To apply the validated HPLC-UV method to determine plasma concentrations of EFV in plasma of human subjects.
5. To use appropriate statistical methods and treatments such as a non-compartmental pharmacokinetic analysis to determine the occurrence of an interaction.

TABLE OF CONTENTS

ACKNOWLEDGEMENTS	II
ABSTRACT	III
LIST OF FIGURES	IX
LIST OF TABLES	X
CHAPTER 1	1
1 HUMAN IMMUNODEFICIENCY VIRUS INFECTION AND TREATMENT	1
1.1 VIRAL TAXONOMY	1
1.2 VIRAL MORPHOLOGY	2
1.3 PATHOPHYSIOLOGY OF HIV INFECTION	3
1.3.1 ACUTE INFECTION.....	3
1.3.2 CHRONIC LATENT STAGE.....	4
1.3.3 AIDS	4
1.4 EPIDEMIOLOGY	4
1.5 TREATMENT OF HIV/AIDS.....	5
1.5.1 ORTHODOX MEDICINES	6
1.5.2 TRADITIONAL MEDICINES.....	7
1.6 HIV/AIDS AND TMs	12
1.6.1 BACKGROUND.....	12
1.6.2 SAFETY OF TMs	15
1.7 DRUG-TM INTERACTIONS	16
1.7.1 PHARMACODYNAMIC INTERACTIONS	16
1.7.2 PHARMACOKINETIC INTERACTIONS.....	16
1.7.3 IN VITRO STUDIES: HYPOXIS HEMEROCALLIDEA.....	21
CHAPTER 2	23
2 EFAVIRENZ AS AN ANTIRETROVIRAL AGENT.....	23
2.1 INTRODUCTION.....	23
2.2 SYNTHESIS.....	23
2.3 PURITY	23
2.4 PHYSICOCHEMICAL PROPERTIES OF EFV.....	24
2.4.1 SOLUBILITY.....	24
2.4.2 ULTRAVIOLET (UV) ABSORPTION	24
2.4.3 DESCRIPTION.....	24
2.4.4 MELTING POINT AND pKa	25
2.4.5 POLYMORPHISM.....	25
2.4.6 STEREOCHEMISTRY.....	25
2.5 STABILITY	25
2.6 PHARMACOLOGICAL ACTIVITY OF EFV	26
2.6.1 MODE OF ACTION	26
2.7 MUTATIONS AT THE NNBP	29

2.7.1	TYPES OF MUTATIONS	29
2.7.2	FACTORS AFFECTING MUTATIONS	30
2.8	HYPER-SUSCEPTIBILITY TO EFV	30
2.9	PHARMACOKINETICS OF EFV	30
2.9.1	ABSORPTION	30
2.9.2	EFFECT ON P-GLYCOPROTEIN	31
2.9.3	DISTRIBUTION	31
2.9.4	METABOLISM AND ELIMINATION	32
2.10	DRUG INTERACTIONS OF EFV	34
2.10.1	EFV AS A SUBSTRATE OF CYP3A4	34
2.10.2	INDUCTION OF CYP3A4.....	35
2.10.3	INHIBITION OF CYP3A4.....	36
2.11	EFFICACY	36
2.12	CLINICAL USES	37
2.13	SIDE EFFECTS	37

CHAPTER 3 **38**

3 AFRICAN POTATO AND DRUG INTERACTIONS..... 38

3.1	GEOGRAPHICAL DISTRIBUTION	38
3.2	TAXONOMY	38
3.3	USES.....	40
3.4	CHEMICAL CONSTITUENTS.....	40
3.4.1	HYPOXOSIDE	41
3.4.2	OBTUSIDE A AND B.....	42
3.4.3	NYASOSIDE	42
3.4.4	NYASIDE.....	42
3.4.5	MONONYASINE A AND B	43
3.4.6	OBTUSASIDE.....	43
3.4.7	NYASOL.....	43
3.4.8	STEROLS AND STEROLINS	44
3.5	PHARMACOLOGICAL ACTIVITY OF AP.....	44
3.5.1	IMMUNOMODULATION PROPERTIES.....	44
3.5.2	ANTIOXIDANT ACTIVITY	44
3.5.3	ANTI-INFLAMMATORY PROPERTIES.....	45
3.5.4	ANTINOCICEPTIVE PROPERTIES	45
3.5.5	ANTIDIABETIC/HYPOGLYCAEMIC EFFECTS	46
3.5.6	ANTICONVULSANT ACTIVITY	46
3.5.7	ANTIBACTERIAL ACTIVITY	46
3.6	PHARMACOKINETICS	47
3.6.1	ABSORPTION	47
3.6.2	METABOLISM AND ELIMINATION	48
3.7	CLINICAL STUDIES	48
3.8	SAFETY OF <i>HYPOXIS HEMEROCALLIDEA</i>	50
3.9	<i>IN VITRO</i> DRUG INTERACTION STUDIES	50
3.10	REGISTERED PATENTS	51

CHAPTER 4 **52**

4 HIGH PERFORMANCE LIQUID CHROMATOGRAPHY (HPLC) METHODS FOR AFRICAN POTATO (*HYPOXIS HEMEROCALLIDEA*) AND EFAVIRENZ..... 52

4.1 BACKGROUND	52
4.1.1 RESOLUTION	52
4.1.2 COLUMN EFFICIENCY.....	53
4.1.3 CAPACITY FACTOR	54
4.1.4 SELECTIVITY	55
4.1.5 TAILING FACTOR.....	56
4.2 APPLICATION OF HPLC	56
4.3 QUANTITATIVE ANALYSIS OF HYPOXOSIDE IN AFRICAN POTATO DECOCTIONS	57
4.3.1 INTRODUCTION	57
4.3.2 EQUIPMENT AND REAGENTS	59
4.3.3 CHROMATOGRAPHIC CONDITIONS.....	59
4.3.4 METHODS	59
4.3.5 RESULTS AND DISCUSSION	59
4.3.6 CONCLUSIONS	61
4.4 DEVELOPMENT AND VALIDATION OF A HPLC METHOD FOR THE DETERMINATION OF EFAVIRENZ IN HUMAN PLASMA	61
4.4.1 INTRODUCTION	61
4.4.2 REVIEW OF PUBLISHED METHODS	62
4.4.3 METHODS	65
 CHAPTER 5	 85
 5 IN VIVO INTERACTIONS BETWEEN EFAVIRENZ AND AFRICAN POTATO (HYPOXIS HEMEROCALLIDEA)	 85
 5.1 CLINICAL TRIAL DESIGN	 86
5.1.1 PARALLEL DESIGN	87
5.1.2 CROSSOVER DESIGNS.....	87
5.2 DRUG INTERACTION STUDY DESIGNS	88
5.2.1 STUDY POPULATION AND SAMPLE SIZE	88
5.2.2 WASHOUT PERIOD	88
5.3 ANALYSIS OF PHARMACOKINETIC DATA	89
5.3.1 PHARMACOKINETIC ANALYSIS	89
5.3.2 STATISTICAL ANALYSIS.....	89
5.4 METHODS AND PROCEDURES	92
5.4.1 ETHICAL AND INSTITUTIONAL REVIEW	92
5.4.2 STUDY POPULATION	92
5.4.3 STUDY DESIGN.....	96
5.4.4 ANALYSIS OF PLASMA SAMPLES	98
5.4.5 PREPARATION OF AFRICAN POTATO DECOCTION.....	98
5.4.6 ANALYSIS OF AP DECOCTION.....	98
5.4.7 DOSING OF AP DECOCTION	99
5.4.8 DATA ANALYSIS	99
5.5 RESULTS	100
5.5.1 AP DECOCTION PREPARATIONS AND ANALYSES	100
5.5.2 PLASMA EFV ANALYSIS	100
5.5.3 PHARMACOKINETIC AND STATISTICAL PARAMETERS	102
5.6 DISCUSSION	102
5.7 CONCLUSIONS	104
 CONCLUDING REMARKS	 111

ANNEXURES.....	112
STUDY PROTOCOL	113
RAW DATA OF SUBJECT SAMPLE ANALYSIS	116
REFERENCES.....	117

LIST OF FIGURES

FIGURE 1.1. AN ILLUSTRATION OF HIV CLASSIFICATION.	1
FIGURE 1.2. LIFE CYCLE OF HIV IN HUMANS [7].	3
FIGURE 1.3. GLOBAL PREVALENCE OF HIV INFECTIONS IN 2007 [2].	5
FIGURE 1.4. TREND OF AVAILABILITY OF ARVs IN SUB-SAHARAN AFRICA [2].	13
FIGURE 1.5. DIAGRAMMATIC REPRESENTATION OF P-GLYCOPROTEIN-MEDIATED DRUG EFFLUX [80].	20
FIGURE 2.1. CHEMICAL STRUCTURE OF EFV.	23
FIGURE 2.2. UV SPECTRUM OF EFV.	24
FIGURE 2.3. MECHANISM OF HYDROLYSIS OF EFV [91].	26
FIGURE 2.4. DIAGRAM OF THE HIV-1 RT HETERODIMER IN THE COMPLEX WITH AN NNRTI [96].	27
FIGURE 2.5. PROPOSED METABOLIC PATHWAY FOR EFV IN HUMANS [109].	33
FIGURE 3.1. PHOTOGRAPH OF A YOUNG <i>HYPOXIS HEMEROCALLIDEA</i> PLANT [161].	39
FIGURE 3.2. STRUCTURES OF HYPOXOSIDE, OBTUSIDE A AND OBTUSIDE B.	41
FIGURE 3.3. CHEMICAL STRUCTURE OF NYASOSIDE, NYASIDE, NYASOL, MONONYASINE A AND MONONYASINE B.	42
FIGURE 3.4. CHEMICAL STRUCTURE OF OBTUSASIDE.	43
FIGURE 3.5. METABOLISM OF HYPOXOSIDE.	48
FIGURE 4.1. CHROMATOGRAPHIC SEPARATION OF TWO COMPOUNDS [202].	54
FIGURE 4.2. ILLUSTRATION OF INCREASING EFFICIENCY AND INCREASING SELECTIVITY [202].	55
FIGURE 4.3. UV ABSORPTION SPECTRUM OF HYPOXOSIDE.	60
FIGURE 4.4. CHROMATOGRAM OF CALIBRATION STANDARD OF HYPOXOSIDE WITH SMZ.	61
FIGURE 4.5. CHROMATOGRAM OF EFV PEAKS DISSOLVED IN ACN (BLUE), MeOH (RED) AND MP (GREEN).	68
FIGURE 4.6. A CHROMATOGRAM OF A SPIKED PLASMA SAMPLE CONTAINING EFV (RED: $\lambda=247$ NM) AT A CONCENTRATION OF 1.5 μ G/ML AND IS (GREEN: $\lambda=275$ NM) AT A CONCENTRATION OF 4.0 μ G/ML.	68
FIGURE 4.7. A BLANK PLASMA EXTRACT (GREEN) AND SPIKED PLASMA SAMPLE CONTAINING EFV AND FLU AS IS (RED - $\lambda=247$ NM).	73
FIGURE 4.8. A BLANK PLASMA EXTRACT (RED) AND A SPIKED PLASMA SAMPLE CONTAINING EFV AND DICNA AS IS (GREEN: $\lambda=275$ NM).	73
FIGURE 4.9. A BLANK PLASMA EXTRACT (RED - $\lambda=247$ NM AND GREEN - $\lambda=275$ NM) AND B = SPIKED PLASMA SAMPLE CONTAINING EFV (RED: $\lambda=247$ NM) AT THE LLOQ AND IS (GREEN: $\lambda=275$ NM) AND (C) PLASMA OF A VOLUNTEER TWO HOURS AFTER THE ORAL ADMINISTRATION OF A 600 MG EFV TABLET TO A HUMAN SUBJECT.	79
FIGURE 4.10. EFV AT MID QC AND IS IN MOBILE PHASE SOLUTION (GREEN) AND PLASMA SAMPLES SPIKED WITH EFV AT MID QC AND IS (RED) MONITORED AT $\lambda=247$ NM.	81
FIGURE 5.1. MEAN AND SD OF PLASMA CONCENTRATION VS TIME OF EFV ALONE AND EFV CO-ADMINISTERED WITH AP.	101

LIST OF TABLES

TABLE 1.1. ANTIRETROVIRAL DRUG CLASSES.	7
TABLE 1.2. ANTIRETROVIRAL PROPERTIES OF SOME PLANT EXTRACTS.	14
TABLE 1.3. CLINICAL STUDIES OF INTERACTIONS BETWEEN TMs/CAMs AND ORTHODOX MEDICINES AND EFFECTS ON BIOAVAILABILITY.	18
TABLE 1.4. INTERACTIONS OF TM/CAM AND ORTHODOX MEDICINES INVOLVING P-GP.	21
TABLE 2.1. PHARMACOKINETIC INTERACTIONS OF EFV RESULTING FROM INDUCTION OF CYP450 ENZYMES.	35
TABLE 3.1. TRADITIONAL USES OF <i>HYPOXIS HEMEROCALLIDEA</i>	40
TABLE 4.1. DIFFERENT LIQUID CHROMATOGRAPHIC MODES.	56
TABLE 4.2. LINEARITY.	60
TABLE 4.3. REVIEW OF THE ANALYTICAL METHODS USED FOR THE DETERMINATION OF EFV IN HUMAN PLASMA.	63
TABLE 4.4. ACIDIC COMPOUNDS INVESTIGATED.	67
TABLE 4.5. EFFECT OF INJECTION VOLUME ON PEAK AREA.	70
TABLE 4.6. FINAL CHROMATOGRAPHIC CONDITIONS FOR THE DETERMINATION OF EFV.	70
TABLE 4.7. INTER-DAY ACCURACY.	78
TABLE 4.8. INTRA-DAY ACCURACY OF EXTRACTED PLASMA SAMPLES.	80
TABLE 4.9. INTRA-DAY PRECISION.	82
TABLE 4.10. INTER-DAY PRECISION.	82
TABLE 4.11. CALIBRATION LINEARITY.	82
TABLE 4.12. SHORT-TERM STABILITY OF UNPROCESSED SAMPLES.	83
TABLE 4.13. LONG TERM STABILITY OF EFV IN PLASMA.	83
TABLE 4.14. SHORT-TERM STABILITY OF THE SAMPLES.	84
TABLE 5.1. DEFINITIONS OF PARAMETRIC ASSUMPTIONS.	90
TABLE 5.2. DEMOGRAPHIC DATA OF VOLUNTEERS.	93
TABLE 5.3. INCLUSION AND SELECTION CRITERIA.	94
TABLE 5.4. STUDY RESTRICTIONS.	97
TABLE 5.5. LINEARITY OF HYPOXOSIDE CALIBRATION CURVE AND CONCENTRATIONS OF AP DECOCTION.	101
TABLE 5.6. SUMMARY OF STATISTICS OF PHARMACOKINETIC PARAMETERS AND STATISTICAL ANALYSIS OF EFV ALONE AND EFV CO-ADMINISTERED WITH AP.	102

CHAPTER 1

HUMAN IMMUNODEFICIENCY VIRUS (HIV) INFECTION AND TREATMENT

1 HIV INFECTION

HIV is a retrovirus, which was first isolated in 1983 [1]. Infection with this virus can lead to the disease state, a syndrome called Acquired Immunodeficiency Syndrome (AIDS). In 2003 AIDS was declared a pandemic by the World Health Organisation (WHO). It is now the number one killer in the developing world [2].

1.1 Viral Taxonomy

There are two types of HIV, namely HIV-1 and HIV-2. The former is most common and is the organism responsible for the majority of infections worldwide. Progression to the disease state is much slower in HIV-1 infection compared to HIV-2. HIV-2 is rare and has only been isolated from people living in West Africa [3].

The HIV-1 is divided into groups M, N and O, but group classification is rarely used except in virology studies (Figure 1.1). Group M is further divided into subtypes A to J, where the most virulent of these is subtype C, which is characterised by rapid progression to the disease state. Subtype C is common in sub-Saharan region [4].

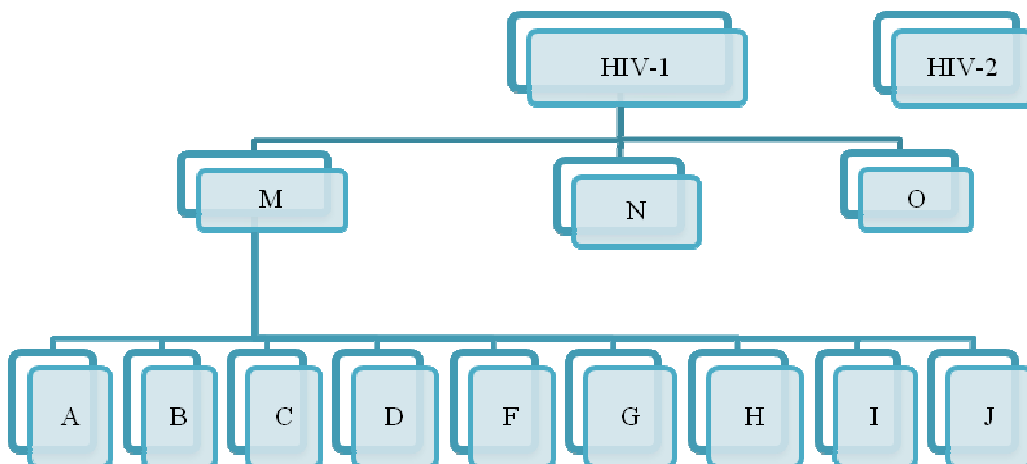

Figure 1.1. An illustration of HIV classification.

1.2 Viral Morphology

Virions, which are viral particles, consist of an external (surface) structure, on which is an envelope and an internal structure (Figure 1.2). The viral membrane on the envelope is lipid soluble and its surface is composed of envelope proteins gp-41 and gp-120 that are encoded by the *env* gene, and are highly glycosylated. Gp-41 is embedded in the membrane of the HIV particle, whereas gp-120 sits on the outside of the viral membrane. Gp-120 which has high affinity for the CD4 antigen, interacts with this antigen on the T-helper lymphocytes or macrophages. This interaction results in a conformational change on the gp-120, thereby exposing the sites that interact with the chemokine receptors (CCR5 or CXCR4). This uncovers the fusion protein, gp-41, resulting in another morphological change. The gp-41 then penetrates the membrane of the host cell.

The internal structure of the virus (viral core) is composed of a genome which consists of a diploid RNA, structural proteins and other proteins, and is separated from the external structure by protein coat material. The protein coat material is encoded by the *gag* gene. Internal proteins are encoded by the *pol* gene and the associated enzymes participate in integration and replication. These enzymes are reverse transcriptase (RT), protease and integrase. The RT enzyme has very little proof reading capacity (correction), therefore, errors can be incorporated into the proviral DNA during replication. Cells that are attacked by the virus are CD4 T4-helper cells (CD4+ T cells), Natural Killer cells, CD8 Killer T cells (CD8+ T cells), macrophages and dendritic cells. HIV continues to replicate in semen, forming a reservoir [5, 6].

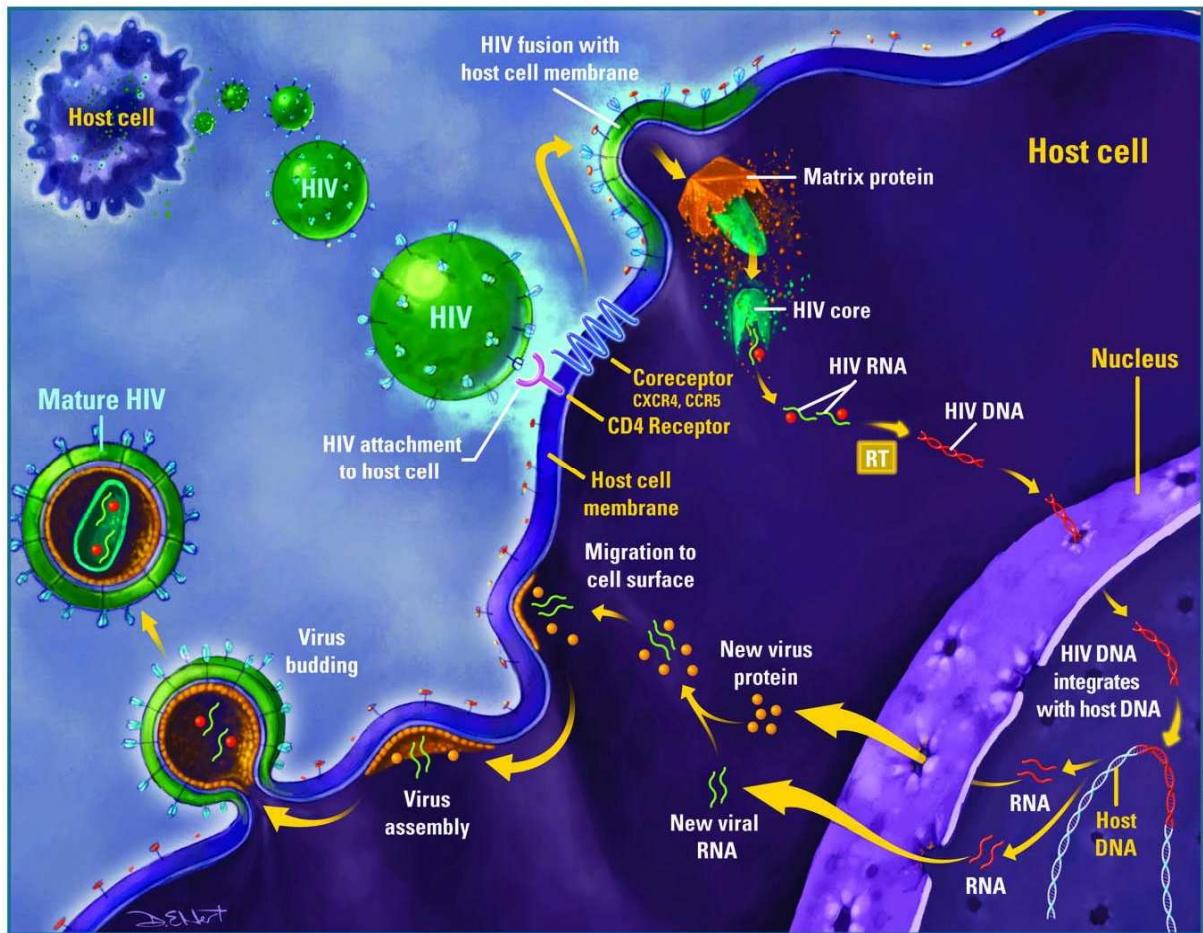

Figure 1.2. Life cycle of HIV in humans [7].

1.3 Pathophysiology of HIV Infection

1.3.1 Acute Infection

After infection with HIV some people will be asymptomatic, while others experience a flu-like illness characterised by fever, general malaise and sore throat within two to four weeks of infection. These symptoms usually last for about one to two weeks. Cells that are infected by HIV initially are the macrophages in semen or vaginal secretions. The macrophages then shed the viruses which bind to the dendritic cells. Immature dendritic cells develop into mature effector cells upon activation by microorganisms, and move to the draining lymph nodes where they stimulate inexperienced CD T helper cells. After the initial infection there is a decrease in CD4+ T cells and a rise in CD8+ T cells. The virus titres rise sharply, resulting in viraemia, which quickly returns to normal. Mucosal CD4+ T cells are lost during the early acute infection stage while others are lost later during chronic infection. The body

also responds by producing antibodies that are specific to the virus. This can take up to six months and this period is called the “window period” [8].

1.3.2 Chronic Latent Stage

The second stage of the infection is characterised by an immune response from cytotoxic B and T lymphocytes. In order to counteract the rapidly-replicating virus, the cell-mediated response increases. At this stage, the virus has a half-life of between 5 and 6 hr. Infected cells are destroyed either by the body’s immune system or by the virus. Some infected T4 cells can live longer and revert back to a resting memory stage. They will not express any viral antigens, and the genome inside can be reactivated by an antigen. These are known as memory cells and can survive for many years [8].

Viral particle numbers are then reduced by the strong immune response, resulting in latency. However, the virus continues to replicate in the lymph nodes. The viral particle count is used to measure the burden of infection.

1.3.3 AIDS

After the latency period which can last from 1 to 15 years, the immune system begins to fail to control the infection. The number of CD4+ T cells and dendritic cells diminish and the CD4+ T cells are used as markers of the stage of the infection. Loss of control over the virus results in immunosuppression which makes the body susceptible to infections by opportunistic bacteria, fungi, protozoa and viruses. At this stage, the virus replicates uncontrollably, and as there is no proofreading by the host DNA, hence mutations occur. These mutations can lead to treatment failures. This stage of the combination of HIV infection and AIDS is usually abbreviated as HIV/AIDS.

1.4 Epidemiology

It has been estimated that there are approximately 33 million people living with HIV in the world [2] (Figure 2.3). The majority (62.5%) of these infections are in Sub-Saharan Africa. In South Africa this percentage is estimated at 18.8% of the adult (15-49 years of age)

population, which means 5 300 000 people are infected with HIV. The number of people in South Africa who needed treatment in 2005 was 790 000 but only ~ 207 000 (23%) received therapy. The burden of disease (BOD) of AIDS in Africa has been estimated to be four times higher than in developed countries [9]. Most of the countries which have a high BOD because of HIV infection are middle- to low- income countries, and, therefore, the BOD can have negative effects on the economy of such countries [10].

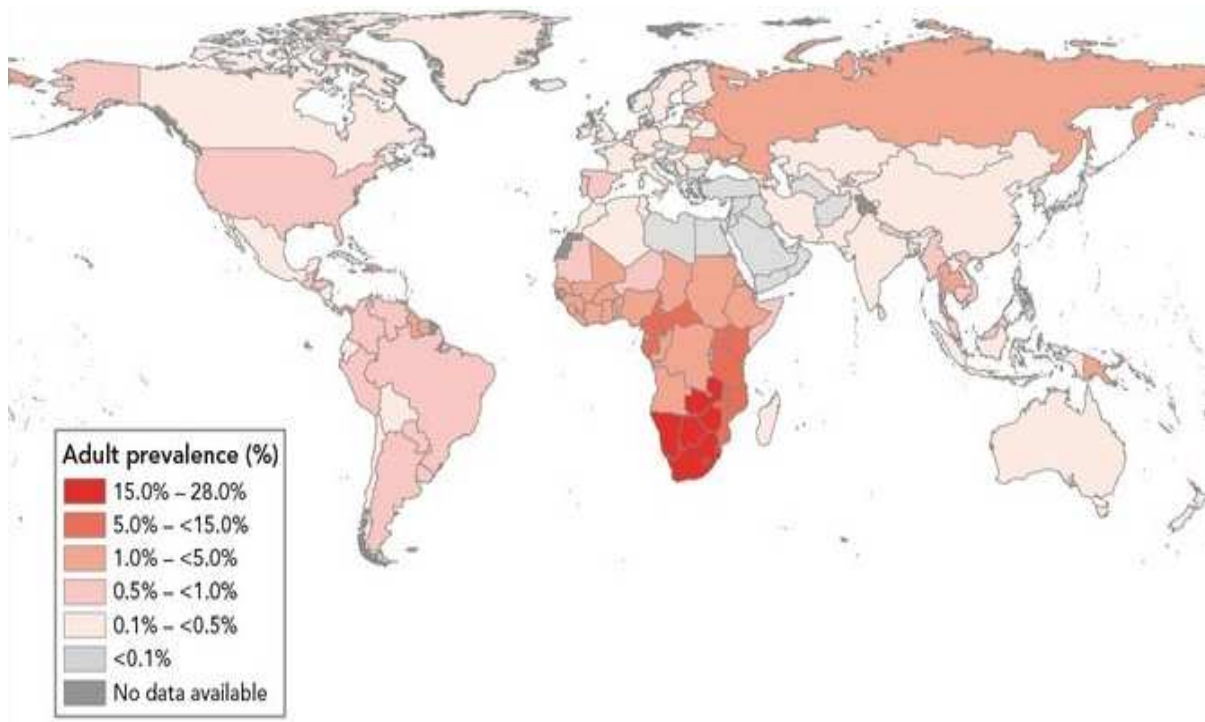

Figure 1.3. Global Prevalence of HIV infections in 2007 [2].

1.5 Treatment of HIV/AIDS

During the early 1990s, antiretroviral (ARV) drug treatments for HIV infection were introduced and more recently, various treatments involving new ARVs and combination therapy have been successfully used. Nonetheless, the efficacy of some ARVs has been reduced by mutations of the virus, leading to resistance. Due to these mutations, combination therapy, referred to as Highly Active Antiretroviral Therapy (HAART) is employed to reduce the viral load and increase the number of CD4+ T cells. Currently, national and international guidelines on HIV/AIDS treatment have been developed and, in addition, traditional medicines are also being used in the treatment and/or management of HIV/AIDS symptoms [10, 11].

1.5.1 *Orthodox Medicines*

The aim of HIV/AIDS treatment is to reduce HIV related illnesses (opportunistic infections), increase patient CD4+ T cell count and suppress viral replication to undetectable viral levels. There are six classes of ARVs, namely: nucleoside analogues/nucleotide reverse transcriptase inhibitors (NRTIs), non-nucleoside reverse transcriptase inhibitors (NNRTIs), protease inhibitors (PIs), fusion inhibitors, chemokine receptor antagonists and integrase inhibitors (Table 1). The modes of action of the different classes of ARVs are:

- NRTI nucleoside analogues are triphosphorylated within the target cell prior to acting on the reverse transcriptase (RT), and some undergo further modification e.g. didanosine is converted to its active moiety 2',3'- dideoxyadenosine-5'-triphosphate. They function by inhibition of synthesis of DNA by RT, the viral enzyme that copies viral RNA into DNA of a newly infected cell.
- NRTI nucleotide analogues require only two additional phosphorylations to become active inhibitors of the RT because they are already monophosphorylated and the mode of action is the same as for the NRTI nucleoside analogues.
- NNRTIs bind to the RT enzyme causing conformational changes in the enzyme structure, resulting in inhibition of the enzyme.
- PIs bind to the enzyme protease, preventing cleavage of the *gag* and *gag-pol* polyproteins, thereby halting release of mature virus particles.
- Fusion inhibitors bind to the HIV envelope protein gp-41 which is involved in viral entry and prevents entry into the target cell. By binding to gp-41, fusion inhibitors interfere with conformational changes of the envelope required for fusion with the target cell.
- Chemokine co-receptor antagonists bind to the co-receptors (either CCR5 or CXCR4) on the surface cell of the CD4+ T-cell preventing entry to the target cell. In contrast with other ARVs which act on the viral enzymes, chemokine co-receptors antagonists act on the proteins of the target cell.
- Integrase inhibitors bind to a viral enzyme integrase and interfere with incorporation of the reverse-transcribed HIV DNA into the chromosomes of the target cell.

Table 1.1. Antiretroviral drug classes.

Class	Name of drug
Nucleoside Reverse Transcriptors	Abacavir
	Emtricitabine
	Lamivudine
	Stavudine
	Zalcitabine
	Zidovudine
Nucleotide Reverse Transcriptors	Tenofovir
Non-nucleoside Reverse Transcriptors	Delarivine
	Efavirenz
	Nevirapine
Protease inhibitors	Amprenavir
	Atazanavir
	Indinavir
	Lopinavir
	Nelfinavir
	Ritonavir
	Saquinavir
Fusion Inhibitors	Efuvirtide
Chemokine Receptor Antagonists	Maraviroc
Integrase inhibitors	Raltegravir

The prognosis of patients with HIV infection has been greatly improved by HAART. Viral suppression depends, amongst other factors, on the pharmacokinetics of the medicines and on adherence to treatment. The latter is influenced by side-effects, pill-burden, availability of treatment and stigmatisation [12]. Any negative effect on the pharmacokinetics of ARVs, e.g. drug-drug interactions and herb-drug interactions, may affect the outcome of treatment, hence it is important to ensure that the pharmacokinetics of these medicines is not altered. Therefore, clinicians and pharmacists have to be aware of possible interactions in order to prevent negative effects of such interactions on HAART.

1.5.2 Traditional Medicines

The use of Traditional medicines (TMs) has been on the increase over the past few years. More recently, there has been a dramatic increase, as evidenced by the increased commercialisation and marketing of TM products. WHO defines TMs as those medicines used in the practice of traditional medicine [13]. The WHO definition of ‘traditional medicine’ is: “health practices, approaches, knowledge and beliefs incorporating plant, animal and mineral based medicines, spiritual therapies, manual techniques and exercises,

applied singularly or in combination, to treat, diagnose and prevent illnesses or maintain well being.” [14]. This definition is very broad because of the need to ensure that it includes all types of traditional medicine, practised in the world. WHO has established some definitions [15] for the terminology used in traditional medicine and these are:

- *Complementary/Alternative medicine (CAM)* – broad set of healthcare practices that are not part of, and not integrated into, the specific country’s dominant healthcare system. Medicines used in this context are often referred to as CAMs.
- *Herbal medicines* – herbs, herbal material, herbal preparations, and finished herbal products that contain, as active ingredients, parts of plants, or other plant materials or combinations of the above
- *Herbs* – crude plant material such as leaves, flowers, fruit, stems, wood, bark, roots, rhizomes, or other plant parts, which may be whole, fragmented or powdered.

In recent years, the use of TMs has increased dramatically, and the market for these medicines is estimated at \$60 billion worldwide [13]. Use of TMs varies from country to country, and is summarised below:

- In China, TMs (more appropriately known as traditional Chinese medicines or TCMs) have a separate pharmacopeia and comprise 30-50% of the total medicinal consumption.
- In Europe, North America and other developed region, over 50% of the population have used CAMs at least once.
- In Germany, 90% of the population have used a natural therapy at some point in their life.
- In the United Kingdom, annual spending on CAMs is \$230 million and these medicines and their properties and uses, have been incorporated as a subject in the curricula of some pharmacy degree programmes.
- In Ghana, Mali, Nigeria and Zambia, the first-line therapy for 60% of children with high fever caused by malaria is the use of herbal medicines at home.
- In the United States, 158 million of the adult populace have used a natural remedy at some stage in their life. Between 1995 and 2000, the number of doctors who had

undergone special training in alternate or natural remedy medicine had nearly doubled.

- In South Africa, 75% of people with HIV/AIDS, otherwise known as People Living with AIDS (PLWA), use TM/CAM.

One of the reasons for the increase in the use of TMs is the belief that these products are free from side-effects, compared to orthodox medicines, especially for the management/treatment of chronic diseases.

Recently, African countries have agreed to include these medicines in the mainstream healthcare system [16]. As a result of the lack of mainstream healthcare facilities, people frequently visit traditional healers instead. WHO reported that 25% of modern medicines are made from plants which were first used traditionally [13]. Published clinical research on TMs is currently very limited. Despite the lack of scientific evidence of efficacy, quality and safety, the use of TMs to meet primary healthcare needs is high in Africa and also in Latin America where it is; estimated at 80% of the population [13].

There are many factors that influence the use of TMs/CAMs, and research on the use of TMs is increasing. In a study conducted in Ghana, it was found that culture, religion, finance and economics, education, advice of family members and introduction of Western systems (educational, medical and cultural) have all influenced the choice of healthcare system used [17]. Based on the findings from this study, the authors concluded that both traditional and modern medicines play a fundamental part of Ghanaian culture and that there is a need to integrate the two in order to provide a comprehensive healthcare system which best serves the interest of the population. In Mozambique, a study of medicinal plants used in the treatment of common ailments, such as diarrhoea, malaria, respiratory complaints and sexually transmitted diseases, showed that 46 different plant species were used [18], indicating a wide use of plants, medicinally.

In South Africa, the use of TMs is widespread [19] and one of the reasons for the use of TM is low medical doctor-to-patient ratio, which is estimated at 50: 50000, while that of traditional doctors is 50: 400; thus patients have far greater access to traditional doctors. Other reasons include economic, cultural and social. In the Eastern Cape region of South Africa, which has a population of 6.3 million (15% of South African population), it has been

reported that TMs are used to enhance personal well-being, as well as to treat diseases [20]. This region has a large low-socio-economic-standing population in several rural areas, and this suggests that the majority of this population use traditional methods of healthcare [21]. The traditional healthcare industry in South Africa is estimated at R500 million per annum [22], and in the Eastern Cape, a large proportion of the population relies to some extent on the generation of income from such natural resources [23]. Use of TMs in this region has increased by 54% with *Hypoxis hemerocallidea* (African Potato) being the most popular plant [24], due in part to the increase of HIV/AIDS prevalence. South Africa also plays an important role in the increase of research on TMs [25].

Assessment of quality of TMs is one of the critical initial steps that must be undertaken before assessing safety and efficacy. Information derived from plant/product quality will, to some extent, provide information about the safety and efficacy of the product. In China, a pharmacopeia on TMs has been developed and has been used for many years. In Germany, there are monographs of CAMs used in that country [26]. Development of monographs for TMs/CAMs is more challenging than that for orthodox medicines because TMs/CAMs usually contain more than one constituent, resulting in a highly complex multi-component matrix. The quality of some South African plant products and their constituents have been established and published in the literature [27, 28], and the work done by Nair *et al* [27] is considered important since commercialisation of TMs and associated products is rapidly increasing, and this work has shed valuable information on the quality of commercially available African Potato products.

Research on TMs conducted in South Africa includes both *in vitro* and *in vivo* studies. These studies have evaluated efficacy, safety and/or quality [29]. Recognition of the need to integrate TMs into the mainstream healthcare system began in the early 1990s, following the democratic election of a new government in South Africa (i.e., the post-apartheid era). During this recent period, researchers have evaluated the healthcare situation, (both past and current systems) and have proposed different models for integration [30]. These and other proposals culminated in workshops and communication between healthcare practitioners and traditional healers. The South African government had already taken steps to include traditional healers into the mainstream healthcare system before the heads of state of the Southern African Development Community (SADC) signed and ratified the SADC Protocol

on Health [31]. Cooperation between traditional healers and healthcare professionals has resulted in traditional healers providing HIV/AIDS education, as well as demonstrations of condom use [32].

1.5.2.1 *Policies Regarding TMs*

A WHO TMs Strategy [33] outlines the need for member states to integrate TMs into mainstream healthcare systems. The focus areas of this strategy are policy, safety, efficacy, quality, access and rational use. Governments are urged to:

- Devise national policy and regulation for the proper use of TMs and their assimilation into national healthcare systems.
- Institute regulatory mechanisms to control the safety and quality of TM products and of TM practice.
- Create understanding about safe and effective TM therapies among the public and consumers.
- Cultivate and conserve medicinal plants to guarantee their sustainable use.

An office has been established at the WHO headquarters in Geneva, Switzerland, to coordinate activities related to TMs with collaborating TM centres around the world, which are dedicated to the various TM strategies. The Geneva office, in consultation with member states, has produced a number of documents to assist these member states in achieving the objectives of the main strategy.

Research on plant material to treat HIV/AIDS has increased [34]. However, none of the plant substances or even semi-synthetic plant-derived molecules have yet been formally approved by regulators for marketing. In recent years, TMs have been discussed at the World Health Assembly and resolutions have been reached which will help member states of the WHO to meet the objectives of the main strategy [35]. In addition, the Joint United Nations programme on HIV/AIDS (UNAIDS) has been involved in activities to incorporate TMs into mainstream healthcare. In a meeting sponsored by UNAIDS, a task force was appointed for the East and Southern Africa regions whose objective was to build a research programme for safe and effective local treatments of HIV/AIDS [32]. Participants of this meeting included traditional healers, and most countries represented at that meeting reported some initiatives by their countries which involved traditional healers.

In the SADC region, a SADC Protocol on Health [36] is now used by member states to guide their health policies. In order to meet some of the objectives listed in this protocol, the member states have agreed to cooperate and assist one another with:

- Research and documentation on TMs and their use.
- The establishment of a regional databank of TMs, medicinal plants and procedures, in order to ensure their protection, consistent with regimens related to intellectual property rights governing genetic resources, plant varieties and plant technology.

This demonstrates the commitment of member states to TM use and increased research. Some SADC member states have also begun to regulate TMs, though not to the same extent as orthodox medicines, since the complexity of TMs amongst other reasons require a different system of regulation, amongst other reasons. Regarding TMs and HIV/AIDS, meetings have been held amongst SADC Ministers of Health during which the role of traditional and indigenous therapies has been discussed [37]. Attendants of one such meeting included, SADC ministry delegates, and ministers, delegates from United Nations Children's Fund (UNICEF) and UNAIDS, traditional healers, alternative/complimentary therapists and affected individuals (PLWA).

1.6 HIV/AIDS and TMs

1.6.1 Background

Use of TMs/CAMs among people PLWA is high as with all chronic disorders [11, 32, 38, 39]. The reasons for high usage are wide ranging and differ between developed and developing countries. They include cultural, economic, and social factors, as well as perceived efficacy and perceived safety. Until recently, ARVs were not readily available to most patients who needed them, especially those living in rural areas. These patients, therefore, tended to use TMs/CAMs to manage symptoms. Cost of ARVs was identified as one of the barriers to accessing such life-saving medicines and provision of free ARVs to patients in resource-poor settings was found to be associated with a significant probability of viral suppression [40]. A WHO 3 by 5 initiative, which is aimed at ensuring that 3 million people who needed ARVs should be on HAART by 2005, was initiated in 2003 to increase access to HAART [41]. As a result of this initiative and commitments by governments and

non-governmental organisation (NGOs), there are now significantly more people on HAART in Africa (Figure 1.4). Reduction in prices of ARVs [42] as a result of the World Trade Organisation agreement on Trade-Related Aspects of Intellectual Property rights (TRIPS) has also increased accessibility of HAART to PLWA in developing countries, especially in sub-Saharan Africa.

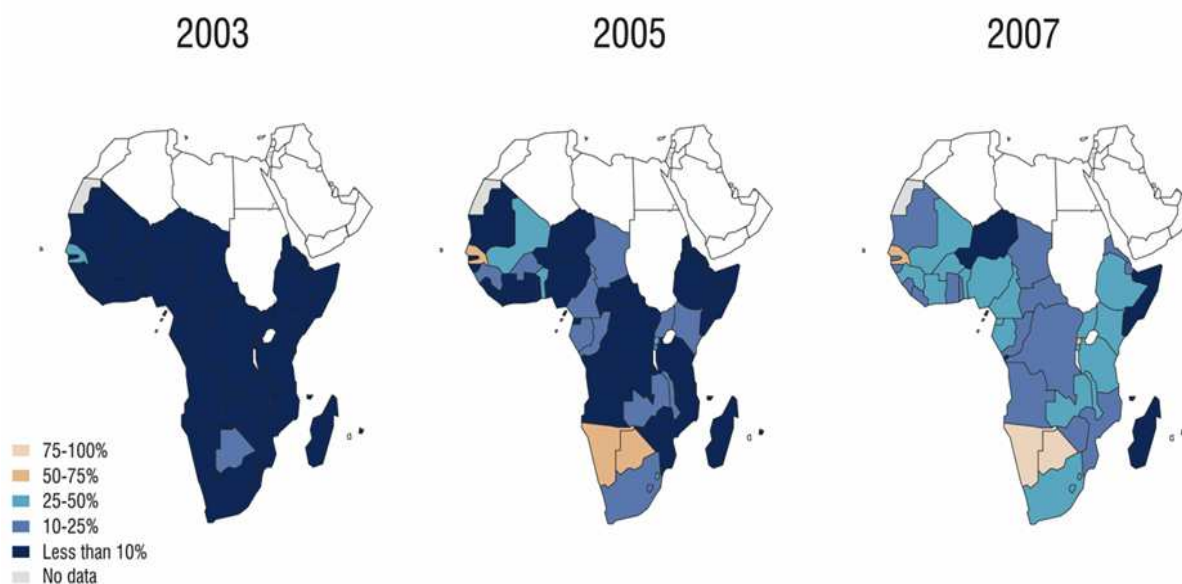

Figure 1.4. Trend of availability of ARVs in sub-Saharan Africa [2].

Despite improved access to, and ample evidence of the efficacy of HAART, there are still PLWA who prefer TMs [43, 44]. Some patients stop ART and use TMs because of severe side-effects, among other reasons [45]. This situation has been further fuelled by reports in all media about powerful immunostimulant properties being claimed for some TMs which give false hope to PLWA. These reports also present TMs as devoid of side-effects making them more attractive to PLWA. The use of TMs may affect adherence to HAART which is critical to suppression of viral replication. The perceived lack of side-effects of TMs is worsened by irresponsible marketing methods of these products by the product owners, who provide naive members of the public with erroneous and misleading information. Furthermore, this marketing occurs with little or no intervention by the medicines regulatory authorities, since regulation of TMs/CAMs is weak, if not absent in most countries [46].

Among PLWA on HAART, there are some who combine this treatment with TMs [38, 47, 48]. A multi-centre study conducted in Botswana, Lesotho, South Africa and Swaziland

involving 683 volunteers identified healthcare strategies used by PLWA to manage HIV/AIDS symptoms [11]. Volunteers were given a structured questionnaire and asked to describe three to six symptoms that they had experienced and also provide information about their management of the symptoms. Most of the patients reported orthodox medicines as their preferred choice followed by TMs/CAMs. The use of TMs and ARVs simultaneously can lead to interactions [49], hence there is an urgent need to conduct drug-TM interaction studies. Information regarding such interactions must be available to patients so that they are made aware of the quality, safety and efficacy of the medicines they are taking. In the case of orthodox medicines, this information is given to patients in the form of a Patient Information Leaflet. In the case of TMs, this information is very limited and is usually unavailable, hence therapy may be critically compromised by a lack of information. This has been confirmed in a Canadian study which demonstrated how HIV/AIDS patients were unable to access safety and knowledge of drug interactions related to CAMs [50].

There are many substances which are derived from plant materials which have been claimed to possess some antiretroviral activities. These products have been purported to inhibit HIV replication in nearly all stages of the virus life-cycle [34]. Substances were extracted by various solvents prior to assessing their activity against replication. Pre-clinical and clinical research on the activity of plant material against viral replication is on-going, and some *in vitro* studies are summarised Table 1.2.

Table 1.2. Antiretroviral properties of some plant extracts.

Name of plant	Part of plant	Substance extracted	Enzyme inhibited	Reference
<i>Sutherlandia frutescens</i>	flowers	None stated	RT	[51]
	leaves	None stated	RT	
<i>Lobostemon trigonus</i>	flowers	None stated	RT	
<i>Eucalyptus globoidea</i>	buds	Globoidnan A	Integrase	[52]
<i>Rosa rugosa</i>	roots	Rosamultin	Protease	[53]
<i>Peltophorum africanum</i>	roots	No extraction	RT and integrase	[54]

1.6.2 Safety of TMs

Users of TMs tend not to report any side-effects they may experience from these medicines, since such associations are considered not probable in view of their long historical use. Most of these patients do not disclose to the healthcare providers their use of a TM unless specific questions regarding these are asked. This makes data collection on TMs more challenging, compared to orthodox medicines. One of the hindrances of communication about TMs is that they are not yet integrated into the main healthcare system and have been shunned upon in the past, hence users tend to be secretive about their use [55]. Research on the safety of the products has increased in the past years, and in recognition of the lack of guidelines on research on TMs, WHO Western Pacific region, has published Research Guidelines for Evaluating the Safety and Efficacy of Herbal Medicines [56]. These guidelines assist researchers to cover all aspects of the product, including related species when evaluating safety and efficacy of TMs.

Unstructured regulation of TM/CAMs across the world also makes it difficult for safety profiles to be established [57]. Pharmacovigilance does not exist for TMs products in many countries [58], and this is because of lack of, or weak legislation. Various ways of establishing the safety of TMs which includes traditional use, chemical data, undertaking pharmacological and toxicological studies, intervention trials, epidemiological studies, patient case records and post-marketing surveillance have been reported [57]. It is important to note that data from post-marketing surveillance can be obtained only if the product is registered and as previously mentioned, most countries do not issue marketing authorisation for TMs so information from this source is limited. Some information on the safety of TMs, which are widely used in developed countries, however, is available in the literature.

In a review of potential health risks and medicinal interactions, Magee [59] listed uses, side-effects and potential drug interactions between a number of TMs and orthodox medicines. From this review, it can be seen that there are some known side-effects and adverse reactions of TMs. A pattern of fatal cases from TMs were reported by Stewart *et al* [60] who showed that 43% of poisoning cases were associated with plant materials, and within this category, 62% of these were used as a traditional remedy.

1.7 Drug-TM Interactions

Drug-TM interactions occur when a TM and an orthodox medicine influence the effects of each other. This may cause a change in pharmacodynamic and/or pharmacokinetic parameters which may affect efficacy or safety of either the orthodox medicine or the TM. Efficacy may be reduced or increased and adverse events may increase. One of the challenges with TMs is that they often contain more than one active ingredient which makes it difficult to assess or predict a specific interaction. Whereas drug interactions are usually studied during the initial development phase of orthodox medicines, this is not usually done in the case of TMs because there is generally no development phase similar to that of orthodox medicines except, perhaps, that of development pharmaceuticals if a pharmaceutical dosage form is required. Therefore, little information is available on drug-TM interactions.

1.7.1 Pharmacodynamic Interactions

A pharmacodynamic interaction occurs when a drug affects the pharmacodynamic response of another drug. These types of interactions generally either increase or decrease the actual response to the drug treatment. Pharmacodynamic interactions between ARVs and TMs have not been as well studied as pharmacokinetic interactions [61].

1.7.2 Pharmacokinetic Interactions

Pharmacokinetic interactions occur when a drug or TM affects absorption, distribution, metabolism or excretion of another drug or TM. These types of interactions are difficult to predict but can be evaluated using *in vitro* and/or *in vivo* studies. The most extensively studied interactions are metabolic interactions involving the cytochrome P₄₅₀ enzyme system and absorption interactions involving the transporter protein p-glycoprotein (P-gp). The results from *in vitro* studies give an indication of which enzymes or transporter proteins will be affected by the TM or orthodox medicine.

Data from *in vitro* studies can serve as a possible predictor of drug interactions. The prediction of drug interactions has been a topic of discussion among scientists for many years and proposals to improve existing methods have been suggested [62]. Unfortunately, the

prediction of drug interactions from *in vitro* studies may not always give an accurate measure of the clinical significance of an interaction [63, 64]. Hence, it must be emphasized that whereas *in vitro* data can be particularly valuable in developing strategies to study *in vivo* drug interactions, confirmation of the absence or presence of drug interactions should be by appropriate *in vivo* investigations. Clinical studies thus still remain the most important source of information on the effects of drug-TM interactions [65] on bioavailability. Some studies on drug-TM interactions are listed in Table 1.3.

1.7.2.1 Cytochrome P_{450} Enzyme System

The cytochrome P_{450} (CYP₄₅₀) enzyme system is a superfamily of haemoproteins that transform endogenous and exogenous substances in some living organisms e.g. bacteria, fungi, plants and animals. The name P_{450} comes from the fact that these enzymes have a spectroscopic absorption peak at or near 450 nm when bound, and reduced by carbon monoxide. In humans, CYP₄₅₀ enzymes are involved in metabolism of exogenous substances including medicines, alcohols, organic solvents, chemicals and environmental pollutants. Endogenous physiological compounds such as bile acids, steroids and fatty acids undergo some oxidative, peroxidative and reductive metabolism through the CYP₄₅₀ enzymes [66]. These enzymes are divided into families and subfamilies, CYP₄₅₀ proteins from all sources having more than 40% in amino acids are placed in the same family and are designated an Arabic numeral. Each subfamily consists of enzymes in which the amino acid sequence is more than 55% homology, and this is identified by a capital letter. Individual enzymes are denoted by an Arabic numeral, and the corresponding gene which expresses the individual enzyme is denoted by the same number in italics. In humans, 14 families and 20 subfamilies have been reported. Genetic polymorphism of some of these enzymes exists resulting in two groups of metabolisers, namely: poor or slow metabolisers, and extensive or rapid metabolisers. The slow metabolisers possess a homozygous autosomal recessive allele, while the other group possess heterozygous or homozygous dominant allele.

Table 1.3. Clinical studies of interactions between TMs/CAMs and orthodox medicines and effects on bioavailability.

Name of TM/CAM	Interacting drug	Sample size	Study Design	Results	Adverse effects	Reference
St. Johns Wort (<i>Hypericum perforatum</i>)	Norethindrone and ethinyl estradiol	16 healthy female volunteers	Non-randomised single-blind, sequential	AUC ↓13-15% Cl/F ↓25%	Breakthrough bleeding during the St. Johns Wort phase	[67]
	Nevirapine	5 (HIV positive men, control 176 used population pharmacokinetics)	Case study	Clearance ↓35%	none	[68]
	Imatinib mesylate	10 healthy volunteers (7 male)	Open-label, complete cross-over, fixed sequence	AUC ↓32% C _{max} ↓29%	none	[69]
	Quazepam	13 healthy male volunteers	Randomised, double-blind, cross-over	AUC ↓55 ng h ml ⁻¹ C _{max} ↓8.7 ng/ml	none	[70]
	Tacrolimus	10 healthy volunteers (8 male and 2 female)	Two-phase, cross-over	AUC ↓34%	none	[71]
	Theophylline	12 healthy volunteers	Randomised, open-labelled, cross-over	No significant difference	none	[72]
Milk Thistle (<i>Silybum marianum</i>)	Indinavir	16 (8 in each group, 2 from the control group excluded)	Randomised parallel	AUC ↑ 21.9%	mild	[73]
	Indinavir	10	Open label	AUC ↓ 9%, trough concentrations ↓ 25%	mild	[74]
	Indinavir	10 (7 men)	Sequential crossover	Not conclusive because sample size was small, study was not powered for bioequivalence	none	[75]
Garlic	Saquinavir	9 healthy volunteers	Two-treatment, 3 period, single sequence, longitudinal	AUC ↓ 51% C _{max} ↓ 54%	none	[76]

Metabolism of endogenous and exogenous compounds involves biotransformation into hydrophilic or polar compounds to enhance elimination. Biotransformation reactions are classified into phase 1 and 2 reactions. Phase 1 reactions include oxidation, reduction and hydrolysis, while Phase 2 reactions links either a parent drug or a product of phase 1 metabolism to an endogenous substrate. Reactions of phase 2 biotransformation include acetylation, conjugation with amino acids, glucuronidation, glutathione conjugation, methylation and sulphation. Orthodox medicines, including TMs may be substrates of more than one enzyme. Studies have shown that these enzymes are widely distributed in the body but concentrated in the liver. CYP 3A4 is found in the mucosa of the small intestine and other enzymes are present in the duodenum [77]. Some CYP₄₅₀ enzymes are found in the brain and adipose tissue.

Interactions involving CYP₄₅₀ enzymes generally are of two types: induction or inhibition. Inhibition reduces metabolism, while induction increases metabolism. Usually, substrates of CYP₄₅₀ enzymes are potential inhibitors of those enzymes but there are cases where an inhibitor may not be a substrate of the inhibited enzyme. Inhibition is an immediate phenomenon that becomes evident as soon as the inhibitor comes into contact with the enzyme. The extent of inhibition depends on the concentration of the inhibitor at the site of the enzyme relative to the intrinsic potency of the inhibitor [78].

There are two categories of inhibition: direct and irreversible. Direct inhibition can occur in a competitive, non-competitive, uncompetitive or mixed (competitive and non-competitive) manner, and the process usually begins with the first dose of the inhibitor. Irreversible inhibition involves metabolism-dependant inhibition where metabolism of another drug is completely blocked. A rare interaction which is a variation of the irreversible inhibition is called metabolism dependent “reversible” inhibition. In this case a drug is metabolised and the metabolite is a more potent inhibitor than the parent drug [78].

Induction of the CYP enzymes requires prior exposure to a chemical inducer of the hepatocyte’s CYP-synthesis mechanism. This results in up-regulation of the production of one or more CYP enzymes. Unlike inhibition, induction has a slow onset and consequently a slow recovery to baseline when the inducer is removed. The magnitude of induction depends on both the concentration of the inducer and on the duration of the exposure [78].

1.7.2.2 P-glycoprotein

P-gp is a transport protein which was initially implicated in multi-drug resistance in neoplastic tissues of Chinese hamster cells [79]. It is encoded by the multi-drug resistance-1 (*MDR1*) gene. P-gp is a dimer comprising of 1280 amino acids with 2 adenosine 5'-triphosphate (ATP) binding domains and is classified as a member of the ATP-binding cassette superfamily of transport proteins. These transporters are known as ATP-binding cassette (ABC) transporters. P-gp has a wide range of substrates both structurally and pharmacologically. In general, the substrates are large molecules and are lipophilic and cationic at physiological pH. P-gp transports drugs across from epithelial cells into the intestinal lumen (Figure 1.5), and is located on the apical membrane of these cells; therefore, it can affect absorption of drugs. Any change in the expression of the *MDR1* gene which would affect the activity of P-gp may alter the pharmacokinetics of P-gp substrates.

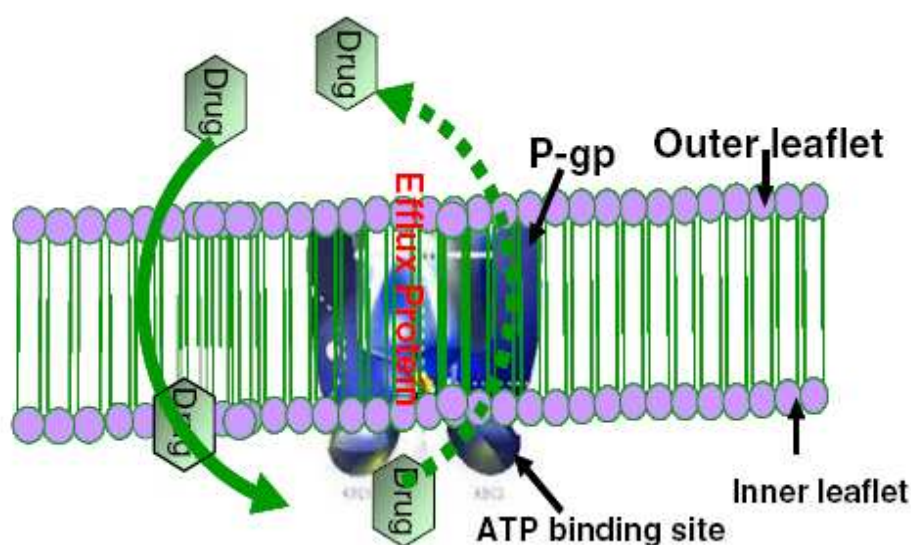

Figure 1.5. Diagrammatic representation of p-glycoprotein-mediated drug efflux [80].

P-gp is involved in drug absorption as well as in drug disposition. This transporter is also found in the liver where it transports substrates from hepatocytes into the canalicular space, kidney, leucocytes and the blood brain barrier. The role of P-gp in the kidney is to eliminate xenobiotics from the blood into the urine and to some extent, limit re-absorption of these substrates into tubular cells.

It has been reported that P-gp shares some substrates and inhibitors with CYP3A4, and have been found to have common tissue distribution [81]. Substances which are substrates of both P-gp and CYP3A4 may be absorbed into the epithelial cells, metabolised in the cells and also be excreted into the intestinal lumen [82], creating a cyclic effect. Therefore, transporter affinity of a drug or TM needs to be considered in conjunction with the impact of metabolising enzymes such as CYP₄₅₀ isoenzymes [83].

Induction of P-gp has also been studied in cell lines, animals and humans. Rifampicin is a potent inducer of P-gp activity. In a study on healthy human volunteers, orally-administered rifampicin reduced the C_{max} and AUC of digoxin, but there was no effect on intravenous administration [84]. Duodenal biopsies revealed that rifampicin increased intestinal P-gp content 3.5 fold. Some TM/CAM extracts have been found to modulate P-gp activity which could lead to drug-TM interactions (Table 1.4).

Table 1.4. Interactions of TM/CAM and orthodox medicines involving P-gp.

Name of Herb	Interacting Drug	Study design	Sample size	Results	Reference
Milk Thistle (<i>Silybum marianium</i>)	Digoxin	Randomised, open-label, four-way cross-over	16 healthy volunteers (8 female)	No significant change in AUC and C _{max}	[85]
Black Cohosh	Digoxin			No significant change in AUC and C _{max}	
St. Johns Wort	cyclosporine	-	1 organ transplant patient	Rejection of transplant	[86]

1.7.3 In vitro Studies: Effect of *Hypoxis hemerocallidea* on the CYP Enzymes and the Protein Transporter P-glycoprotein

Assessment of the inhibition of CYP3A4, 3A5 and CYP19 by AP extracts, hypoxoside, rooperol, AP formulations and other compounds was done by Nair [87]. The AP was dried by different methods and prepared in the same manner (boiled in water). The results showed very high inhibition of CYP3A4 and 3A5 at greater than 98% inhibition by rooperol. Inhibition by hypoxoside was less than half that of rooperol while inhibition by AP extracts (traditionally prepared) was about 21.0, 40.0 and 45.0 for CYP3A4, 3A5 and CYP19, respectively. These were very important findings, since most people use AP sold by traditional healers.

Effects of the same samples mentioned above on P-gp were examined using ritonavir as the positive control. The method used to investigate the functional activity of P-gp in CaCo-2 cells was based on measuring rhodamine 123 (Rh123) retention/efflux in the presence of P-gp modulators. The Rh123 is a cationic fluorescent dye taken up by cells and actively pumped out of the cells by P-gp. In the presence of P-gp inhibitors, the ability of CaCo-2 cells to efflux Rh123, is decreased resulting in intracellular accumulation of Rh123. Results of this assay showed induction rather than inhibition by the AP extracts, hypoxoside and rooperol [88]. The highest induction was seen with hypoxoside even though it had a minimal effect on the inhibition of CYP enzymes. As mentioned previously, *in vitro* data can provide useful information to alert researchers to the possibility that drug interactions may occur when various medicines are used concurrently. *In vitro* data, therefore, serve as a signal that drug interactions may occur but it is again re-emphasized that such *in vitro* results must be confirmed by carrying out appropriate *in vivo* investigations.

CHAPTER 2

EFAVIRENZ AS AN ANTIRETROVIRAL AGENT

2 EFAVIRENZ

2.1 Introduction

Efavirenz (EFV) is an HIV-1 reverse transcriptase inhibitor (NNRTI) approved in many countries for use in combination with other antiretrovirals for the treatment of HIV-1 infection. In the WHO Anatomic and Therapeutic Classification (ATC), EFV is classified as a systemic antiretroviral, and has been coded J05A G03. The scientific name of EFV is (4S)-6-chloro-4-(cyclopropylethynyl)-1,4-dihydro-4-(trifluoromethyl)-2H-3,1-benzoxazin-2-one. Synonyms of EFV are: 5B706; DMP-266; Efavirentsi; Efavirenzum; L-743 and L743726. The molecular formula of EFV is $C_{14}H_9ClF_3NO_2$, and its molecular weight is 315.7. EFV structure is shown in Figure 2.1.

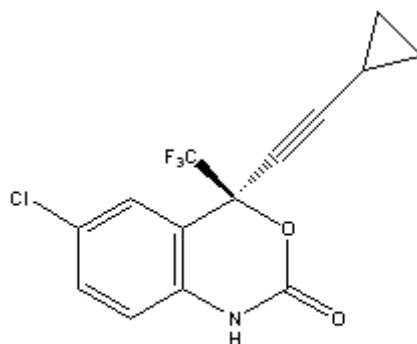

Efavirenz

Figure 2.1. Chemical structure of EFV.

2.2 Synthesis

EFV was discovered by Merck Research Laboratories company, West Pont, PA, USA, which provided the first report on its reverse transcriptase inhibitor properties in 1995 [89].

2.3 Purity

Sources of EFV impurities are generally solvents and intermediate products from the route of synthesis. The International Pharmacopeia [90] lists the possible impurities, and states that

the purity of EFV should be within 97% to 103% of $C_{14}H_9ClF_3NO_2$ calculated with reference to the dried substance

2.4 Physicochemical Properties of EFV

2.4.1 Solubility

EFV is practically insoluble in water but soluble in methanol. It is a non-hygroscopic lipophilic material. The aqueous solubility of EFV is $9.2 \mu\text{g/ml}$ (pH 8.7) at 25°C , and it increases as the pH increases above pH 9 [91]. The increase in solubility at higher pH is because of the loss of the proton on the amine of the carbamate moiety.

2.4.2 Ultraviolet (UV) Absorption

The UV spectrum of a solution of EFV exhibits one maximum absorption at $\lambda=247 \text{ nm}$ [90]. A UV spectrum of EFV in acetonitrile: 0.1 M formic acid: methanol (52:43:5 %v/v) is shown in Figure 2.2.

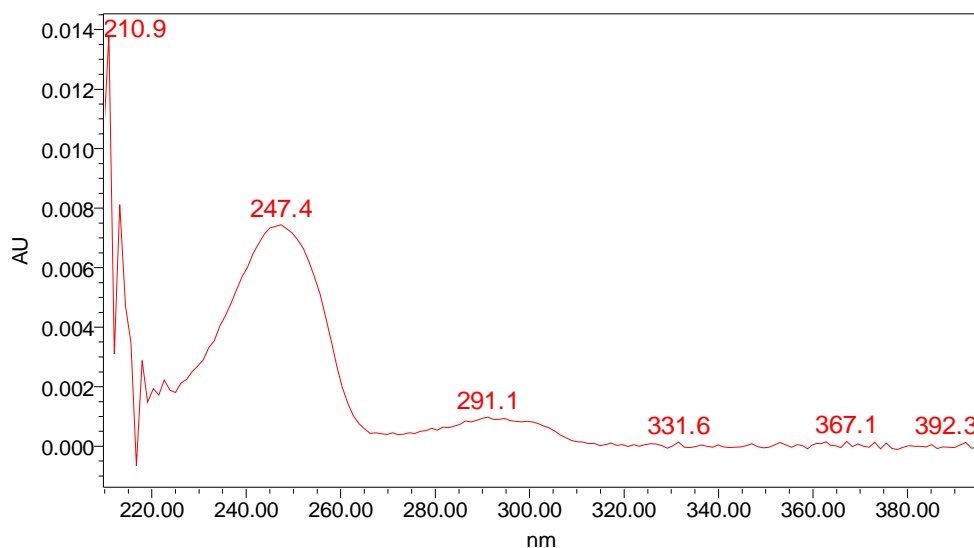

Figure 2.2. UV spectrum of EFV.

2.4.3 Description

It is a white to slightly pink powder [90].

2.4.4 Melting Point and pKa

The melting point of EFV is 137 ± 1.4 °C, and its pKa is 10.2 at 25°C. At 60 °C, the pKa of EFV was determined from non-linear regression analysis as 9.1 [91], and this is consistent with the effect on increased temperature on the ionisation of the proton donor.

2.4.5 Polymorphism

EFV exhibits polymorphism and there are four polymorphs, I, II, III and IV, which have been identified [92]. In another patent three polymorphs were identified [93]. The three polymorphs of EFV were identified using both Differential Scanning Calorimetry (DSC) and X-ray Diffraction. Form III is the most stable of the forms and is used to make compressed tablets.

2.4.6 Stereochemistry

Stereoisomerism exists when a molecule or chemical entity has at least one asymmetric carbon, known as a chiral centre. EFV has two enantiomers, the *R* (inactive) and *S* (active) enantiomers [89]. The *R* enantiomer has no activity on the reverse transcriptase enzyme.

2.5 Stability

The aqueous stability of EFV was evaluated as a function of pH and buffer species by Maurin *et al* [91]. The following buffers were used: acetate, borate, citrate, hydrochloric acid, phosphate, sodium hydroxide and the pH range from 1.0 to 12.8. The solution stability was assessed at a temperature of 60 °C. Degradation of EFV was rapid at a pH range 9.2 to 12.8 and it followed first-order kinetics. The carbamate hydrolysis pathway has been proposed as the predominant reaction throughout the pH range studied. There may have been two kinetically indistinguishable mechanisms of hydrolysis (Figure 2.3). The two pathways are consistent with classical methods of carbamate hydrolysis.

reported that the NNBP is located at a distance of 10\AA (1 nm) from the polymerase substrate site on the HIV-1 RT [94]. The HIV-1 RT is a heterodimer, consisting of two polypeptides of sizes 66kDa and 51kDa, these are referred to as p66 and p51. These two polypeptides contain the same amino acids, although the p51 polypeptide does not appear to have any active sites. A recent study by Tacheddjian *et al* [95] found that EFV enhances formation of homodimers p66/p66 and p51/p51, as well as binding to p51. This might be one of the reasons why EFV is highly potent against HIV-1 RT.

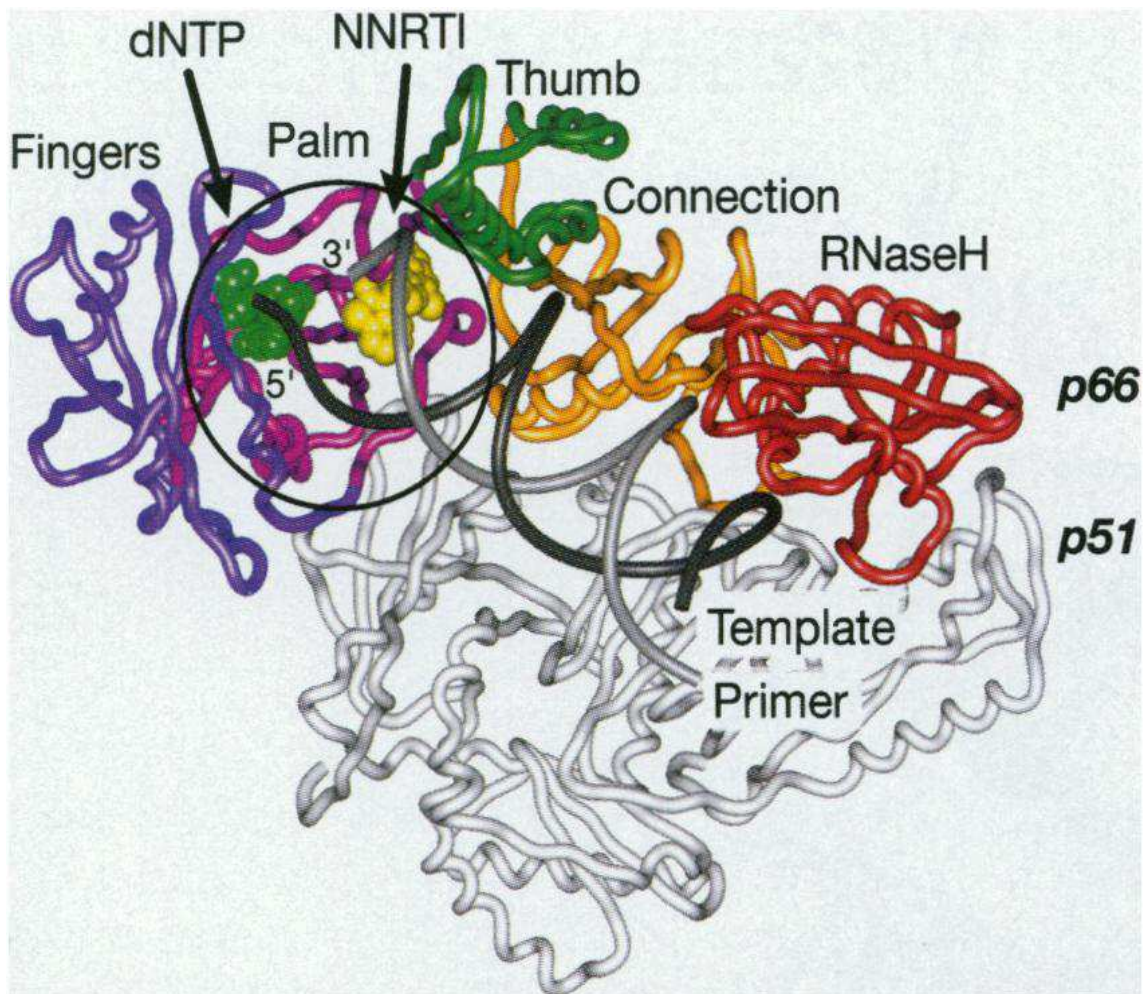

Figure 2.4. Diagram of the HIV-1 RT heterodimer in the complex with an NNRTI [96].

Two domains of the HIV-1 RT are DNA polymerase and ribonuclease H (RNaseH). These domains are located in the p66 polypeptide. Four subdomains on each of the polypeptides exist, and are denoted as “fingers, thumb, palm and connection”, see Figure 2.4. The subdomains consist of different amino acid residues: finger (1-85 and 118-155), palm (86-117 and 156-237), thumb (238-318) and connection (319-426) [94]. There is a large cleft

formed in the p66 which accommodates the template/primer substrate, in this case an NNRTI. These amino acid residues can be hydrophobic or hydrophilic in nature, but most are hydrophobic such as those on the NNBP. On binding to the NNBP, the NNRTI interacts with the amino acid residues to form hydrogen bonds, and π - π interactions are also involved (Try181, Tyr188, Phe 227, Trp 229 and Tyr 318 have aromatic side chains). The amino acid residues mould the inner cleft such that the NNBP is almost closed. Flexibility is needed in order for NNRTIs to bind to the NNBP, and this has been confirmed by Ragno *et al* [97] in cross-docking of RT and NNRTI complexes studies.

NNRTIs have at least one aromatic ring which is capable of participating in π - π interactions with the amino acid residues. They also have groups which are capable of donating and/or accepting electrons to form hydrogen bonds, e.g. NH-C=O or NH-C=S, and are hydrocarbon rich, hence bind well at the hydrophobic NNBP. Once bound to the NNBP, NNRTIs induce conformational changes to the orientation of the amino acid side-chains. This directly affects the global hinge-bending mechanism that controls p66 fingers and thumbs subdomains. Conformational changes do not directly affect the mobility of each subdomain. The NNRTI binding thus slows down the rate of reaction, which is catalysed by HIV-1 RT (rate limiting step), hence replication of HIV is greatly reduced.

Studies have shown that NNRTIs bind to NNBP without affecting polymerase site, thus inhibiting the HIV-1RT uncompetitively. This was confirmed by simultaneous binding of the natural deoxynucleic triphosphate (dNTP) to the polymerase site, and NNRTI binding to the NNBP on the HIV-1 RT [98]. Therefore, NNRTIs are currently used in combination with NRTIs. At the molecular level, it has been shown that NNRTIs inhibit the removal of nucleoside analogues from the DNA terminus by HIV-1 RT, which is mediated by physiological concentrations of ATP [99]. EFV was found to be the most potent NNRTI, even on the mutations of K103N, Y181C and K103N/Y181C.

Interactions of EFV and NNBP are strongest at the Lys101 [100] with interaction energy of -11.29 kcal/mol (the overall energy was -22.75 kcal/mol). Thus, the strongest interaction was with Lys101. Binding energy of EFV was lower than that of Nevirapine (NVP), which could be the other reason for EFV being more potent than NVP. Binding energy is a measure of

flexibility of the molecules. Studies on deformation energy have shown that flexibility is an important aspect of effective binding to NNBP.

EFV is not active against human DNA polymerases α , β and γ , *Escherichia coli* RNA polymerase and HIV-2 RT polymerase with IC_{50} (50% inhibitory concentration) $>300 \mu\text{M}$ [89]. It is highly effective against the wild-type HIV-1 RT virus with IC_{50} K_i (inhibitory constant) greater than 2.93 nM.

2.7 Mutations at the NNBP

The RT has an inherent high replication error rate, which is estimated at about 10^{-4} replications. Like other RNA-dependent polymerases, RT lacks proofreading mechanisms, hence the high error rate. The life-cycle of HIV can be completed in 24 hr (up to 10^{10} - 10^{11}). These mutations can occur prior to administration of ARVs or during administration of ARVs. Mutations occur on the amino acid residues on the NNBP such that the binding of the inhibitors is affected.

Major mutations at NNBP are K103N, V106A, V179D, Y181C, A98G, K101E, V108I, G190AIS, P225H, M3230L and E138K. These mutations affect the conformation of NNBP, hence reducing the strength of binding of the inhibitors to the site. The most common mutation which is resistant to EFV is K103N. Low level resistance of EFV has been associated with P225H and Y181C. Compared to older NNRTIs, EFV is less affected by mutations at the NNBP. This could be because EFV forms strong hydrogen bonds with the Lys101 residue in the palm, and is more flexible than older NNRTIs [101, 102].

2.7.1 Types of Mutations

Mutations can involve base substitution or base frame shift of the amino acid residues in or near the NNBP. These substitutions are initiated by the template-primer slippage because they occur at the 3' or 5' end of the protein. Single substitution of one amino acid is the most common mutation, e.g., K103N. There are mutations where two or more amino acid molecules are substituted, but the frequencies of these are fewer [103].

2.7.2 Factors Affecting Mutations

EFV has a long plasma half-life such that when the treatment regimen dosing is interrupted (either by treatment holiday or poor adherence), the virus is exposed to single therapy of EFV which can result in mutations. Patients with CYP2B6 516TT genotype are more prone to mutations if triple therapy is stopped simultaneously, because then, EFV plasma half-life is prolonged in these patients [104, 105]. The presence of high level of mutations which are resistant to drugs have been found to increase the rate of mutations of the wild-type viruses [103]. Poor adherence results in varying plasma concentrations of drugs, and consequently, increased mutations [106].

2.8 Hyper-susceptibility to EFV

Hyper-susceptibility is defined as exhibition of significant increase in susceptibility of the virus to ARVs. In some cases where patients were previously treated with NRTIs and were NNRTI-naïve, it was found that 34% were hyper-susceptible to EFV [107]. Replication assays revealed that the hyper-susceptibility was associated with H208Y/T215Y and V118I/H208Y/T215Y mutations. These are double and triple mutations. There was no hyper-susceptibility for the single mutations.

2.9 Pharmacokinetics of EFV

The pharmacokinetics of EFV has been studied in rats, monkeys [108] and humans [109]. In rats and monkeys, EFV exhibited nonlinear pharmacokinetics within the relatively high range of dosing used, which was aggravated by delayed gastric-emptying in these species and saturable metabolic processes [108]. In humans, the delay in gastric emptying is not significant because the dosing is once daily, hence the amount of drug in the body remains within the linear range.

2.9.1 Absorption

EFV is well absorbed after the oral administration to humans. Only less than 1% of an oral dose is excreted in urine and faeces. Peak plasma concentrations are reached within 5 hr of

dosing and the drug's pharmacokinetics is linear with plasma concentrations increasing with increasing dose.

2.9.2 Effect on P-glycoprotein

The effect of EFV on P-gp activity has been assessed on different cells and yielded different results. In canine kidney cell lines, EFV was found to inhibit multi-drug resistance proteins [110], while it was found to induce P-gp in peripheral blood mononuclear cells isolated from healthy volunteers [111]. In an *in vitro* study on Caco-2 cells undertaken by Störmer *et al* [112], EFV was found to be a weak inducer of P-gp, and, therefore, less likely to affect drug efflux. The effect of EFV on P-gp activity on immortalised rat brain cell line has been found not to be significant, and EFV uptake through the blood-brain barrier of adult male Wistar rats was not affected by P-gp inhibitors [113]. In another study by Berruet *et al* [114], EFV was found not to be an inducer or inhibitor in rats. Mouly *et al* [115] assessed the effect of EFV on intestinal P-gp, and found that the effect of EFV on P-gp was not detectable, hence no clear conclusion was reached. Thus, the effect of EFV on P-gp is still not well established.

2.9.3 Distribution

Lipophilicity of EFV renders it highly distributed in the body. EFV has been found in various sites and cells in the body such as the microglia, semen, lymphocytes and peripheral blood mono-nuclear cells. In a population pharmacokinetic meta-analysis involving 334 healthy human volunteers from phase 1 clinical studies, the apparent volume of distribution (Vd/F) after a single and multiple doses were 151 L and 190 L, respectively [116]. In another population pharmacokinetic study involving 235 HIV positive patients from a cohort of patients on EFV based regimens, Vd/F was found to be $252 \pm 14\%$ [117]. From these two studies, it can be concluded that EFV is widely distributed in the body. Almond *et al* [118] found that the ratio of intracellular EFV AUC₀₋₂₄ to unbound EFV AUC₀₋₂₄ was over 200, which showed that there is more unbound EFV in the intracellular spaces than in plasma. In a study where 11 patients on EFV were assessed for penetration of EFV into the CSF, EFV was not detectable but this method does not state the lower limit of quantitation (LLOQ), of the LC/MS method [119]. EFV has a high affinity for adipose tissues in humans [120] due to its lipophilicity.

2.9.4 Metabolism and Elimination

EFV is a substrate of the cytochrome P₄₅₀ (CYP₄₅₀) enzyme family, in particular CYP2B6 and CYP3A4. Metabolism of EFV has been studied in cynomolgous monkeys, guinea-pigs, hamsters, humans and rats, and EFV was found to be extensively metabolised in all these species [109]. There are some differences and similarities in the metabolism between species. In humans, metabolites were mainly found in urine, while plasma samples showed mostly unchanged EFV. Seven metabolites were found in human urine (Figure 2.5) [109], and six were found in plasma. Oxidative hydroxylation at three positions in the EFV molecule is the main mechanism of metabolism. These metabolites then undergo phase II conjugation, and this is where there are significant differences between species. In humans the preferential route is conjugation with glucuronic acid at C8, whereas in rats, it was sulphuric acid. The main metabolites are the glucuronide conjugates of 8-hydroxyefavirenz and 7-hydroxyefavirenz after multiple dosing, while the N-glucuronide conjugate of EFV was the major metabolite after single dosing. The structures of these metabolites were confirmed by mass spectroscopy (MS) and nuclear magnetic resonance (NMR).

In one *in vitro* study using human liver microsomes (HLMs), CYP2B6 was determined as the main enzyme involved in the metabolism of EFV [121]. Primary metabolites of EFV were found to be 8-hydroxyefavirenz (main) and 7-hydroxyefavirenz (minor), and 8,14-dihydroxyefavirenz (secondary) in the *in vitro* study. The formation of 8,14-dihydroxyefavirenz showed a longer lag-time relative to formation of 8-hydroxyefavirenz. It was confirmed that the formation of 8,14-dihydroxyefavirenz followed a step-wise hydroxylation of EFV, with 8-hydroxyefavirenz as an intermediate. Metabolites of EFV were evaluated for antiretroviral activity, and it was found that none of them exhibited any antiretroviral activity [122].

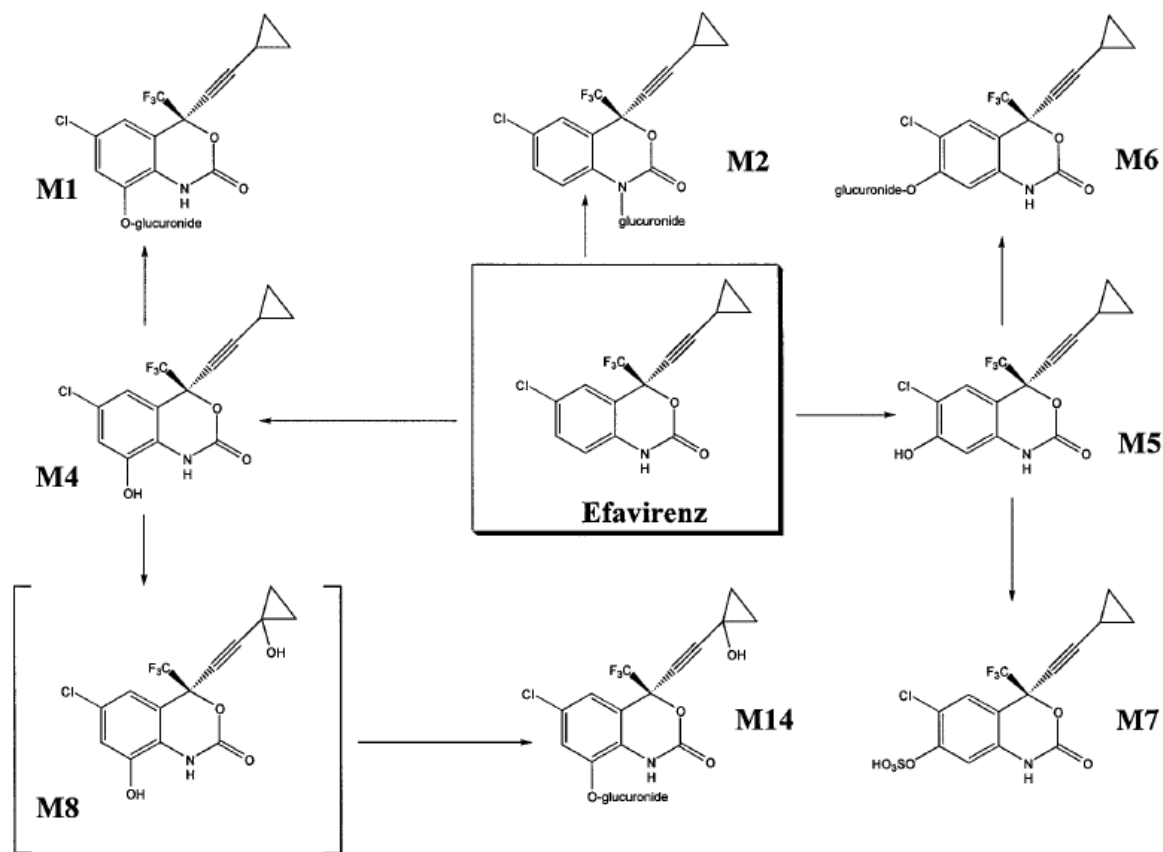

Figure 2.5. Proposed metabolic pathway for EFV in humans [109].

The clearance of EFV is higher in Caucasians than in Blacks and Asians [123]. This phenomenon can be caused by variability in the gene expressing CYP2B6. Prevalence of homozygous *CYP2B6* */*6 allele among West Africans and African-Americans were found to be higher than Caucasians, Asians and Hispanics [124]. Stähle *et al* [125] found high intra- and inter-patient variability in plasma EFV concentrations, with inter patient variability reaching 84%. It was suggested that the high variability could be caused by polymorphism exhibited by *CYP2B6*. Patients with the homozygous *CYP2B6* */*6 allele have been found to have higher plasma concentrations than those with heterozygous *6, or those without the *6 allele [126, 127]. Patients with the homozygous recessive allele are at higher risk of developing adverse events from high EFV plasma concentrations. There is thus a higher probability that patients with the homozygous *CYP2B6* */*6 allele will experience more prolonged EFV plasma exposure following discontinuation of therapy [104]. This could lead to the undesirable situation of EFV monotherapy on discontinuation of the ARV regimen.

Therefore, it is important that patients do not discontinue therapy or take holidays from therapy unless a proper plan has been made by clinicians.

The elimination half-life of EFV after single and multiple oral doses is 55-76 hr and 40-55 hr, respectively, the latter being because EFV induces its own metabolism. EFV can induce or inhibit CYP3A4, thereby affecting plasma concentrations of CYP3A4 substrates [115]. Conjugated oxidative metabolites are excreted in bile and in urine [109]. Only less than 1% is excreted unchanged in urine and faeces.

2.10 Drug Interactions of EFV

2.10.1 EFV as a Substrate of CYP3A4

Since EFV is a substrate of CYP3A4 and CYP2B6, inhibitors and inducers of these enzyme systems may affect EFV plasma levels. The following drugs and herbs/plants/TMs have been shown to affect metabolism of EFV, however the mechanisms of inhibition or induction were not stated:

- Rifampicin increases metabolism of EFV, resulting in a reduction in AUC (22%), and C_{\min} (25%) in healthy individuals. The recommendation is that the dose of EFV may be increased to 800 mg daily in patients on rifampicin except for low body weight patients [128].
- Carbamazepine increases metabolism of EFV, resulting in a reduction in AUC, C_{\max} and C_{\min} , with mean ratios and 90% CI being 0.64 (0.60-0.68), 0.79 (0.74-0.85) and 0.53 (0.47-0.59), respectively. The mean ratios and the 90% CI of these parameters were outside the 0.8 to 1.25 bioequivalence limits [129].
- Voriconazole increased the steady-state mean AUC_{0-24} and C_{\max} of efavirenz by 43% and 37%, respectively [130].
- Nevirapine decreases EFV AUC (22%), C_{\max} (17%) and C_{\min} (36%) on co-administration. Due to higher risk of side effects and no improvement in efficacy over either NNRTI alone, this combination is not recommended [131].
- St. Johns Wort can induce metabolism of EFV by induction of metabolising enzymes and/or transporter proteins which could lead to reduced plasma levels of EFV. This induction effect may persist for at least 2 weeks after cessation of treatment with St. Johns Wort [132].

2.10.2 Induction of CYP3A4

EFV induces CYP3A4, and has been associated with clinically significant drug interactions (Table 2.1). Using the Erythromycin Breath Test (ERMT), hepatic CYP 3A4 activity was significantly increased by EFV compared to placebo in healthy human volunteers [115]. Induction occurred on day 11 of dosing with 200 mg EFV, and on day 4 after dosing with 400 mg EFV. Dissipation of induction occurred 21 days after the last dose of 400 mg EFV, and this is due to the long half-life of EFV. Induction of CYP3A4 was found to be both time- and dose-dependent. EFV's induction is less than that of rifampicin which induces CYP3A4 by 125% compared to 55% of EFV.

Table 2.1. Pharmacokinetic interactions of EFV resulting from induction of CYP450 enzymes.

Drug	Pharmacokinetic Parameters	Isoenzyme Induced and mechanism	Clinical Significance	Recommendation	Reference
Buprenorphine	AUC ↓50%	CYP3A4 N-dealkylation	Yes	Close monitoring, dose alteration	[133]
Methadone	AUC ↓52% C _{max} ↓45%	CYP3A4 NS*	Yes	Close monitoring, dose alteration	[134]
Rifabutin	AUC ↓38% C _{max} ↓32% C _{min} ↓45%	CYP3A4 Oxidation	Yes	Close monitoring, dose alteration	[135]
Carbamazepine	AUC ↓27% C _{max} ↓20% C _{min} ↓35%	CYP3A4 NS	Yes	Carbamazepine plasma levels should be monitored, if necessary alternative anticonvulsants should be used	[129]
Bupropion	AUC ↓55% C _{max} ↓34% AUC of active metabolite unchanged	CYP2B6 Hydroxylation	Possibly	Close monitoring, dose alteration if necessary	[136, 137]
Ketoconazole	AUC ↓72% C _{max} ↓44% Cl _{tot} ↑201%	CYP3A4 Oxidation	Yes	Alternative treatment to considered	[138]
Voriconazole	AUC ↓55% C _{max} ↓36%	NS	Yes	Dose of voriconazole should be adjusted	[139]
	AUC ↓80% C _{max} ↓66%	NS		Co-administration contraindicated	[130]
Simvastatin	AUC ↓58%	NS	Yes	Monitor cholesterol levels and adjust dose if necessary	[140]
Atorvastatin	AUC ↓34%	NS			
Pravastatin	AUC ↓40%	NS			

*NS- not stated

Clinical studies have been conducted to assess the effect of EFV on the pharmacokinetics of different drugs metabolised via CYP3A4 and 2B6 isoenzymes. Interactions between EFV and some Protease Inhibitors (PIs) e.g., indinavir, lopinavir, azatanavir, have been confirmed in clinical studies, and results showed reduction in plasma levels of the PIs. These interactions have to be monitored clinically to avoid adverse events.

2.10.3 Inhibition of CYP3A4

EFV competitively inhibits CYP3A4 isoenzyme activity which results in clinically significant interactions. This competitive inhibition could result in increased plasma concentrations of the interacting drugs. Co-administration of EFV with astemizole and cisapride are contraindicated because of the possibility of occurrence of life-threatening cardiac arrhythmias, however the mechanism of inhibition was not reported [132].

2.11 Efficacy

A study conducted on HIV positive patients in South Africa revealed that EFV, in combination with didanosine and lamivudine, reduced plasma viral load and increased mean T cell count within 10 days of commencing therapy [141]. Undetectable viral levels were reached by some patients and the time to reach undetectable levels in those patients who had low (<150 cells/ μ l) cell count was significantly lower. In treatment-naïve patients, reduction of viral load up to 2.4 log₁₀ copies/ml has been observed on EFV-based triple regimen [142]. This reduction was evident as early as 3 months post-initiation of treatment. After 9 months of treatment, the highest increase of T cells was observed. Patients in an AIDS Clinical Trials Group (ACTG) A5095 study which was randomised, double blinded and placebo controlled, were assessed for virological and immunological response following a three or four ARV treatment regimen [143]. Treatments involved 3NRTIs; 2NRTIs and EFV; 3NRTIs and EFV. The 3NRTIs treatment arm was discontinued early, due to inferior results. Viral suppression was achieved from week 16 through 3 years on the EFV-based treatment arm, as well as in the other two arms.

The efficacy of EFV was compared to that of nevirapine as a secondary objective in a single centre, observational, prospective, comparative cohort study among 100 study participants

who were treatment naïve [144]. After 48 weeks of treatment, 79% of patients on the EFV arm had achieved viral suppression, compared to 74% NVP. Thus, there were no significant differences between the two NNRTIs.

2.12 Clinical Uses

Clinically, EFV is effective against HIV replication and positive results were assessed both by virological and immunological responses [145-147]. Surrogate markers for efficacy of EFV used in some of these studies are lack of, or delayed development of, AIDS defining illnesses. In treatment-naïve patients, the rate of viral suppression can also be used as a measure of efficacy. There are no data to show efficacy of EFV alone, because clinical studies would be inappropriate and unethical, since ARVs should not be given as single therapy. This is due to failure of treatment of single therapy; hence efficacy of EFV has been shown in combination with other ARVs.

2.13 Side-effects

Dermatological and neuropsychiatric side-effects are the main adverse events following treatment with EFV. Rare but potentially serious skin rashes have been reported during use of EFV, including Stevenson-Johnson syndrome. The most common (greater than 10%) but not life-threatening are psychiatric symptoms (dizziness, depression, insomnia, anxiety), pain and skin rashes are very common with a median onset of 8 days [148]; increase in High Density Lipids (HDL) and total cholesterol; diarrhoea and nausea. It has been reported that the psychiatric symptoms resolved after changing therapy from EFV to nevirapine in a retrospective analysis study [149]. Less common side-effects are headache, impairment of concentration, somnolence, abnormal dreams, fatigue, severe depression, hallucinations, nervousness, pruritis, vomiting, dyspepsia, abdominal pain and anorexia. These symptoms can persist even after three months of therapy [150]. In one patient who took an overdose of EFV, the CNS symptoms subsided when EFV treatment was stopped [151]. In a study conducted on Japanese patients who were on EFV-based HAART, it was found that the most common side-effect was abnormal dreams, and one of the patients reported loss of libido [152].

CHAPTER 3

AFRICAN POTATO (*Hypoxis hemerocallidea*): DRUG INTERACTIONS

3 AFRICAN POTATO

3.1 Geographical Distribution

Hypoxis is a genus of the hypoxidaceae family which is widely distributed around the world, with reports of existence in various countries including America [153, 154], New Zealand [155], South Africa [156], Malawi [157], Madagascar, Mauritius [158], Mozambique [159], Zimbabwe and other Central Africa countries [160].

3.2 Taxonomy

There has been various efforts undertaken by botanists to describe species of *Hypoxis*, and the more recent revision is reported by Singh [156]. In this taxonomic revision, 30 species of *Hypoxis* in Africa are reported, and of these, 21 are endemic to southern Africa. This diverse genus lacks distinct diagnostic characteristics which have been reported to be difficult in describing the species taxonomically. However, the nomenclature presently is based on leaf characters, leaf venation, floral characters, inflorescence and their use [156]. Singh [156] reduced this large number of species to nine synonymic names for the species where most of the species are grouped under one of names are shown below:

- *Hypoxis angustifolia* var *buchananii*
- *Hypoxis argenta* var *sericea*
- *Hypoxis colchicifolia*
- *Hypoxis floccosa*
- *Hypoxis hemerocallidea*
- *Hypoxis longifolia*
- *Hypoxis obtusa*
- *Hypoxis ridigula*
- *Hypoxis ridigula* var *pilosissima*

The most abundant species in the Eastern Cape region of South Africa is *Hypoxis hemerocallidea*. It was first described by Fisch, C. A. Mey and Ave´-Lall in 1842 as *Hypoxis rooperi*, and has now been included as a synonym for *Hypoxis hemerocallidea* by the taxonomists. These plants exhibit some variations in leaf dimensions, numbers of bright yellow flowers, and dimensions of pedicels. Young plants have 2 flowers on long or short pedicels, while in older plants, the number of flowers varies from 4 to 12, with variable length of firm pedicels (Figure 3.1).



Figure 3.1. Photograph of a young *Hypoxis hemerocallidea* plant [161].

The plant has an underground bulb called a “corm”, and this corm is vital to the resistance of the plant to cold winters. The corm is brown in colour, and has adventitious roots. When cut open, the inside of the corm is bright yellow, and turns dark-brown within a few minutes. The sizes of the corm vary according to the age of the plant, one-year-old corms can weigh up to 200 g, and the older ones are even larger (800 g). Due to the resemblance of the corm to a

potato, this plant has also become commonly known as “African Potato”. It is also called the African “yellow” star flower, because of its bright yellow flowers.

3.3 Uses

Ethanobotany suggests that *Hypoxis* plants, especially their corms are used by traditional healers in Africa for years. Some of the uses reported in literature have been listed in Table 3.1. Both the corms and the leaves of *Hypoxis hemerocallidea* have been used for the treatment of various diseases.

Table 3.1. Traditional uses of *Hypoxis hemerocallidea*.

Reported Use	Part of plant	Preparation	Area	Reference
Diabetes	Corms	Fresh corms, boiled and taken orally	Eastern Cape, South Africa	[162]
Prostate hypertrophy	NS*	NS*	Maputo, Mozambique	[18]
Urinary or venereal diseases	NS*	NS*	KwaZulu Natal, South Africa	[163]
Cancer	Corms	Pulverised corms are boiled and taken orally	Eastern Cape, Southern Africa	[164]
Wound management	Leaves corms	Dry powder sprinkled on wounds Fresh or dried material extracted and used as wash	Eastern Cape, South Africa	[165]
HIV/AIDS management	NS*	NS*	Johannesburg, South Africa	[47]

*NS – not stated

3.4 Chemical Constituents

The main compounds reported are known as norlignans with a Ph-C5-Ph or Ph-C3 (C2)-Ph skeleton [159]. It has been suggested that these norlignans are derived from cinnamic acid and cinnamyl alcohol and linked β - γ' and α - β' . The chemical structures of norlignans are based on the linkage positions between two units [166]. The linkages in the compounds from the hypoxidaceae species are C7-C8' linkages. It is not surprising to find similar constituents of *hypoxis* genus in other hypoxidaceae like *Curculigo recurvata* in Italy [167].

Reports on isolation of compounds from *Hypoxis* dates back to 1982 when Marini-Bettolo *et al* [159] extracted the corm of *Hypoxis obtusa* from Mozambique using methanol. An uncommon structure which they named hypoxoside was found to be the major constituent of the corm, with yields of 3.7%. In 1983, Drewes *et al* [168] extracted hypoxoside from *Hypoxis rooperi* and other species, including *H. accuminata*, *H. nitida*, *H. obtusa*, *H. rigidula* and *H. latifolia*. Yields of 3.5 and 4.5% hypoxoside were reported in extracts from *H. hemerocallidea*. The concentration of hypoxoside is reported to vary from corm to corm.

3.4.1 Hypoxoside

3.4.1.1 Chemical Name

The chemical name of hypoxoside is (e)-1,5-bis-(4'- β -D-glucopyranosyloxy-3'-hydroxyphenyl)-pent-4-en-1-yne.

3.4.1.2 Structure

The structure of hypoxoside (Figure 3.2) was confirmed by Marini-Bettolo *et al* 1981; 1985; Drewes 1984, Nair 2007, and Laporta 2007 [27, 168-170] by spectroscopic methods.

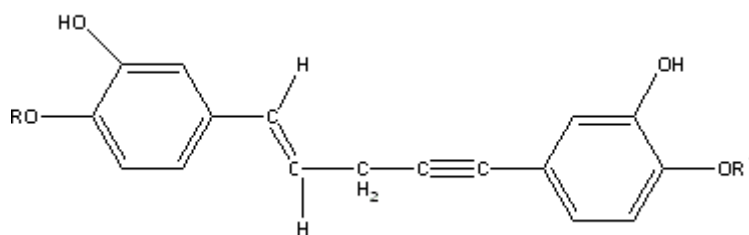

	Hypoxoside	Obtuside A	Obtuside B
R	β -D-glucose	β -D-glucose	H
R¹	β -D-glucose	H	β -D-glucose

Figure 3.2. Structures of hypoxoside, obtuside A and obtuside B.

3.4.1.3 Physicochemical Properties

The melting point of hypoxoside is 149-151°C, and it is very soluble in both methanol and water [169]. When dissolved in methanol, it exhibits three maxima in UV spectra at 212, 258 and 298 nm.

3.4.2 Obtuside A and B

Obtuside A and B (Figure 3.2) were isolated from *H. obtusa* by Marini-Bettolo *et al* in 1982 [169], at the same time when they isolated hypoxoside.

3.4.3 Nyasoside

Nyasoside, (Figure 3.3) was extracted from *Hypoxis nyasica* plant collected from Malawi using methanol, and yielded 3.0%, which was less than the yield of hypoxoside (5.0%) from the same plant [171]. Like hypoxoside, nyasoside is a di-glucoside which on hydrolysis with β -glucosidase yielded D-glucose and an oily aglucone called nyasol.

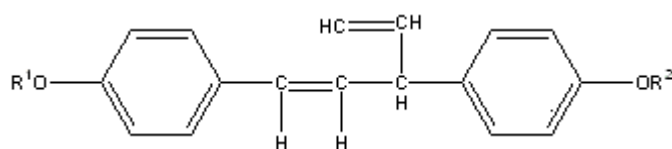

	nyasoside	nyasol	nyaside	mononyasine A	mononyasine B
R ¹	β -D-glucose	H	β -D-glucose	H	β -D-glucose
R ²	β -D-glucose	H	Ap▶6-Glucose	β -D-glucose	H

Figure 3.3. Chemical structure of nyasoside, nyaside, nyasol, mononyasine A and mononyasine B.

3.4.4 Nyaside

This compound was isolated at the same time as nyasoside [171] (Figure 3.3).

3.4.5 Mononyasine A and B

Mononyasine is a glucoside which was first identified by Messana *et al* [172] after extraction from *Hypoxis nyasica*. The plant was collected from Malawi and a sample was kept in the University of La Sapienza Botanical Gardens. Two of these glucosides were found in the extract, and the structure was elucidated by electron impact mass spectrum. The two compounds were named mononyasine A and mononyasine B (Figure 3.3). These two structures were solved by ^{13}C nuclear magnetic resonance (NMR) spectroscopy. On hydrolysis with β -glucosidase, both compounds yielded glucose and an oily aglucone called nyasol.

3.4.6 Obtusaside

Obtusaside is a phenolic glycoside (Figure 3.4) which was extracted using methanol from *Hypoxis obtusa* by Msonthi *et al* [157]. The plant was collected from Malawi and identified as *Hypoxis obtusa*. The structure was elucidated by both ^1H and ^{13}C NMR. Enzymatic hydrolysis with β -glucosidase yielded a 2,5-dihydroxybenzyl alcohol.

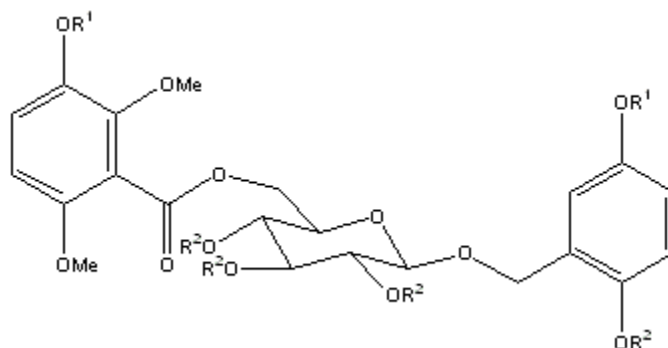

where, R¹ and R² are hydrogen atoms

Figure 3.4. Chemical structure of Obtusaside.

3.4.7 Nyasol

Nyasol (Figure 3.4) was isolated and identified by Mass and NMR spectroscopic methods by Sibanda *et al* [173]. This compound, along with hypoxoside, nyasoside, nyaside, mononyasine A and mononyaside B, was extracted by methanol from a plant harvested in Zimbabwe. The plant was identified as *Hypoxis angustifolia*.

3.4.8 Sterols and Sterolins

Some sterols and sterolins have been identified, and in some cases, quantified in the extracts of *Hypoxis*. In 1975, a patent was registered with the British patents office, on the extraction of sterols and sterolins from plant material, in particular *Hypoxis* [174]. These were identified as β -sitosterol and β -sitosterol glucoside. Four years later, another patent was registered by Pegel *et al* [175] in America, on methods of extraction of these sterols and sterolins from *Hypoxis* plants. In both cases, the amount of sterols and sterolins recovered were claimed to be high, while another study reported far much lower amounts [176].

3.5 Pharmacological Activity of AP

3.5.1 Immunomodulation Properties

Bouic *et al* [177] reported on *in vitro* effects of β -sitosterol (BSS) and β -sitosterol glucoside (BSSG) on human peripheral lymphocyte proliferation. Lymphocyte proliferative responses are believed to have restorative properties in the immune system, as demonstrated in studies conducted by Salen *et al* [178]. For the *in vitro* proliferative assay, both the mononuclear cells and T-cells were used. Enhanced proliferation was seen on T-cells which had BSS and BSSG only, and not on the mononuclear cells. It was concluded that these results showed that BSS and BSSG are capable of enhancing T-cell proliferative responses.

3.5.2 Antioxidant Activity

The antioxidant activity of *Hypoxis rooperi* extract and its main compounds, hypoxoside and the metabolite of hypoxoside, rooperol, were assessed by Laporta *et al* [170]. Both hypoxoside and rooperol showed antioxidant activities which increased with increasing concentrations of the compounds. However it is reported that rooperol exhibited higher antioxidant activity than hypoxoside [170].

Free radical scavenging activity using, 1,1-diphenyl-2-picryl hydroxyl (DPPH) assay, of aqueous AP extract, hypoxoside and rooperol, were evaluated by Nair *et al* [87]. Aqueous extracts of AP showed high levels of activity that increased with increasing concentration. Rooperol showed high free radical scavenging activity compared to the reference compound;

quercetin, but hypoxoside did not exhibit similar activity. In the same study, the antioxidant activity was assessed using Ferric Reducing Activity Plasma (FRAP), and rooperol exhibited high antioxidant activity, while hypoxoside did not exhibit any activity. It was suggested that the slight antioxidant activity of AP aqueous extract could be due to other compounds, and not to hypoxoside. Methanolic and aqueous extracts of *Hypoxis hemerocallidea* were found to possess free radical scavenging activity which was comparable to that of vitamin C, which was the control [179]. This study assessed antioxidant properties, using free radical scavenging method, while the former employed FRAP, lipid peroxidation assay, superoxide anion oxidation assay, as well as free radical scavenging method. Therefore, the antioxidant property report by Nair *et al* [87] provides a comprehensive assessment of potential antioxidant activity, since each test provides a different insight on potential antioxidant activity.

3.5.3 Anti-inflammatory Properties

It is reported that hypoxoside and *Hypoxis rooperi* did not inhibit activity of COX-1 and COX-2 enzymes *in vitro*, but rooperol noticeably inhibited both these enzymes [180]. Methanolic extracts of *Hypoxis hemerocallidea* were assessed for prostaglandin-synthesis inhibition, and found to inhibit synthesis of prostaglandins. In 2006, Steenkamp *et al* [179] assessed the anti-inflammatory activity of *Hypoxis* extracts, and indomethacin was used as a control and reported that ethanolic extracts exhibited higher inhibitory effects than aqueous extracts.

In experimental models of rat oedema, aqueous *Hypoxis* extract was evaluated for anti-inflammatory activity and compared to diclofenac [181]. The model was rat hind paw oedema, which was induced by injection of intra-plantar injection of fresh egg albumin. This phlogistic agent resulted in acute inflammation of the paw, and an aqueous extract of *Hypoxis hemerocallidea* is reported to have produced significant reduction in inflammation [181].

3.5.4 Antinociceptive Properties

Thermal and chemical tests were used to assess antinociceptive properties of aqueous *Hypoxis hemerocallidea* extracts in mice [181]. The thermal pain was induced by placing the

mice in a beaker which was heated by a hot plate, and the pain stimulus (jumping out of beaker) was assessed. There was a significant increase in the time taken to respond to pain in mice dosed with extract compared to control group. However, this was less than the response from the morphine group. Based on this result, it is reported that the AP aqueous extract may have centrally- and peripherally-mediated analgesic properties [181]. Chemical pain was induced by intra-peritoneally administering 0.2 ml of 3% acetic acid solution to the mice. The mice were divided into three groups: control, AP aqueous extract, and diclofenac. AP aqueous extract significantly relieved pain more than the control, but was less than diclofenac. These investigations concluded that an AP aqueous extract exhibited analgesic properties.

3.5.5 Antidiabetic/Hypoglycaemic Effects

The hypoglycaemic effects of methanolic extracts of *Hypoxis hemerocallidea* were evaluated in male Wistar rats weighing 250-300 g [182]. The doses of AP extract were 100-800 mg/kg orally and were compared to placebo and standard treatments of glibenclamide (5 mg/kg) administered orally and insulin 5 μ U/kg subcutaneously. The AP extracts produced significant reduction in blood glucose concentration. In another study, Ojewole *et al* [181] compared the hypoglycaemic effects AP aqueous extracts to control and chlorpropamide (a first generation sulphonylurea). The AP aqueous extract was found to significantly reduce blood glucose levels. However, the mechanism of this hypoglycaemic effect is not reported.

3.5.6 Anticonvulsant Activity

Plant species traditionally used in the treatment of epilepsy and convulsions were selected and assessed for binding to GABA_A – benzodiazepine receptor complex. *Hypoxis hemerocallidea*, *Hypoxis angustifolia* and *Hypoxis colchicifolia* species were some of the species and extracts which were prepared with both ethanol and water [183]. All the hypoxis leaves and corms showed dose-dependent anti-convulsant activity.

3.5.7 Antibacterial Activity

One of the traditional uses of AP is the treatment of wounds where both leaves and the corm have been used [165]. The antibacterial properties of *Hypoxis hemerocallidea* leaves and

corm were assessed by Katerere *et al* [184] after extraction with acetone and methanol. The important nosocomial organisms tested were *Staphylococcus aureus*, *Pseudomonas aeruginosa*, *Escherichia coli* and *Enterococcus faecalis*. The dried corm extract was the most effective against *S. aureus*. The antibacterial activity of ethanolic and aqueous extracts of *Hypoxis hemerocallidea* against *Escherichia coli* were assessed and found to inhibit growth of the organism but this inhibition was reportedly less than the inhibition induced by ciprofloxacin [179].

Laporta *et al* [180] reported on antibacterial activity of *Hypoxis rooperi* extract, hypoxoside and rooperol against *Staphylococcus aureus* and *Escherichia coli*. The antibacterial effect observed was comparatively less than that of neomycin which was used as a reference. It was also reported that the gram-positive strain *S. aureus* was the most sensitive bacteria.

Inhibition of motility and multiplication of bacteria by agglutinins of lectins in some plants were assessed. Lectins are non-enzymatic proteins which bind to mono- and oligosaccharides reversibly with high selectivity. *Hypoxis hemerocallidea* reportedly produced some agglutinins which resulted in precipitation and inhibition of the growth of *S. aureus* and *Bacillus subtilis* [185].

3.6 Pharmacokinetics

The pharmacokinetics of hypoxoside and rooperol were studied in humans [186] and mammals (baboons) [187]. It is reported that there were differences in the profiles of the metabolites between species.

3.6.1 Absorption

It is reported that hypoxoside is not absorbed into the circulatory system, but is converted to its aglycone, rooperol (Figure 3.5) by β -glucosidase, due to enzymatic hydrolysis after oral administration [186]. The presence of biotransformation products were analysed in serum, faeces and urine of an adult male volunteer after administration with 1 g of hypoxoside. Analysis of faeces 6 hr post dosing showed the presence of rooperol, while after 24 hr, no rooperol was found in urine. Therefore, it was concluded that some of the rooperol was absorbed from the colon, and some was eliminated in the faeces. It was suggested that the

formation and absorption of rooperol were zero-order saturable processes [188]. The bioavailability of rooperol has not yet been established.

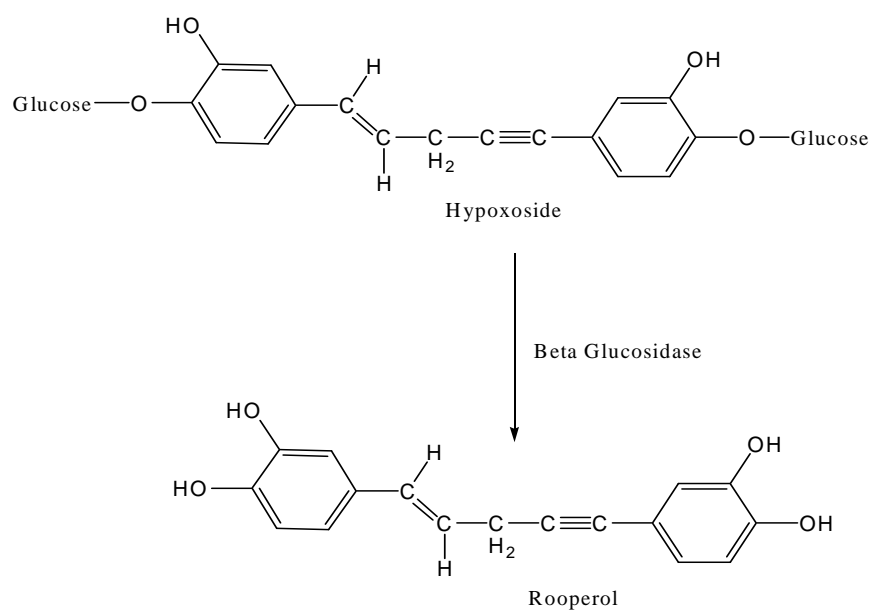

Figure 3.5. Metabolism of hypoxoside.

3.6.2 Metabolism and Elimination

Rooperol undergoes extensive first-pass metabolism such that no rooperol can be detected in the serum after administration of hypoxoside. Three metabolites of rooperol were isolated from serum samples of man after oral administration with hypoxoside [186]. These metabolites were rooperol-disulphate, rooperol-diglucuronide and rooperol monoglucuronide-monosulphate mixture, the latter being the major one [186]. Structures of these metabolites were confirmed after selective enzyme hydrolysis with arylsulfatase and/or β -glucuronidase. The end products of the hydrolysis were rooperol, dehydroxyrooperol and bis-dehydroxyrooperol. The metabolites have long half-lives, 50 hr for the major one, and 30 hr for the other two, respectively [188] and are eliminated in the urine whereas rooperol is eliminated via faeces.

3.7 Clinical Studies

Extracts of *Hypoxis hemerocallidea* have been used in various clinical studies to determine efficacy based on purported content of sterols and sterolins. Berges *et al* [189] conducted a randomised, placebo-controlled, double-blind clinical trial of β -sitosterol in patients with benign prostatic hyperplasia. The 200 patients with symptomatic benign prostatic hyperplasia received 20 mg β -sitosterol or placebo daily for six months. The assessment was based on modified Boyarsky scores, which were compared before and after treatment (primary outcome), and the secondary outcomes included urine volume, residual urine volume, and prostatic size. The authors report that after six months there was significant improvement of modified Boyarsky scores in the β -sitosterol-treated group. Residual urinary volume was decreased in the β -sitosterol group, compared to the placebo group. The mechanism of action of β -sitosterol in the treatment of BPH is, however, not yet known.

The effect of a plant sterol/sterolin mixture on cytokine secretion of cells from HIV-positive patients' peripheral blood was evaluated [190]. The study was conducted on three groups of volunteers, healthy donors, HIV-positive individuals not on ART, and HIV-positive individuals on a sterol/sterolin mixture (Moducare[®] which is claimed to contain 20 mg sterol and 0.2 mg sterolin). Volunteers were administered sterol/sterolin mixture dosage form for a period of six months. It is reported that this study showed that more INF- γ (which is produced by T cells) was expressed in patients who were treated with the sterol/sterolin mixture when compared to the other groups. Therefore, the authors concluded that these results could translate into a stabilisation of CD4+ T cell numbers *in vivo*, hence slow or no progression of the disease. The blinding of the study, was however, not reported, and statistical acceptance criterion for a clinically significant difference was not stated *a priori*.

An open-labelled study on HIV-infected patients was conducted over a six-year period [191]. This resulted in follow-up data from only 123 patients over a period of 39 months. Plasma viral loads and T cell counts were used as measures of efficacy. After 39 months, there was no significant change on T cells of patients whose cell at baseline was 200-500/ μ l. Patients whose T cell count was greater than 500/ μ l showed significant changes in viral load, but there was no significant change in the T cell count. It was concluded that this sterol/sterolin mixture could be beneficial for those individuals who are diagnosed shortly after infection.

3.8 Safety of *Hypoxis hemerocallidea*

A lethal dose (LD₅₀) in mice was found to be 1948 ± 57 mg/kg of aqueous AP extract after oral administration [181]. Assessment for signs of toxicity was continued for up to 48 hr, and log-dose response plots were constructed to determine the median lethal dose (LD₅₀). Lower doses (≤ 1600 mg/kg) of aqueous AP extracts were found to be safe, while relatively higher doses were toxic and/or lethal to the mice. In another study, mice were given 2000 mg/kg (45% hypoxoside) of standardised *hypoxis* extract and there was absence of toxicity on assessment two weeks post-dosing [170].

The safety of AP on neonatal rats was assessed by Erlwanger and Cooper [192]. Suckling rats of 10 days of age were divided into four groups, according to the randomisation schedule. The groups received high dose ethanol extracts, low dose ethanol extracts, high dose aqueous and low dose aqueous extracts. The visceral organs, proximal and distal half of the small intestine were examined microscopically for intestinal morphology. It was found that suckling rats on the low dose alcoholic extract had reduced weight of the pancreas, compared to the control, and the group on low dose aqueous extract. The reduction in pancreatic weight did not have an effect on the weight of the neonates, and similar phenomenon was not observed at high doses. Therefore, it was suggested that the reduction in pancreatic weight may not be of biological significance.

A phase I clinical trial was conducted involving 24 cancer patients at Karl Bremer Hospital, Bellville, South Africa [193], where the toxicity of hypoxoside, which was administered in the form of a *hypoxis* plant extract, was assessed. The patients were dosed with 1200 - 3200 mg standardised *hypoxis* plant extract (50-55% hypoxoside content) per day, in three divided doses. It was concluded that the biochemical and haematological tests revealed no obvious toxic effects from the administered hypoxoside.

3.9 *In vitro* Drug Interaction Studies

The effects of *Hypoxis hemerocallidea* on CYP3A4, pregnane X receptor (PXR) and P-gp were examined using a microsome-based *in-vitro* fluorometric microtitre assay. Inhibitory capacities of commercially-available preparations and aqueous extracts of hypoxis were examined. Significant inhibition of CYP3A4 by the hypoxis preparations and extract were

shown at an initial concentration of 100 mg/ml [194]. There was significant activation of PXR on exposure to *hypoxis*, while moderate activity was shown on the P-gp. These results identified potential for clinically significant interactions. Other *in vitro* drug interaction studies have previously been discussed in Chapter 1.

3.10 Registered Patents

Several patents concerning *Hypoxis rooperi*, hypoxoside and rooperol have been registered in the United States and Europe following studies on rooperol, hypoxoside, sterols and sterolins mixture, and their analogues in the treatment of HIV infection and other diseases [195, 196]. The patents include methods of extraction and preparation of derivatives [174,197]. A patent registered under the title “method of treating viral infections” was registered by Liebenberg [198], which relates to corms of the family of hypoxidaceae in preparation of medicament to treat viral infection by reducing the rate of decrease of T lymphocytes.

CHAPTER 4

HIGH PERFORMANCE LIQUID CHROMATOGRAPHY (HPLC) METHODS FOR AFRICAN POTATO AND EFAVIRENZ

4 INTRODUCTION

4.1 Background

High Performance Liquid Chromatography (HPLC) is used routinely in pharmaceutical analysis. Following injection of a sample onto an HPLC column packed with a stationary phase, the components in the mobile phase (MP) migrate through a chromatographic column at different rates, depending on their relative affinities for the two phases. Affinity for either mobile or stationary phase depends on various factors such as the adsorption, size and charge of the components amongst others [199]. Compared to gas chromatography, HPLC does not require compounds to be volatile, therefore, it can be used for a wide variety of compounds.

The extent of separation of compounds in HPLC is defined by resolution (R_s), and there are other parameters used to determine system functionality. These parameters include column efficiency (N), capacity factor (k), and tailing factor [200].

4.1.1 Resolution

Resolution can be varied by changing the chromatographic experimental conditions, and is influenced by selectivity, column efficiency and retention [201]. Resolution is a measure of separation between two adjacent peaks, and for adequate separation, the value of R_s should not be less than two [202]. The following equation is used to calculate resolution:

$$R_s = \left(\frac{\sqrt{N}}{4}\right) \left(\frac{\alpha-1}{\alpha}\right) \left(\frac{k'B}{1+k'B}\right) \quad \text{Equation 4.1}$$

4.1.2 Column Efficiency

Column efficiency is the ability of a column to produce sharp and narrow peaks with good resolution, and is measured in number of theoretical plates (N). This is based on the theory that assumes that the column is composed of a series of discrete theoretical plates, and that the migration of a solvent and solute is a stepwise transfer from each plate to the next. It is also assumed that at each plate, equilibrium of the sample occurs between the MP and the stationary phase. The efficiency of a chromatographic column is said to improve with the number of equilibrations, or increase in the number of plates. Therefore, the number of plates (N) is a measure of column efficiency. Another theory exists for the column plate number as a function of all experimental conditions where plate number is a function of plate height and column length (Equation 4.2). The height equivalent of a theoretical plate (H) varies with the velocity of the MP as it passes through the column.

$$N = \frac{L}{H} \quad \text{Equation 4.2}$$

where,

N = Number of theoretical plates

L = Length of column packing (cm)

H = Height equivalent of theoretical plates

The theory was limited in describing other effects on column efficiency, and it was, therefore, replaced by the kinetic or rate theory which is capable of accounting for these variables. Nevertheless, N and H are still used in description of column efficiency. Column efficiency can be defined in terms of peak asymmetry and retention time (Equation 4.3 and 4.4)

$$N = 16 \left(\frac{t_R}{W} \right)^2 \quad \text{Equation 4.3}$$

$$N = 5.54 \left(\frac{t_R}{W_{h/2}} \right) \quad \text{Equation 4.4}$$

where,

t_R = Retention time of solute

W = Width of peak at base

$W_{h/2}$ = Peak width at half-height

A good column has an efficiency of not less than 2000 [200]. Figure 4.1 shows chromatographic separation of two compounds and peak measurements used to calculate system functionality parameters.

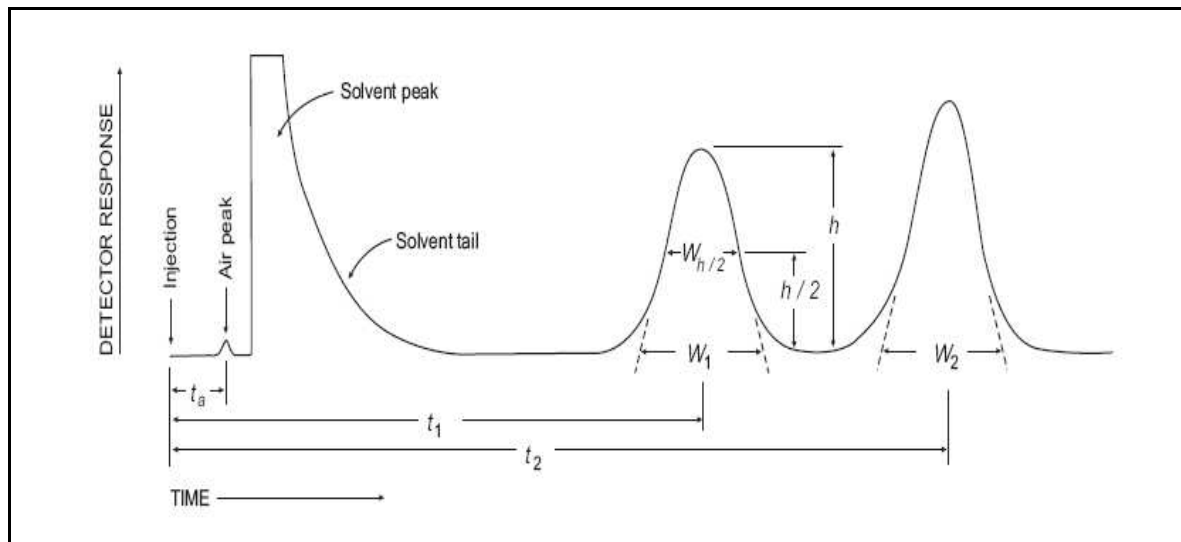

Figure 4.1. Chromatographic separation of two compounds [202].

4.1.3 Capacity Factor

The capacity factor or retention factor is the measure of compound retention on the column. It describes where the solute peak of interests elutes relative to the solvent or void volume, and is defined by Equation 4.5 and while column dead time is defined by equation 4.6.

$$k' = \frac{t_R - t_0}{t_0}$$

Equation 4.5

where,

t_R = Retention time of solute

t_0 = Column dead time

$$t_0 = \frac{V_m}{F}$$

Equation 4.6

where,

V_m = Column dead volume

F = Flow rate

4.1.4 Selectivity

Selectivity or separation factor is a measure of separation of two solutes, and is defined as:

$$\alpha = \frac{k'_B}{k'_A} \quad \text{Equation 4.7}$$

where,

k'_B = capacity factor for the strongly retained solute

k'_A = capacity factor for the rapidly eluting solute

The selectivity factor, α , is always greater than 1, and there are two main ways to improve resolution, illustrated in Figure 4.2. The first way is by increasing the sharpness of the peak whilst maintaining the peak centre constant, and the second way is by increasing the distance between the zone centres of the two peaks.

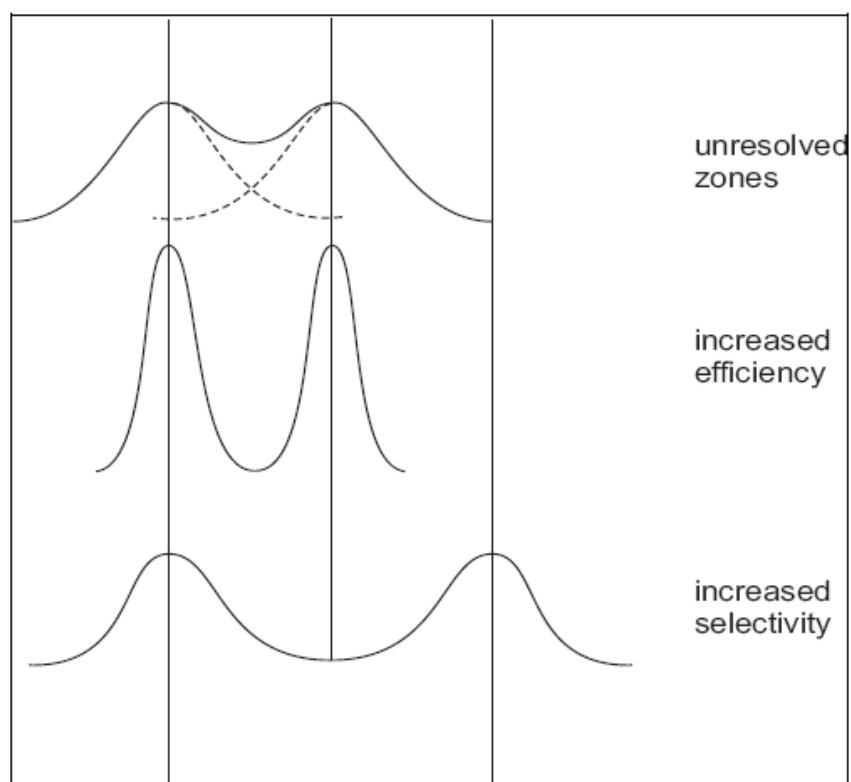

Figure 4.2. Illustration of increasing efficiency and increasing selectivity [202].

4.1.5 Tailing Factor

Ideally peaks should be Gaussian in shape, but in reality, that generally does not occur. Hence, peak shapes are characterised by tailing or asymmetry, and this is measured by the tailing factor or asymmetry factor. This parameter is important in method development because peaks with poor symmetry can result in poor resolution of peaks, imprecise quantification, undetected minor peaks co-eluting under the tail and poor retention reproducibility.

4.2 Application of HPLC

The procedure of liquid chromatography (LC) is widely known as High Performance Liquid Chromatography (HPLC) because in 1960s, columns packed with smaller particle sizes were developed, requiring sophisticated chromatographic equipment compared to their predecessors in order to result in the requisite high separation performance. Advantages of HPLC include the use of small sample size, lack of destruction of sample, high selectivity and wide accessibility/availability. Several different mechanisms of sample retention by the stationary phase in LC are possible (Table 4.1) [199]. The MP is generally a liquid, whereas the stationary phase varies. The various LC modes cover the separation of a wide range of analytes.

Table 4.1. Different liquid chromatographic modes.

LC Method		Stationary phase	Type of equilibrium	Analytes
Liquid-liquid or partition		Liquid adsorbed on a solid	Partition between immiscible liquids	MW < 10 000, polar, non-ionic
Liquid-bonded phase		Organic species bonded to a solid phase	Partition between liquid and bonded surface	MW < 10 000, polar, non-ionic
Liquid-solid		Solid particles	Adsorption	MW < 10 000, non polar
Ion exchange		Ion exchange resin	Ion exchange	
Size exclusion	Gel filtration	Liquid in polymer particles and the particles are hydrophilic	Partition/ sieving	MW > 10 000, Polar or ionic compounds
	Gel permeation	Liquid in polymer particles and the particles are hydrophobic		MW > 10 000, non-polar

Liquid bonded phase chromatography is the most widely-used because of its stability. The bonded phase columns have a limited sample capacity, therefore, small sample sizes have to be used to avoid column overload. There are two types of liquid bonded phase chromatography namely, normal phase and reversed phase. In normal phase chromatography, the stationary phase is polar and the MP is relatively non-polar, and is usually used to separate polar compounds. The retention times of polar compounds will be longer on normal phase chromatography. The most commonly-used type is reversed phase HPLC, where the stationary phase is non-polar relative to the MP performed using bonded octyl (C8) or octyldecyl group (C18) silane packings. The bonded phase packings are prepared by reaction of an organochlorosilane with a hydroxyl group of the silanol moiety. The organochlorosilanes often have a straight-chain octyl (C8) or octyldecyl group (C18).

4.3 Quantitative Analysis of Hypoxoside in African Potato Decoctions

4.3.1 Introduction

Reversed (RP) phase HPLC is a much-used analytical technique for the separation of chemical compounds in TM/CAM plant materials, as well as in pharmaceutical dosage forms. As previously mentioned, this method is versatile and not influenced by the volatility or stability of the analyte, hence, it can be used to separate various classes of analytes including TMs/CAMs [203]. The versatility of HPLC has enabled the use of a variety of detectors which include ultraviolet-visible (UV-VIS), mass spectroscopy (MS), evaporative light scattering detection (ELSD), fluorescence, electrochemical and even nuclear magnetic resonance (NMR). HPLC is used for the comprehensive qualitative analysis (fingerprinting) of TMs/CAMs, and used to compare profiles because of its ability to provide useful content information [204, 205]. Compounds with strong chromophores that absorb light in the wavelength region of about 200 to 800 nm are usually monitored using UV-VIS detection. Recent advances in technology have yielded a photodiode array (PDA) detector which is an extremely useful multi-wavelength detection technique. PDA detectors (also known as diode array detectors or DAD) can determine purity of each peak as well identify peaks with the aid of PDA spectral libraries. These features are very important in the analysis of TMs/CAMs, which usually contain many compounds, some of which may be present in only very small amounts. Compounds with differing electroactivity which may cause characteristic

voltametric responses can be selectively measured using electrochemical detection (ECD). Moreover, compounds that lack the necessary chromophores leading to poor UV-VIS can be detected by a refractive index (RI), or evaporative light scattering detector (ELSD) [206] as well as ECD.

Recent advances in mass spectrometric (MS) instrumentation have led to the incorporation of liquid chromatography coupled with mass spectroscopy (LC-MS-MS) for use in routine analysis [207]. This method allows for the identification and confirmation of the mass of compounds which can be of complex and diverse structures present in plant materials, and thus provides a powerful and useful application for both qualitative and quantitative analysis.

There is a dearth of information in the published literature describing the methods for the quantitative analysis of hypoxoside. A RP-HPLC method for the determination of hypoxoside distribution in three different *Hypoxis* species was reported by Vinesi *et al* in 1990 [208], however, no validation data and related information were provided.

In 1992, Betto *et al* [209] reported a RP-HPLC method using an acidic (pH 3.0) eluent to separate and determine some known norlignan glucosides isolated from Hypoxidaceae species. A gradient method was used, but here again, no validation data to support its application was provided, despite the claim that the method could be used for TMs and analysis of pharmaceutical preparations. Kruger *et al* [186] reported an HPLC method which was purported to be a quantitative analytical method for the analysis of hypoxoside and its metabolites in human plasma, urine and faeces. The MP consisted of guanidine hydrochloride and ammonium sulphate for the sorption enrichment of xenobiotics in biological fluids. Validation and quantitative data of this method were also not reported, despite its application for the analysis of biological fluids from human subjects who had taken part in a clinical study. This method was also applied to extracts of *H. rooperi* and *H. latifolia* for the identification of hypoxoside.

A validated RP-HPLC method used for the quantitative determination of hypoxoside in plant extracts including traditionally-prepared decoctions and in pharmaceutical dosage forms, has recently been reported by Nair *et al* [27]. The method used a binary mobile phase, detection was by PDA detector, and the method was characterised by high accuracy and precision.

Therefore, this method was adopted for the analysis of traditionally-prepared decoctions of AP. Since this method was routinely used in our laboratory, a mini-validation comprising repeatability of the calibration plots by another analyst, was carried out.

4.3.2 Equipment and Reagents

The HPLC system consisted of a Waters Alliance system, model 2690, equipped with a pump, an autosampler, an online degasser, and a model 2995 PDA UV detector (Waters, Milford, MA, USA). Samples were centrifuged using an IEC HN-SII[®] Centrifuge (Damon/IEC Division, Needham Hts, Massachusetts, USA), and the hypoxoside standard (87.9%) was qualified for use and provided by a colleague, Dr. Patnala.

4.3.3 Chromatographic Conditions

Separation was achieved on a Phenomenex[®] Luna C₁₈ (2) (5 µm, 150 mm × 4.6 mm i.d) column at 23 ± 2 °C, using acetonitrile: water (85:15 v/v) as the mobile phase. The flow rate of the mobile phase was 1 ml/min, 10 µl samples were injected, and hypoxoside elution was monitored by UV detection at λ = 260 nm. The internal standard used was sulphamerazine (SMZ).

4.3.4 Methods

The absorption spectrum of hypoxoside was determined by HPLC coupled with a DAD [27]. The purity of the standard provided was also assessed using the HPLC-DAD method, and the structure was confirmed using LCMS. Calibration plots were prepared using a range of calibration standards consisting of 5, 10, 20, 40 and 80 µg/ml.

4.3.5 Results and Discussion

The hypoxoside standard was readily soluble in methanol and water. The UV spectrum is depicted in Figure 4.3 below, and corresponds to the UV scan of hypoxoside previously reported [27, 186].

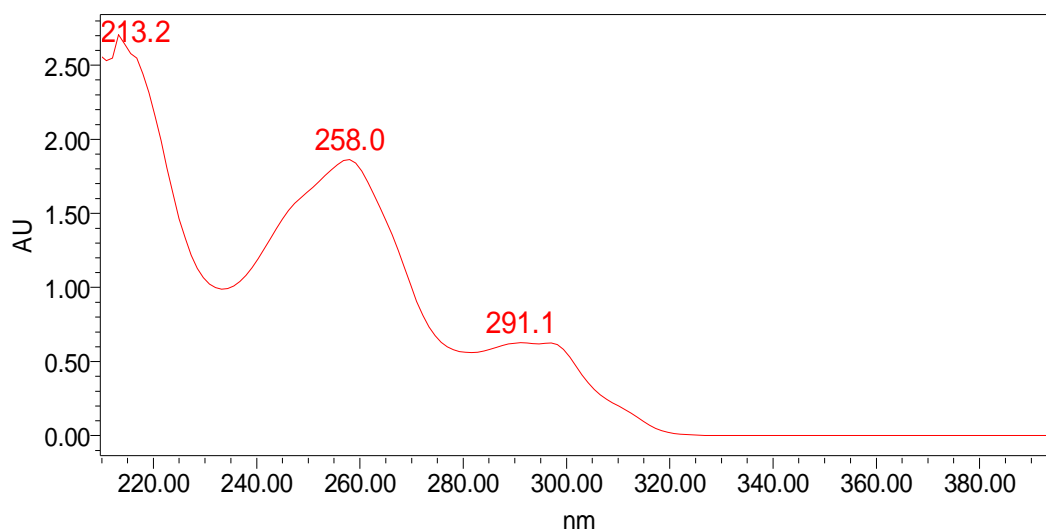

Figure 4.3. UV absorption spectrum of hypoxoside.

The calibration plots of hypoxoside were all linear using un-weighted regression analysis (Table 4.2).

Table 4.2. Linearity

DAY	Y -intercept	Gradient of calibration curve	Correlation coefficient
1	-0.021	0.031	0.999
2	-0.045	0.034	0.999

A typical chromatogram showing the separation of hypoxoside and the internal standard (SMZ) is shown in Figure 4.4.

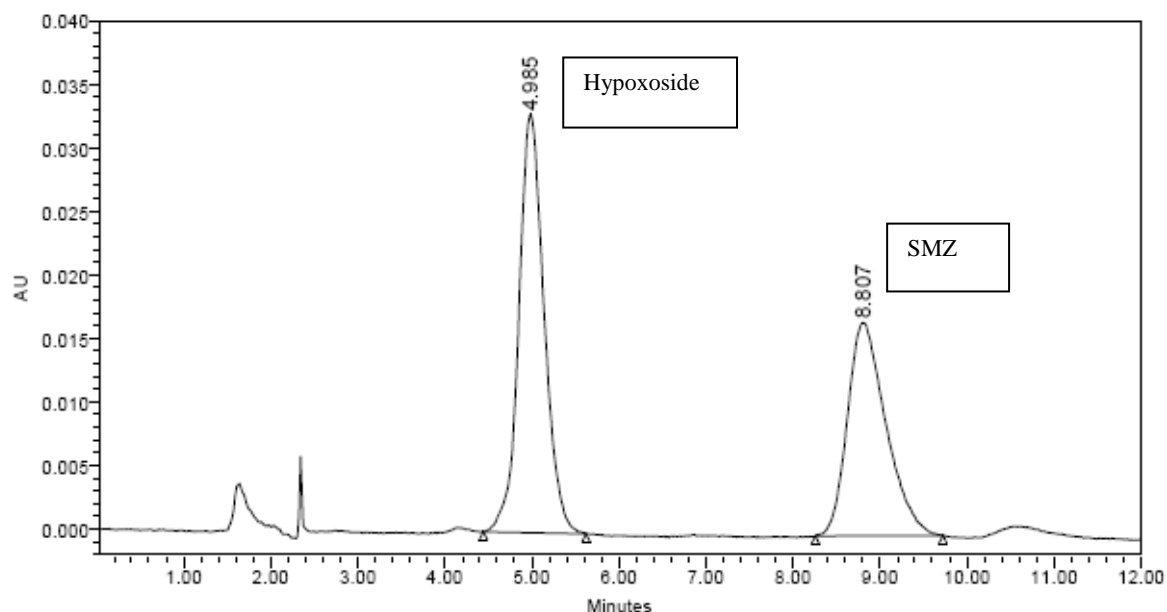

Figure 4.4. Chromatogram of calibration standard of hypoxoside with SMZ.

4.3.6 Conclusions

The data from the peak purity of hypoxoside using HPLC-UV confirmed the absence of UV absorbing impurities. The hypoxoside standard was thus sufficiently pure (87.9%) and was acceptable for use as an analytical reference for quantitative analysis.

4.4 DEVELOPMENT AND VALIDATION OF A HPLC METHOD FOR THE DETERMINATION OF EFAVIRENZ IN HUMAN PLASMA

4.4.1 Introduction

A bioanalytical method is essential for the evaluation and interpretation of pharmacokinetic data following administration of medicines to humans. There are three main analytical phases involved; viz, method development, method validation and successful application of the method. These stages are all critical for the development of an accurate, precise and reproducible method, which has the necessary selectivity and sensitivity to measure the relevant drug in biological fluids.

4.4.2 Review of Published Methods

EFV has been analysed in biological fluids and tissues using various methods which have been published in the scientific literature. Most analytical methods for the determination of EFV have involved HPLC, using Ultra Violet (UV) detection (Table 4.3) as well as other detection methods, such as mass spectroscopy [210] and fluorescence detection [211]. Capillary electrophoresis [212] has also been used. In some of those methods, EFV was determined simultaneously with other antiretrovirals.

Table 4.3 summarizes the various HPLC - UV methods which are associated with high recoveries of EFV from plasma and adequate Lower Limit of Quantification (LLOQ) (~ 100 ng/ml) for use in pharmacokinetic studies. Sample volumes ranged from 200 - 900 μ l plasma, whereas a smaller sample size of 100 μ l was used by Kappelhoff *et al* [213]. Several of these methods use liquid-liquid extraction, or solid phase extraction, to extract EFV from plasma whereas a protein precipitation method followed by a dilution step with distilled water has also been used [213]. The main objective of this work was, therefore, to develop a rapid, accurate, precise, selective, sensitive and cost-effective bioanalytical method for the determination of EFV in human plasma.

Table 4.3. Review of the analytical methods used for the determination of EFV in human plasma.

Stationary phase	Analyte	Mobile phase	Extraction procedure	Recovery (%)	LLOQ (µg/ml)	Lower QC and precision at lower QC (%)	Injection volume (µl)	Flow rate (ml/min)	Internal standard	Regression analysis	Reference
C18 Symmetry® (250 mm × 4.6 mm ID, 5 µm)	EFV and others	Gradient condition 0.01 M KH ₂ PO ₄ and Acetonitrile	SPE	113.9	0.1	0.625 (8.3)	20	1.0	NR	Unweighted	[214]
Symmetry® shield RP8 (100 mm × 3.0 mm ID, 5 µm)	EFV and other ARVs	Acetonitrile : 50 mmol/L Formic acid (40:60)	LL	96	0.1	0.3 (5.1)	80	0.75 then increased to 1.6	NR	Weighted 1/(concentration) ²	[215]
Nova Pak® C18 (100 mm × 8 mm ID, 4 µm)	EFV and other ARVs	Acetonitrile: methanol: tetramethylammonium perchlorate	LL	81 to 97	0.047	0.94 (7.7)	25	1.5	NR	NR	[216]
C 18 , (150 mm × 4.6 mm ID, 5 µm)	EFV alone	10 mM Phosphate buffer : acetonitrile (55:45)	LL	95 to 106	0.0625	0.25 (6.8)	20	2.4	nefazodone	NR	[217]
Luna® Phenomenex (250 mm × 4.6 mm ID, 5 µm)	EFV and rifampicin	Sodium phosphate buffer: acetonitrile: methanol (40:45:15) initially then gradient	LL	98	0.05		50	1.0	NR	NR	[218]
Zorbax® Extend C18 (150 mm × 2.1 mm ID, 5 µm)	EFV and nevirapine	25 mM triethylamine in water: acetonitrile (65:35)	P	85.0 to 95.8	0.1	0.250(5.6)	25	0.2	carbamazepine	Weighted, 1/(concentration) ²	[213]
Zorbax® C18 (75 mm × 4.6 mm ID, 3.5 µm)	EFV alone	Acetonitrile: phosphate buffer pH 3.5 (50:50)	LL	>78		0.2 (8.6)		0.8	nelfinavir	Weighted, 1/(concentration)	[219]
Supelcosil® LC8 (150 mm × 4.6 mm ID, 3 µm)	EFV alone	Acetonitrile: 50 mM potassium phosphate with triethylamine added to 1%, pH adjusted to 5.75 with orthophosphoric acid (55:45)	SPE	102 to 109	0.1	0.2 (8.6)	80	1.0	L-737,345	Weighted, 1/(concentration)	[220]
XTerra® RP 18 (150 mm × 2.1 mm ID, 5 µm)	EFV alone	Acetonitrile: 67 mM potassium dihydrogen phosphate, adjusted to pH 7.4 with sodium hydroxide 32% (50:50)	LL	96.2	0.025	0.2 (6.9)	100	0.2	A86093	unweighted	[221]

Stationary phase	Analyte	Mobile phase	Extraction procedure	Recovery (%)	LLOQ (µg/ml)	Lower QC and precision at lower QC (%)	Injection volume (µl)	Flow rate (ml/min)	Internal standard	Regression analysis	Reference
Zorbax® C18 (150 mm × 2.1 mm ID, 3.5 µm)	EFV and other ARVs	A. 50 mM phosphate monobasic: methanol (85:15) B. A: acetonitrile: methanol (25:60:15), gradient	SPE	>90	0.025	0.12 (2.1)	80	0.9 then 1.1	midazolam	weighted	[222]
C18 Symmetry® (250 mm × 4.6 mm ID, 5 µm)	EFV and other ARVs	A. Acetonitrile: 0.025 M tetramethylammonium perchlorate in 0.2% aqueous trifluoroacetic acid (T) (55:45) B. methanol: T (55:45), gradient	LL	80	NR	0.5	50	0.9	NR	unweighted	[223]
Discovery® C8 (250 mm × 4.6 mm ID, 5 µm)	EFV and other ARVs	A. 25 mM potassium phosphate buffer pH 3.1 B. Acetonitrile C. methanol (gradient)	LL	90.7	0.05	0.204 (6.3)	NR	1.5	NR	Weighted, 1/(concentration) ²	[224]

Abbreviations:

LL- Liquid-liquid; SPE – Soli phase extraction; P- precipitation; NR- not reported.

4.4.3 *Methods*

4.4.3.1 *HPLC Method Development*

The main objectives in the development of a suitable bioanalytical method for the analysis of EFV in plasma includes the following:

- separation of EFV from matrix components
- resolution of EFV peak from other peaks
- accurate and precise determination of the amount of EFV in human plasma
- successful analysis of study samples within a short period of time.

Based on these objectives, a suitable HPLC method was developed by evaluating and optimising the chromatogram functionality parameters that influence successful outcomes following application of the method.

4.4.3.2 *Reagents and Chemicals*

EFV was obtained as a donation from Aspen Pharmacare (Port Elizabeth, South Africa) and diclofenac sodium from the Biopharmaceutics Research Institute (BRI), Rhodes University. HPLC grade acetonitrile and methanol were purchased from Romil Ltd., Cambridge, United Kingdom and formic acid (99.9%) was sourced from Associated Chemical Enterprises Pty, Ltd Johannesburg, South Africa. Water was purified by reverse osmosis and filtration through a Milli-Q purification system (Millipore, Milford, MA, USA). Human plasma with potassium edentate (K-EDTA) as an anticoagulant was obtained from the South African National Blood Services, Eastern Cape Headquarters (Port Elizabeth, South Africa) and was stored at $-10 \pm 2^{\circ}\text{C}$.

4.4.3.3 *Equipment and instrumentation.*

The HPLC system consisted of a Waters Alliance system, model 2690, equipped with a pump, an autosampler, an online degasser, and a model 2995 PDA UV detector (Waters, Milford, MA, USA). Chromatographic separation was achieved on a reversed phase HPLC column and guard column (Phenomenex Luna[®] C₁₈ (2) ,5 μm, 150 X 2.0 mm i.d. and Phenomenex Luna[®] C₁₈ guard column, 4 mm × 3.0 mm i.d. obtained from Phenomenex,

Macclesfield, UK). An Eppendorf[®] model 5415 centrifuge was used (Eppendorf Gerätebau Netheler & Hinz GmbH, Hamburg, Germany) and the nitrogen evaporator (N-EVAP[®] Analytical Evaporator, Organomation Associates Inc., Massachusetts, USA) was used to evaporate samples to dryness. Vortexing was accomplished using a Lab Dancer vortexer (IKA[®] Laboratory Equipment, Straufen, Germany).

4.4.3.4 Column Selection

The choice of HPLC column must take into account the molecular structure and chromatographic behaviour of the analyte, amongst others. EFV is a weakly basic molecule ($pK_a = 10.2$), soluble in methanol and is hydrophobic. In RP-HPLC, EFV will preferentially partition from the MP onto the stationary phase, resulting in increased retention times. The bonded phase of the stationary phase in RP-HPLC affects the retention time of the analyte, with C_{18} columns giving slightly longer retention times. These columns are generally stable even at low pH, thereby increasing column life-time. Since the aim of this study was to develop a rapid analytical method with run time less than ten minutes, a C_{18} column was chosen and the composition of the MP was developed and optimised accordingly.

A reversed phase Luna C_{18} (2) (Phenomenex[®], Macclesfield, Cheshire, England) was identified for use for the analysis of EFV in human plasma, and consisted of a 5 μm particle size with a pore diameter of 100 Å, internal diameter of 2.0 mm and column length was 150 mm. This particular column packing and geometry allows for fast diffusion of the analyte in and out of the stationary phase, thereby yielding high efficiency [201]. A Phenomenex Luna[®] guard column (4 mm \times 3.0 mm i.d) was used to protect the column.

4.4.3.5 Choice of Internal Standard

Use of an internal standard was deemed necessary to compensate for possible variability due to sample manipulation and extraction where errors can thereby be minimised. An internal standard (IS) is a different chemical compound from that of the analyte. The IS must be well resolved from the analyte and mimic the analyte behaviour during pre-treatment. Ideally, an IS should be structurally similar to the analyte. Therefore, in the case of EFV where structurally similar compounds are not readily available, other compounds were assessed for

suitability. Since EFV is a weakly basic compound, basic compounds were evaluated for suitability. The basic drugs which were readily available namely, acyclovir, carbamazepine, diazepam and Propranolol, were assessed for suitability as IS. All of these drugs were eluted within 2.5 min, and would likely not be separated from interfering substances present in plasma, and close to the void volume of the column. Hence, none of the drugs were considered to be suitable as an IS. Hence, some acidic drugs were tried such as diclofenac sodium (DIC Na), flurbiprofen (FLU), ibuprofen and ketoprofen, and the corresponding retention times are shown in Table 4.4.

Table 4.4. Acidic compounds investigated.

Drug	Retention time (min)
diclofenac sodium	6.8
flurbiprofen	6.4
ibuprofen	7.6
ketoprofen	4.0

The retention time for ketoprofen was too short, whereas all the other compounds eluted later (> 6 min), and were considered as possible candidates for use as an IS. Flurbiprofen (FLU) was initially chosen as the preferred IS because it has a maximum UV absorbance (λ_{\max}) at 247 nm [90], which is similar to the λ_{\max} of EFV. The initial method development was done using FLU, but subsequently when extraction procedures for EFV from plasma were investigated, interference between FLU and compounds in plasma precluded the use of FLU as IS. DICNa was subsequently chosen as the IS, although its λ_{\max} was at 275 nm. However, this proved advantageous since no interference from plasma components were seen at 275 nm. In order to monitor EFV at its λ_{\max} of 247 nm, the use of a PDA detector was used whereby both EFV and the IS could be simultaneously detected at the two different wavelengths (Figure 4.5).

4.4.3.6 Choice of Solvent for EFV

The solvent of a sample may affect the quality of the eluting peaks, especially with respect to peak shape. EFV was dissolved in MeOH, ACN and MP to produce the same concentrations. The same amount of EFV was loaded into the column, and the peak heights were compared. The sample dissolved in MP gave sharper/higher peaks (Fig 4.6), hence, MP was chosen as the solvent for solutions of EFV.

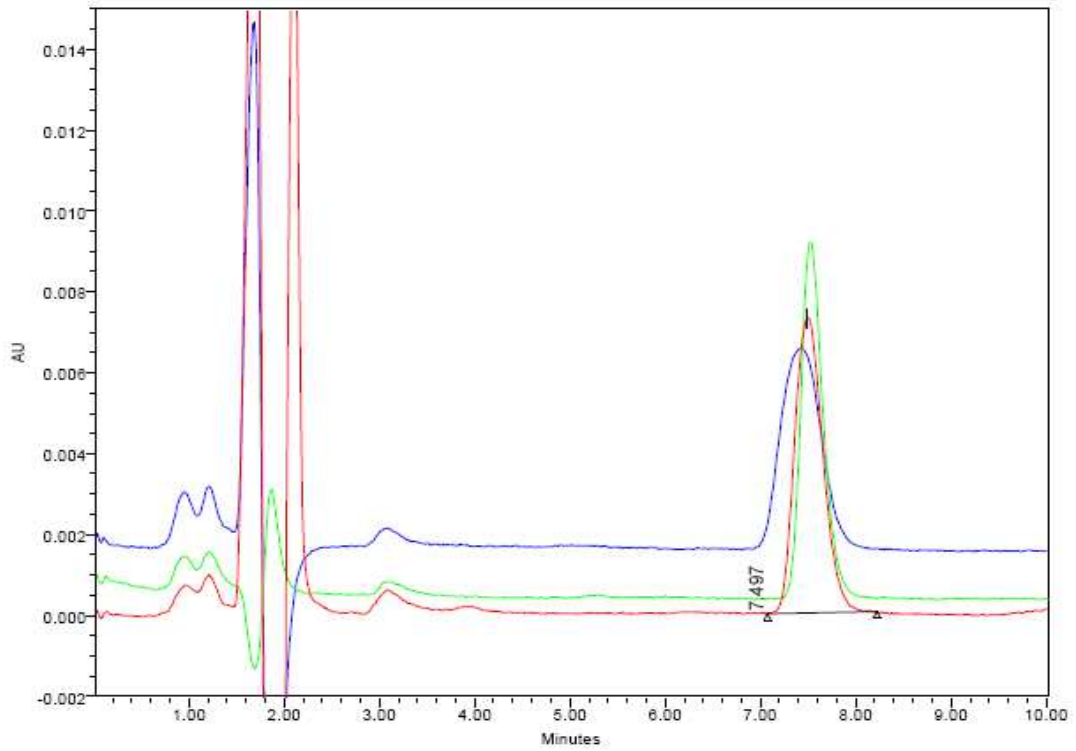

Figure 4.5. Chromatogram of EFV peaks dissolved in ACN (blue), MeOH (red) and MP (green).

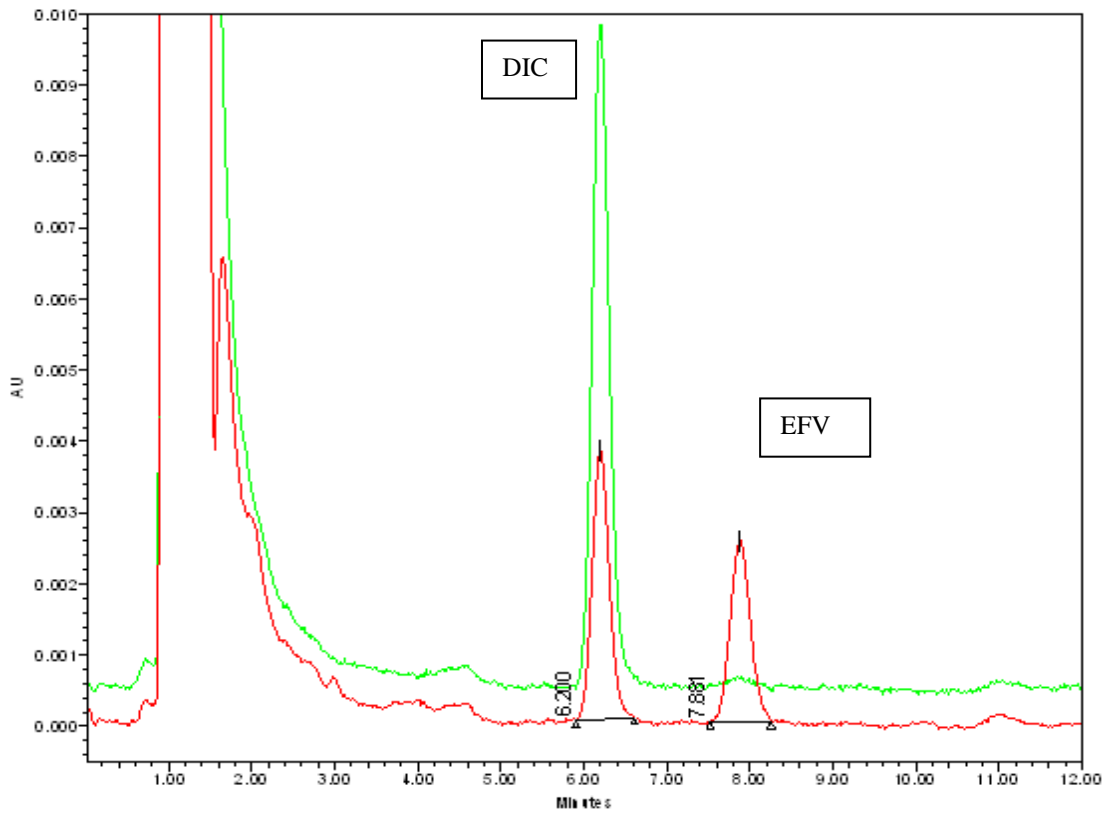

Figure 4.6. A chromatogram of a spiked plasma sample containing EFV (red: $\lambda=247$ nm) at a concentration of 1.5 $\mu\text{g/ml}$ and IS (green: $\lambda=275$ nm) at a concentration of 4.0 $\mu\text{g/ml}$.

4.4.3.7 Mobile Phase (MP) Preparation and Selection

The composition of the MP is very critical to separation of compounds as it affects the functionality of the chromatographic system. Changes in MP composition are the most effective and convenient; hence during optimisation of the separation, this is usually the first step to be undertaken. The changes that can be made to the MP include pH, solvent polarity, and flow rate, amongst others. An isocratic mode was used, and the initial MP composition consisted of acetonitrile: 0.01 M formic acid (56:44% v/v). The MP was filtered under reduced pressure through a 0.45 µm Durapore (PVDF) filter (Millipore, Bedford, MA, USA), and degassed using an Eyela Aspirator A-25 (Tokyo Rikakikai Co. Ltd, Tokyo, Japan) prior to use.

In reversed phase chromatography, sample retention increases with an increase in hydrophobicity of compounds, therefore, increasing ionisation of ionisable compounds will reduce their retention times. Since EFV is a weak base, a decrease in pH results in ionisation of EFV rendering this compound less hydrophobic. Initially, the concentration of formic acid was varied to assess separation parameters, and the 0.1 M concentration yielded the lowest tailing factor and the highest value of column efficiency.

An increase in MeCN content resulted in a decrease in resolution and a reduction in capacity factor and retention time. At a MP composition of 50:50 MeCN/0.1 M FA, the tailing factor was relatively low. Addition of methanol (MeOH) and reduction of volume of formic acid resulted in reduction of retention time of EFV to 7.7 min, therefore, the run time was less than 10 minutes.

The flow rate of 0.30 ml/min gave a capacity factor > 5 . This flow rate was the most suitable and also cost-effective because less MP is used during analysis. The temperature of the column can affect the retention and separation of compounds, hence, effect of column temperature on the separation and elution of EFV and IS was investigated. The peaks were sharper when the column temperature was at 40 °C

4.4.3.8 Sample Volume (Injection volume) Optimisation

The injection volume should be adequate such that the peak area of the smallest concentration is easily measured. In this case, the sample volume had to be adequate to allow re-injection of sample if required, without the need for re-extraction. Therefore, the injection volume was varied to find the smallest volume possible to result in an acceptable peak (Table 4.5). A 10 µl injection volume was considered adequate.

Table 4.5. Effect of injection volume on peak area

Injection volume (µl)	Efavirenz peak area
10	12037
15	17172
20	22168

The following chromatographic conditions were finally chosen for the analysis of EFV (Table 4.6)

Table 4.6. Final chromatographic conditions for the determination of EFV

Column temperature	40 ± 2 °C
Flow rate	0.3 ml/min
Mobile phase	ACN: 0.1 M FA: MeOH (52:43:5 v/v)
Injection volume	10 µl
IS	DICNa

4.4.3.9 Plasma Sample Preparation

Plasma contains various endogenous substances which can interfere with the quantitative analysis of EFV, therefore, a suitable method of extraction of EFV from plasma was developed. The objective was to develop a rapid method which would be cost-effective, accurate, precise and have the necessary sensitivity to quantitatively determine EFV in the plasma from a clinical study involving human subjects.

4.4.3.9.1 Liquid-liquid Extraction

The first extraction procedure investigated involved liquid-liquid extraction where the sample (compound to be analysed) is partitioned between two immiscible phases, one phase being

aqueous, and the other an organic solvent. Polar compounds prefer the aqueous phase, whilst the non-polar, hydrophobic compounds preferentially partition into the organic phase. Hydrophobic analytes may be recovered from the organic solvent by evaporation, while analytes in the aqueous phase may be directly injected onto the column.

Ethyl acetate (EtAc) was investigated as an extraction solvent, and the initial method which utilized FLU as internal standard was as follows:

- 200 μl EtAc containing 1.0 $\mu\text{g/ml}$ FLU was added to an aliquot of 100 μl of plasma in an Eppendorf[®] safe lock tube, 1.5 ml capacity (Eppendorf Ag, Hamburg, Germany).
- The mixture was vortexed on a Lab Dancer for 50 s and centrifuged at 10 000 g for 10 min in an Eppendorf centrifuge 5415 (Eppendorf Gerätebau Netheler + Hinz GmbH, Hamburg, Germany).
- The resultant supernatant (about 180 μl) was removed and placed in a micro-insert (Separations Pty Ltd,) and the EtAc was evaporated to dryness using a stream of nitrogen in an N-EVAP[®] Analytical Evaporator (Organomation Associates Inc., Massachusetts, USA).
- The dried sample residue was re-constituted with 100 μl of MP. The solution was vortexed for 1 min and 10 μl was injected directly onto the column.

The chromatogram of the blank plasma extract did not show any interference on the EFV and IS peaks. However, recovery of both EFV and FLU was low. In an attempt to improve recovery, several extractions, using various volumes of EtAc, were attempted but, this did not improve the recovery. Since the EtAc method yielded poor extraction efficiency, another extraction procedure was investigated.

4.4.3.9.2 Sample Preparation by Protein Precipitation

An extraction procedure based on the method used by Kappelhoff *et al* [213] was investigated and subsequently adapted with several modifications. Various steps of the precipitation method were manipulated to yield high recovery, with good accuracy and precision. These were the precipitating solvent, dilution, and vortex times. Extraction efficiency of EFV and FLU was assessed after dilution with MP or MeCN, and also without dilution. The supernatant following precipitation with MP which was undiluted gave higher

and sharper peaks. Overall, as the mixing time increased, the %RSD improved, and the values were lowest after vortexing for 50 s. Variability of the peak areas of EFV was relatively high, with RSD values ranging from 9.05 to 23.30%. However, mixing of the supernatant by vortexing for 10 s before injection reduced the variability.

During the development of this extraction procedure, plasma components in some of the plasma batches interfered with the elution of the IS, FLU (Figure 4.7). This necessitated the identification of an alternative IS. FLU was subsequently replaced with diclofenac sodium (DICNa) as IS. and this proved to be successful (Figure 4.8).

The following extraction procedure was subsequently used for the analysis of plasma samples from study subjects.

- Plasma samples (100 μ l) were transferred into 1.5 ml Eppendorf[®] tubes.
- An aliquot (200 μ l) of DICNa in MP (4 μ g/ml) was added.
- Mixture was vortexed for 50 s and centrifuged at 10 000 g for 10 min
- The supernatant (100 μ l) was transferred into a 150 μ l micro- insert vial and vortexed for 10 s.
- Ten microlitres injected onto the column

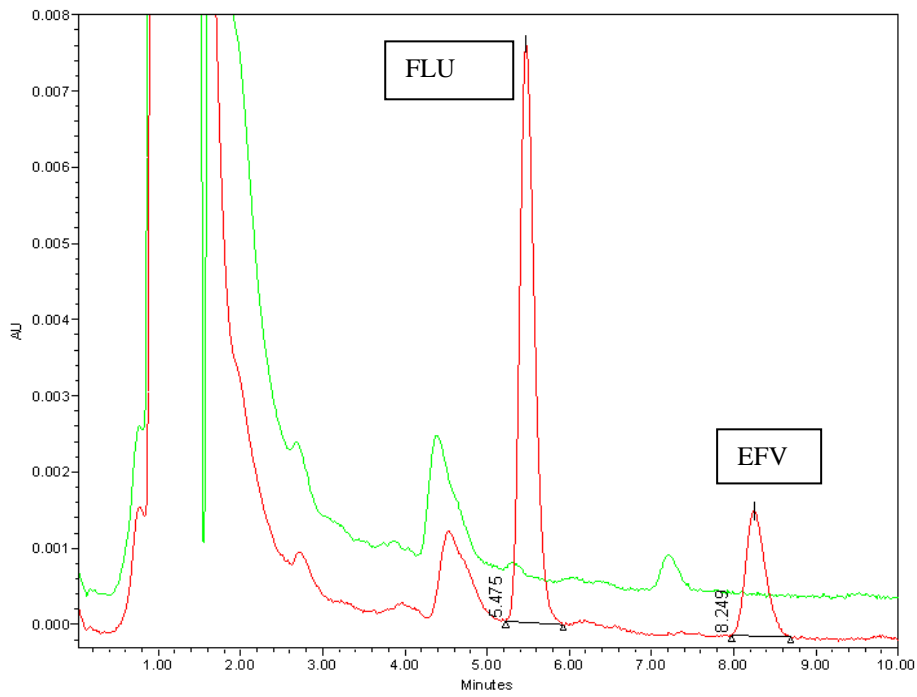

Figure 4.7. A blank plasma extract (green) and spiked plasma sample containing EFV and FLU as IS (red - $\lambda=247$ nm).

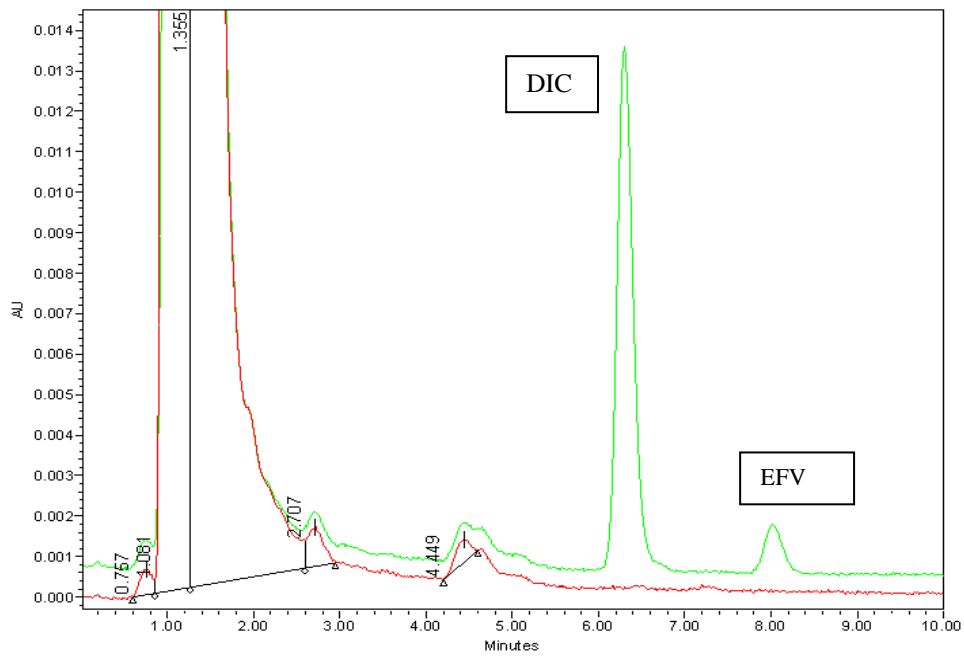

Figure 4.8. A blank plasma extract (red) and a spiked plasma sample containing EFV and DICNa as IS (green: $\lambda=275$ nm).

4.4.3.10 *Validation of HPLC-UV Method*

Method validation establishes the performance of the analytical procedure. Parameters that can affect the reliability and reproducibility of the data generated by the method are assessed and results documented [225]. These are: selectivity, accuracy, recovery, precision, sensitivity, linearity and reproducibility. In addition, the stability of stock solutions, unextracted and extracted samples, also need to be assessed. A full validation according to FDA Guidance on Validation of Bioanalytical Methods [225] was performed.

4.4.3.10.1 Preparation of Standards and Quality control (QC) samples

Stock solutions of EFV and DICNa in mobile phase were prepared by weighing out appropriate amounts of the analyte and IS on a Mettler Toledo AG 135 balance (Mettler Toledo, Zurich, Switzerland), and dissolving them in MP to yield concentrations of 1mg/ml. For DICNa, an appropriate amount of the stock solution was measured and diluted to yield a working solution of 4 µg/ml. An appropriate aliquot of the EFV stock solution was transferred to a volumetric flask, and plasma was added by weight on a Mettler Toledo AG 135 balance (Mettler Toledo, Zurich, Switzerland) to produce a concentration of 10 µg/ml. The specific gravity of plasma, 1.025 g/ml, was used [226] to convert the weight to volume. Plasma weight was used since it is considered to be more accurate and avoids errors due to frothing and the formation of air bubbles which make it difficult to make up to volume in a volumetric flask. The plasma stock solution was gently shaken for 1 hr on a shaker (The Chemical Rubber Co., Cleveland, Ohio, USA). Calibration standard samples were prepared from a different stock solution to that of the QC samples. Concentrations of the QC plasma samples were 0.30, 1.5 and 7.5 µg/ml for the low, medium and high samples, respectively.

4.4.3.10.2 Selectivity

Selectivity is the capability of a method to differentiate and measure the analyte in the presence of components of the matrix. In the case of plasma, the components include various endogenous substances, drug metabolites and also exogenous xenobiotics. Plasma from six different sources was evaluated for interference with the analyte (EFV), and the internal standard, DICNa. Blank plasma samples were extracted and compared with spiked plasma extracts containing EFV at the LLOQ.

4.4.3.10.3 Accuracy

The accuracy of a method is a measure of how close the measured mean value is to the true value. Three sets of QC samples at low, medium and high concentrations were prepared by accurately weighing an appropriate amount of EFV plasma stock solution, and diluting with blank plasma. These were extracted and analysed in the same manner as calibration standards. Using the peak area ratio of EFV/IS, concentrations of the samples were back calculated, using regression analysis of the calibration plot. The calculated concentration was used to determine the accuracy of the method. Specifications for accuracy of the QC samples in this method were set at 85-115%. Intra-day and inter-day accuracy was evaluated over three days.

4.4.3.10.4 Recovery

Recovery of a method is a measure of extraction efficiency to determine how much of the added analyte can be extracted from the matrix. It is obtained by comparing the detector response of the extracted analyte to the detector response of a pure standard solution. Three QC plasma samples containing EFV were prepared at low, medium and high concentrations. Five replicates were prepared at each concentration. The average peak area ratios of standards in MP were compared to those of plasma extracts.

4.4.3.10.5 Precision

The degree of scatter between a series of measurements obtained from multiple sampling of a single homogenous sample is referred to as precision. It is a measure of variability of the method, and can be divided into: repeatability, intermediate precision and reproducibility. Variability of the method was assessed using low, medium and high QC samples. Replicates of each QC samples were extracted five times, and the supernatant injected for analysis. The %RSD values for each concentration were calculated, and the acceptance criteria were set at %RSD values of less than 15%.

4.4.3.10.6 Determination of Lower Limit of Quantitation (LLOQ)

The LLOQ is the lowest amount of the analyte in a sample that can be quantitatively determined with acceptable accuracy and precision [227]. Five separate plasma samples at the LLOQ were extracted, and the variability and accuracy of the extraction method were assessed.

4.4.3.10.7 Linearity

Linearity is the measure of the relationship between the concentration of the sample and the corresponding detector response. A calibration curve was prepared from seven calibrators, including one at the LLOQ. Each calibration standard was extracted three times, and an average of the three extracts was used to construct the plot. The concentration range of the calibration curve was 0.2 to 10 µg/ml. The acceptance criteria for the calibration plot was that variation of more than six calibration standards should be better than 15% RSD, and that of the LLOQ should be better than 20% RSD.

4.4.3.10.8 Stability

Stability of stock solution of EFV and DICNa was assessed after storage in the refrigerator at 2-8 °C for 1 week, and on the bench top ($22 \pm 2^\circ\text{C}$) for 4 hr. The stability of the stock solutions should be assessed for the anticipated storage period [228], which, for the refrigerator, was one week, and for the bench top, four hours. The peak areas of the stored samples were compared to freshly prepared samples, with acceptance criteria set to be within 5-7% RSD.

Short-term stability is evaluated to assess the extent of degradation of the analyte during preparation or extraction of study samples prior to analysis. It is also referred to as bench-top or process stability [228]. Two sets of stability samples were used, set one was removed from the chest freezer defrosted in a water-bath at ambient temperature, and kept on the bench for six hours, and the second set was removed from the freezer at the end of the six hours, and defrosted in a water-bath. After defrosting the second set, both sets were analysed and the calculated concentration of EFV compared between both sets, as well as freshly prepared

samples. The acceptance criteria for the difference between the two sets of samples were set to be within 15% of each other, and within 15% of nominal values.

The long-term stability of samples was assessed to determine the time period of stability from sample collection to sample analysis. Long term stability was assessed over a period of two months. Samples were stored in a deep freezer at -10 °C and analysed after 7, 30 and 60 days, and compared to freshly prepared samples. The acceptance criteria for the difference between the two sets of samples were set to be within 15% of the nominal concentration.

The FDA guidance recommends that a sample must be exposed to at least three freeze thaw cycles to ascertain stability [225]. The reasons for freeze-thaw stability include failed analytical runs and the use of incorrect dilutions when preparing samples. Freshly prepared samples were stored in a chest freezer (-10 °C) for 24 hr, then defrosted in a water-bath at ambient temperature. Once thawed, the samples were re-frozen for 12 hr, again defrosted and this procedure was repeated once more, thus samples were exposed to three freeze thaw cycles and then analysed. This was done in triplicate for the low, medium and high QC samples. The concentration of EFV in the freeze-thaw samples was compared to freshly prepared samples, and the concentrations of the freeze-thawed samples should be within 85% to 115% of the nominal concentration.

It was anticipated that during analysis of QC samples, calibration samples and study samples would be prepared and analysed in a serial manner, which could result in these samples staying in the autosampler for a long period. Therefore, there was a need to perform stability studies on processed samples. This is referred to as on-instrument stability. Triplicates of QC samples were evaluated for stability on the instrument for 24 hr. Extracted samples were analysed immediately after preparation, and kept on the instrument carousel for 24 hr before re-analysis. Actual concentrations of the samples were calculated from the regression equation, and compared to nominal concentrations; the target difference was set at within 15% of the nominal concentration.

Re-injection or re-analysis samples were injected and left in the instrument for 24 hr, and re-injected. On re-injection, the concentrations of samples were compared to freshly prepared

samples, and the back calculated concentrations. The difference target was set at within 15% of the nominal concentration.

4.4.3.11 Results and Discussion

4.4.3.11.1 Selectivity

Figure 4.9 depicts chromatograms showing a blank plasma extract (A) and the response from a spiked plasma sample containing EFV ($\lambda=247$ nm) at the LLOQ (B), and the IS ($\lambda=275$ nm) and (C) plasma samples of a subject collected two hours following the oral administration of a 600 mg EFV tablet. There were no interfering endogenous compounds in any of the different batches of human plasma obtained from six different sources.

4.4.3.11.2 Accuracy

Intra-day (Table 4.7) and inter-day (Table 4.8) accuracy were within the set criteria, and found to be between 12.3 and 17.7% at the LLOQ, and between -5.8 and 9.1% for the QC samples.

Table 4.7. Inter-day Accuracy.

QC	Day	Mean (n=5) Nominal concentration ($\mu\text{g/ml}$)	Mean (n=5) calculated standard concentration ($\mu\text{g/ml}$)	Accuracy (%)	RSD (%)
Low	1	0.2956	0.3225	109.1	3.7
	2	0.3118	0.2991	95.9	4.7
	3	0.3171	0.3449	108.8	4.2
Medium	1	1.4888	1.4881	99.9	0.8
	2	1.5627	1.4749	94.5	1.7
	3	1.5711	1.5253	94.4	1.2
High	1	7.4261	7.4138	99.8	2.6
	2	7.8119	7.5101	96.2	2.2
	3	7.9151	8.0910	102.2	3.4

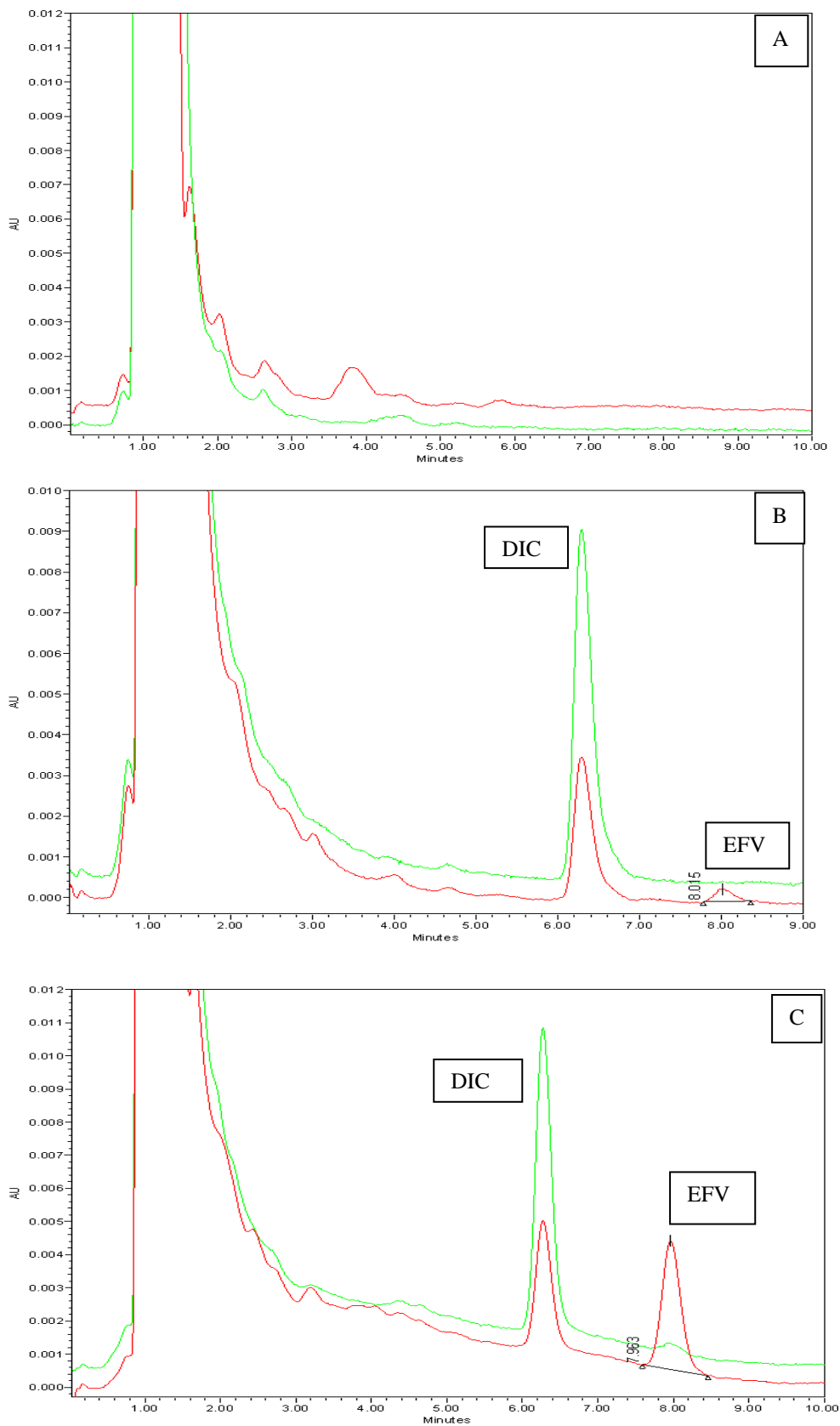

Figure 4.9. A blank plasma extract (red - $\lambda=247$ nm and green - $\lambda=275$ nm) and B = spiked plasma sample containing EFV (red: $\lambda=247$ nm) at the LLOQ and IS (green: $\lambda=275$ nm) and (C) plasma of a volunteer two hours after the oral administration of a 600 mg EFV tablet to a human subject.

Table 4.8. Intra-day Accuracy of extracted plasma samples.

Replicates	LOW QC			Medium QC			HIGH QC		
	Nominal concentration (µg/ml)	Calculated standard concentration (µg/ml)	Accuracy (%)	Nominal concentration (µg/ml)	Calculated standard concentration (µg/ml)	Accuracy (%)	Nominal concentration (µg/ml)	Calculated standard concentration (µg/ml)	Accuracy (%)
1	0.2956	0.3254	110.1	1.4748	1.4724	99.8	7.4369	7.1163	95.7
2	0.2940	0.3270	111.2	1.4847	1.4734	99.2	7.3710	7.5261	102.1
3	0.2958	0.3368	113.9	1.4946	1.4854	99.4	7.3977	7.4939	101.3
4	0.2962	0.3169	107.0	1.5028	1.5207	101.2	7.4758	7.5409	100.9
5	0.2965	0.3065	103.4	1.4874	1.4886	100.1	7.4493	7.3916	99.2
Mean	0.2956	0.3225	109.1	1.4888	1.4881	99.9	7.4261	7.4138	99.8
RSD (%)	0.3	3.5	3.7	0.7	1.3	0.8	0.56	2.4	2.6

4.4.3.11.3 Recovery

Extraction efficiencies of EFV from plasma were 94.1, 92.7 and 94.1% for the low, mid and high QC samples, respectively. The % relative standard deviation (RSD) values ranged from 1.4 to 2.1. Chromatograms of standards of EFV at mid QC and IS in mobile phase, and of a plasma sample spiked with EFV at mid QC and DIC is shown in Figure 4.10.

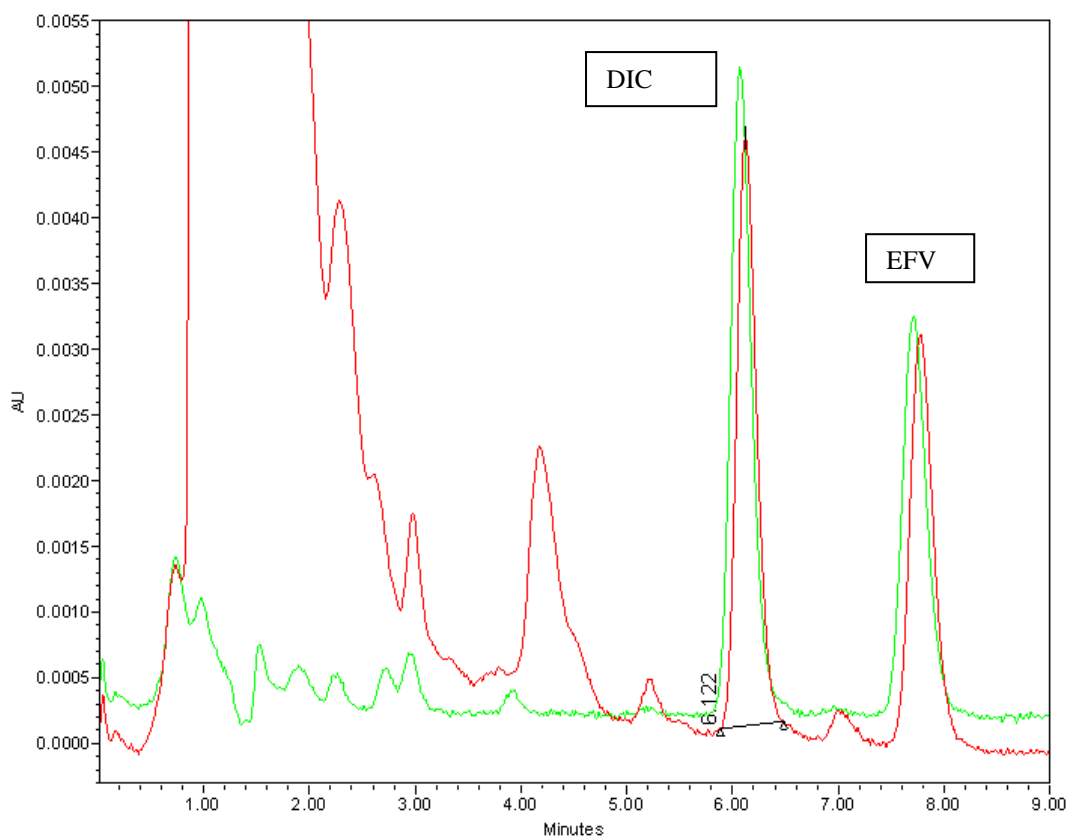

Figure 4.10. EFV at mid QC and IS in mobile phase solution (green) and plasma samples spiked with EFV at mid QC and IS (red) monitored at $\lambda=247\text{nm}$.

4.4.3.11.4 Precision

Intra-day and inter-day precision are shown in Tables 4.9 and 4.10, respectively. Precision of EFV determinations were better than 7% RSD across the entire QC concentration range.

Table 4.9. Intra-day Precision.

QC	Mean (n=5) calculated standard concentration \pm standard deviation ($\mu\text{g/ml}$)	Nominal standard concentration ($\mu\text{g/ml}$)	RSD (%)
Low	0.3298 \pm 0.0076	0.2958	2.3
Medium	1.5429 \pm 0.0449	1.4946	2.9
High	7.6153 \pm 0.1612	7.3987	2.1

Table 4.10. Inter-day Precision.

QC	Day	Mean (n=5) Nominal concentration ($\mu\text{g/ml}$)	Mean (n=5) calculated standard concentration ($\mu\text{g/ml}$)	RSD (%)
Low	1	0.2958	0.3298 \pm 0.0076	2.3
	2	0.3133	0.3060 \pm 0.0135	4.4
	3	0.3172	0.3416 \pm 0.0321	6.8
Medium	1	1.4946	1.5429 \pm 0.0449	2.9
	2	1.5619	1.5314 \pm 0.0605	3.9
	3	1.5787	1.6145 \pm 0.0226	1.4
High	1	7.3987	7.6153 \pm 0.1612	2.1
	2	7.8371	7.9353 \pm 0.1750	2.2
	3	7.9368	8.4532 \pm 0.1488	1.8

4.4.3.11.5 Lower Limit of Quantification (LLOQ)

The LLOQ was found to be 0.2 $\mu\text{g/ml}$, and the average accuracy was 115.5% with % RSD of 2.1%, and detector response more than five times the blank.

4.4.3.11.6 Linearity

An un-weighted regression analysis was used to measure linearity, and the linearity parameters are shown in Table 4.11. The %RSD value of the slopes was 2.3.

Table 4.11. Calibration linearity.

DAY	Slope	Y-intercept	Correlation coefficient r^2
Day 1	0.2107	0.0126	0.9999
Day 2	0.2205	0.0088	0.9994
Day 3	0.2144	0.0180	0.9999

4.4.3.11.7 Stability

The stock solutions were found to be stable with RSD values less than 5% at both temperatures during the relevant periods of investigations.

For the short-term stability, the difference between the two sets of samples were within 15% of each other, and within 15% of nominal values (Table 4.12), thus EFV was found to be stable when stored on the bench-top for six hours.

Table 4.12. Short-term stability of unprocessed samples.

SET	QC	Mean (n=3) calculated standard concentration (µg/ml)	Mean % of Nominal concentration	RSD (%)
ONE	Low	0.3100	91.4	3.5
	Medium	1.5542	100.4	5.0
	High	7.7705	97.3	4.4
TWO	Low	0.3100	89.5	3.1
	Medium	1.5542	95.7	3.8
	High	7.7705	96.6	7.8

Generally the results of the long-term stability studies depicted in Table 4.13 indicate that plasma samples of EFV remained stable for up to 60 days. However, the mean % nominal concentration of the low QC samples was found to be out of specification (Table 4.17). This was due to one of the replicate samples which produced an unexpectedly high result outside of the low QC concentration range. The respective sample chromatogram was revisited and inspected, and it was noticed that the peak area of the IS appeared to be unusually high. This was thus considered to be an outlier and in view of the fact that the longer term stability samples at Days 30 and 60 were all shown to be stable, stability of the low QC samples was not re-investigated.

Table 4.13. Long term stability of EFV in plasma.

QC*	Day 7			Day 30			Day 60		
	Nominal conc**. (µg/ml)	Mean % nominal conc.	RSD (%)	Nominal conc. (µg/ml)	Mean % nominal conc.	RSD (%)	Nominal conc. (µg/ml)	Mean % nominal conc.	RSD (%)
Low	0.3111	116.8	6.7	0.3082	93.4	7.4	0.3133	109.3	7.2
Med	1.5745	99.9	1.5	1.5390	84.5	1.1	1.5612	98.3	7.3
High	7.8853	100.6	12.6	7.6994	95.5	8.9	7.8553	99.4	4.4

Notes:

* n = 3, **conc. - concentration

EFV was stable under all short-term conditions studied as shown in Table 4.14.

Table 4.14. Short-term stability of the samples.

Stability sample	Sets	QC	Mean (n=3) nominal concentration (µg/ml)	% of Nominal concentration at end of run	RSD (%)
Freeze thaw	SET ONE	Low	0.3095	90.2	4.7
		Medium	1.5466	98.7	11.3
		High	7.7434	97.2	4.8
	SET TWO	Low	0.3095	98.1	3.1
		Medium	1.5466	98.8	5.0
		High	7.7434	107.9	5.7
On-instrument	Low	0.3095	98.7	4.9	
	Medium	1.5466	100.9	4.9	
	High	7.7434	101.0	5.8	
Re-injection	Low	0.3095	94.8	2.2	
	Medium	1.5466	102.1	6.1	
	High	7.7434	107.2	1.7	

4.4.3.12 Conclusions

A cost-effective HPLC-UV method was developed which is simple, rapid, precise, accurate and repeatable, and thus applicable for the quantitative analysis of EFV in human plasma. Separation between EFV and IS was achieved with a C₁₈ column, and the run time was less than 9 min. The mobile phase optimisation and detection by dual wavelengths resulted in well resolved peaks, and permitted the use of lower concentrations of the IS. EFV was found to be stable in the mobile phase for one week. A simple protein precipitation method using readily-available solvents yielded excellent recoveries for EFV, with increased sensitivity. The assay performance data show that the method meets the requirements of a suitable bioanalytical method which can be applied for the analysis of samples for pharmacokinetic studies.

Previous methods utilized various organic modifiers and/or ion pairing reagents at relatively high pH (> 10 and greater), or even complicated and time consuming gradient elution. The mobile phase used in this study, consisted of a simple mixture of a low concentration of formic acid (0.1 M) solution, together with acetonitrile and a small amount of methanol (5%) at a pH of 2.2. This system is cost-effective and in addition provides protection of the silica column stationary phase from high pH damage thereby ensuring that the column life is not shortened.

CHAPTER 5

***IN VIVO* INTERACTIONS BETWEEN EFAVIRENZ AND AFRICAN POTATO (*Hypoxis hemerocallidea*)**

5 Introduction

Clinical studies aimed at assessment of drug interactions are pivotal to the characterisation of new drug molecules, as well as evaluating safety of medications used concomitantly in clinical practice. Clinical drug interaction studies are now rationally designed because of recent scientific developments in the areas of pharmacokinetics and pharmacodynamics. Prior to designing a clinical drug interaction study, researchers have to consider a number of factors, such as the physico-chemical properties of the substrate and the interacting drug, duration of use of the substrate and the interacting drug, metabolic pathways, and *in vitro* data. This is important because the substrate drug and the interacting drug may share a common metabolic pathway, and may be found to interact *in vitro* but this does not necessarily imply that a clinically-significant interaction will occur. A clinically-significant interaction is one which leads to a change in the therapeutic and/or toxicity of a drug such that the dose of the drug has to be adjusted, and/or frequency of administration or a medical intervention will be necessary [229].

In recent years, better understanding of the role and mechanisms of CYP450 enzymes has resulted in the development of methods for the determination of effects of drugs on the enzymes *in vitro*. However, the data from *in vitro* studies are usually used qualitatively. An evaluation of the data submitted to the U.S.A. Food and Drug Administration revealed that there are limitations caused by unpredictability of *in vivo* drug interactions from *in vitro* data [230]. The uncertainties in predicting *in vivo* drug interactions from *in vitro* data are a result of it not being possible to determine the concentration available to the enzyme in the liver [64]. Some proposals to use surrogate *in vivo* concentrations that could be used to extrapolate *in vitro* results have been suggested. However, there is still a need to confirm positive *in vitro* interaction results using *in vivo* studies. The use of *in vitro* induction data has also been discussed during the recent review of the FDA guidance on *in vivo* drug metabolism/interactions studies, and so far, there are no consistent criteria for determining whether a clinical drug-drug interaction study should be conducted [231]. For inhibition

studies, it has been proposed that *in vivo* studies should be conducted if *in vitro* data show an $[I]/K_i > 0.1$, where $[I]$ is the mean maximum plasma concentration (C_{max}) value of the total drug (bound and unbound) at the steady state of the highest clinically-used dose, and K_i is the inhibition constant [232]. This, however, cannot be applied to TMs/CAMs since the clinical doses for most of these medicines have not yet been determined, and most of the TMs/CAMs do not exist as single compounds. Further limitations of predicting *in vivo* TM-drug interactions from *in vitro* data include variability of composition of the TMs/CAMs products, and lack of knowledge of hepatic concentrations, bioavailability, metabolism and extent of plasma protein binding of the product/constituents.

As mentioned in Chapter 1, drug interactions may occur between orthodox medicines and TM/CAMs. An *in vitro* drug interaction study using recombinant P₄₅₀ enzymes on effects of AP, hypoxoside and rooperol, showed that these products are inhibitors of CYP3A4, A5 and 19 [88]. Because of the use of AP by patients on HAART, it is necessary to assess the effect of AP on EFV which is the backbone of HAART. EFV is metabolised by CYP3A4 and CYP2B6. Therefore there is a possibility of a drug interaction between EFV and AP. AP may reduce metabolism of EFV, resulting in high plasma concentrations of EFV. The high plasma concentrations of EFV could lead to increased risk of adverse events which could also lead to reduced adherence to treatment and ultimately treatment failure. Therefore, the objective of this project was to design a clinical study and evaluate the effect of African Potato (AP) on the pharmacokinetics of EFV in human volunteers.

5.1 Clinical Trial Design

The design of a clinical trial depends on the objective/s of the study, which should be determined at the planning stage [233]. Clinical studies can be classified as parallel or crossover. A crossover trial is when patients receive two or more treatments, and a parallel design is when each patient receives only one treatment. During planning, the design of the study must establish various factors and requirements such as objectives, factors (in an efficacy trial the drugs are factors to be evaluated), types of responses, and sample size, amongst others.

5.1.1 Parallel Design

For a parallel study design, an equal number of patients are given treatment A, and another group is given treatment B. The results of the two groups are compared, and the number of treatments may be more than two. It is important to have an equal number of patients in both groups so that the standard deviation is minimised, hence the statistical power of the study is at its maximum. Randomisation is important so that it becomes a matter of chance which subjects receive a given treatment. In this case, it is assumed that the average effect of a given drug will be the same, regardless of which randomly selected group of patients happen to receive it [233]. This type of study is suitable for clinical trials where carry-over effects cannot be controlled or eliminated.

5.1.2 Cross-over Designs

In a cross-over study design, each subject is exposed to two treatments under investigation on different occasions. In this design, each patient acts as his or her own control, and can be used to evaluate within subject variability. It allows for direct comparison of treatments, and is more relevant in the presence of large inter-individual variation.

Treatments are administered on two occasions, and these are often called legs, periods or visits, and the order of treatment may be randomised to reduce period effects. A period effect is where a difference in response is due to the occasion on which the treatment is given, independent of the effect due to the treatment. This is considered as a statistical interaction or “differential carry-over” which may occur in the cross-over design. This carryover effect occurs when the response of the second period is dependent on the response of the first period, and this dependency differs, depending on the sequence of treatment. In this case a sufficiently long washout period should be employed to avoid the carryover effect. The possibility of period effects increases if the order is not balanced. Intra-subject variability is usually smaller in these designs, hence, it is more precise than parallel designs. One disadvantage of the cross-over design is that it may not be suitable when carry-over effects and other interaction effects are anticipated, hence, a parallel design is preferable. The other disadvantage of a cross-over design is that it may take longer time to complete.

5.2 Drug Interaction Study Designs

Drug interaction studies are usually conducted during phase 1 clinical trial, i.e., during the development stage of a new drug, and can also be conducted after market authorisation is granted by assessing retrospective data obtained during clinical use. The studies may be open-labelled, unless pharmacodynamic end-points are part of the assessment. Open-labelled studies are studies where both the subjects and researchers know which treatment is being administered. Clinical drug interaction studies are usually of a randomised, cross-over or one sequence cross-over or parallel design, with appropriate washout periods. The following study designs to investigate drug-interactions are used in the pharmaceutical industry [234]:

- single dose substrate drug and single dose CYP₄₅₀ enzyme probe administered in combination, and each compound given alone in a three-way cross-over study
- single dose CYP₄₅₀ enzyme probe followed by multiple dose substrate drug co-administered with single dose CYP₄₅₀ enzyme probe, or single dose substrate drug followed by multiple dose interacting drug co-administered with single dose substrate drug in a sequential two-way cross-over
- multiple dose CYP₄₅₀ enzyme probe and multiple dose substrate drug in one three-way cross-over or two two-way cross-over trial.

5.2.1 Study Population and Sample Size

Generally, clinical drug interaction studies are performed using healthy volunteers drawn from the general population, and this is based on the assumption that results from healthy volunteers should predict findings in the patient population [235]. Patients can be used if there are undue risks on healthy volunteers. When a drug interaction involves enzymes which exhibit polymorphism, then genotyping of the volunteers to identify polymorphs is important to assist interpretation of the results because a drug interaction may only occur in slow metabolisers. The number of volunteers should be adequate to assess differences, thus the power of the study should be adequate.

5.2.2 Washout Period

The washout period is the time between two doses of the same drug during a clinical study, and should be adequate to allow complete elimination of the drug, and is based on the half-

life of the drug. The recommended washout period should be based on more than five (5) half-lives of the drug [236].

5.3 Analysis of Pharmacokinetic Data

5.3.1 Pharmacokinetic Analysis

Drug interactions in which the pharmacokinetics of the substrate drug is affected are assessed using pharmacokinetic data of the substrate drug. Clinical significance of an interaction depends on the dose/concentration and concentration/response relationships for both desirable and undesirable drug effects in the general population or in specific populations. Therefore, knowledge of the relationship between dose, blood levels and response may guide the use and interpretation of particular pharmacokinetic parameters [235]. Measures of systemic absorption are used to assess the effect on the pharmacokinetics of the substrate drug. If the clinical outcome is related to the peak concentration, then maximum concentration (C_{max}) may be more appropriate than area under the curve (AUC). Other parameters, e.g., clearance (Cl), volume of distribution (V_d), half-life ($t_{1/2}$) and time to reach maximum concentration (T_{max}), are usually reported, but their results alone cannot be used to assess the occurrence of drug interactions. If studies are conducted at steady-state, then an additional measure, such as trough concentration (C_{min}) is reported to demonstrate that the dosing strategies were sufficient to attain near steady-state conditions before and during the study.

The arithmetic means AUC from the ln-transformed data of the time-concentration profile of the substrate drug are compared to assess effect of interacting drug on bioavailability of the substrate drug. The AUC may be determined up to the last sampling time of the study (AUC_t), or truncated at a particular time point and/or the AUC extrapolated to the time infinity (AUC_{∞}). The use of a truncated AUC has been proposed where some limitations, which include limited assay sensitivity and long plasma half-lives of some drugs, exist [237-241]. Nevertheless, caution has been placed on the use of truncated AUC for drugs with long half-lives [242], and that AUC can only be truncated provided that absorption has been completed, and must be truncated at 72 hr.

5.3.2 Statistical Analysis

Statistical methods used in a drug interaction study must be predetermined at the planning stage, and must be stated “*a priori*” in the protocol. The choice of a statistical method

depends on, amongst others, whether the analysis is qualitative or quantitative, and whether one is looking for relationships or differences. There are various different statistical methods for the comparison of two groups, or three or more groups, including comparison of pharmacokinetic parameters from the two periods. Measurement of bioequivalence can be used to assess the presence or absence of an interaction. Two types of statistical methods, namely, parametric and non-parametric methods, may be used to assess difference or similarity of pharmacokinetic parameters in drug interaction studies.

Parametric methods involve manipulation of data that can be assumed to derive from normal distributions [243]. An assumption has to be made that the data is normally distributed. Assumptions made before applying the parametric methods are called parametric assumptions. These assumptions are necessary to ensure that reliable and informed hypothesis testing and other procedures are carried out. The assumptions and their definitions are shown in Table 5.1.

Table 5.1. Definitions of parametric assumptions.

Assumption	Definition
Additivity	Effects of the factors are additive
Normality	Data and errors are normally distributed
Homoscedasticity	Errors e.g. standard deviations, of the data even when they come from different populations are the same
Independence	Errors of data from two or more distributions are independent of random variables. In difference tests and similar single-statistic tests, the differences are assumed to come from a single population difference

These assumptions can be tested for violations and where violations, have been made, there are remedies designed by statisticians to ensure reliability of the data. The parametric methods commonly used are t-tests and analysis of variance (ANOVA). The t-test is used to compare two means of two treatments only, thus can be used for drug interaction studies including comparison of two independent samples, e.g., means from a parallel study. ANOVA is conceivably the most robust statistical tool, and is designed to analyse data from studies whose objective is to compare two or more means. ANOVA can be applied to data from cross-over studies, provided that an assumption that, carry-over effects are absent. This is a critical assumption for correct interpretation of the results.

In instances where parametric assumptions are violated, non-parametric tests are employed. These methods assume that period or sequence (carry-over) effects are absent, and no

adjustments are made for these effects. Data for use in the non-parametric tests have to be ranked or ordered, and must have a continuous distribution. The two non-parametric tests which can be used to assess equivalence are the Wilcoxon signed rank test, and the Mann-Whitney U-test. These are alternatives to the t-test from parametric tests, the latter being the alternative to the independent t-test because it compares means from two independent groups. The Friedman test is another non-parametric test which is applied to data in the form of a two-way ANOVA design. In this test the two groups are ranked within each person or subject, disregarding differences between subjects. Other tests which have been used in drug interaction studies are Chi-squared test which is an alternative to one-way ANOVA [244], and Fischer's test which is an alternative of unpaired t-test. Non-parametric tests have been shown to be consistently less powerful than parametric tests [245], and the FDA requires justification of their use in bioequivalence assessment [236].

In drug interaction studies, the inter-changeability concept of bioequivalence can be applied because administration of one drug alone or in combination with another may or may not result in dose adjustment. Therefore, drug-drug interactions may be handled as an equivalence problem [246], using confidence intervals of the ratios of the means of relevant pharmacokinetic parameters. It has been proposed that when analysing drug interaction study data using the bioequivalence limits where the null hypothesis "no relevant interaction present" cannot be rejected, a clinically relevant interaction may only be reported if the power of the study is sufficient to avoid false positive signal [247]. According to the FDA guidance on conducting drug interaction studies *in vivo*, a no drug interaction conclusion is reached if the 90% confidence intervals of the geometric means of the AUC and C_{max} fall exactly within 80 -125% limit [235]. However, the European Agency for the Evaluation of Medical Products [229] in its similar guidance, allows for narrowing or widening of these limits, depending on the therapeutic consequences of the drug interaction.

In some cases, specific "no effect" boundaries or clinical equivalence intervals may be used instead of the bioequivalence model [235]. A survey conducted by the FDA on the quality and quantity of drug-drug interaction studies submitted to the agency between 1995 and 1996 showed that 30% of submissions included the more relevant equivalent approach with 90% confidence intervals for key pharmacokinetic parameters [248].

5.4 Methods and Procedures

5.4.1 Ethical and Institutional Review

The study protocol (See annexure I) was approved by the Rhodes University Ethical Standards Committee (RUESC) [249] before commencement.

The study was conducted in accordance with the recommendations of the guidelines as set out in the Declaration of Helsinki (1964) and its subsequent amendments [250], according to ICH Good Clinical Practice (GCP) guidelines [251], standard operating procedures (SOPs).

5.4.2 Study Population

An advert approved by the RUESC was posted around the university campus and various places in Grahamstown. Interested respondents were invited for a talk about the study in which the reasons for the study and study performance were explained. All participants were taken through the volunteer information brochure, and attendance was recorded. The respondents who were still interested in participating in the study were given 24 hr to read the informed consent forms and the volunteer information brochure. Signed informed consent forms were filed in the study folder and a copy was given to each volunteer.

Ten healthy male subjects who were non-smokers and HIV negative were enrolled into the study after giving informed consent. The demographics of the ten volunteers are shown in Table 5.2. The eligibility criteria (Table 5.3) included the ages between 18 and 55 years, and a body mass index (BMI) between 19 and 30 kg/m². Pre-study medical screening was performed within a month of initiating the study and volunteers who passed the physical, medical and laboratory screening tests according to the stated inclusion and exclusion criteria, were enrolled. Laboratory tests included tests for liver function, hepatitis B and C, HIV as well as blood biochemistry, urinalysis and drugs of abuse. The latter included tests for amphetamines, barbiturates, benzodiazepines, cocaine, methamphetamine, morphine, phencyclidine, THC, and TCA and volunteers were required to abstain from alcohol consumption prior to the study.

Table 5.2. Demographic data of volunteers.

	Age (yrs)	Race	Weight (Kg)	Height (m)	BMI
Subject 1	22	Black	58.2	1.675	20.74
Subject 2	23	Black	79.4	1.750	25.93
Subject 3	22	Black	77.2	1.880	21.84
Subject 4	22	White	67.2	1.860	19.42
Subject 5	23	Black	67.2	1.67	24.10
Subject 6	27	Black	66.0	1.83	19.82
Subject 7	25	Black	72.2	1.80	22.28
Subject 8	19	Black	84.0	1.82	25.50
Subject 9	23	Black	64.2	1.81	19.71
Subject 10	24	Black	87.4	1.77	27.90
Mean	22.91		71.8	1.78	22.55
Min	19		58.2	1.67	19.42
Max	27		87.4	1.88	27.90

Prescription and over-the-counter medicines were restricted from 1 week before each phase, until the last blood sample had been taken at the end of the study. Consumption of alcohol was forbidden from 4 days before the study, and caffeine and grapefruit juice were restricted from 48 hr before the study. In addition, volunteers were prohibited from strenuous exercise from 24 hr before the study.

Table 5.3. Inclusion and selection criteria.

Criteria		
Inclusion criteria	1.	Mentally competent subjects who are available for the entire study period and willing to adhere to the protocol requirements and able to give informed consent by signing the informed consent form.
	2.	Males between ages 18 and 55 years of age.
	3.	Volunteers with a BMI of between 19 and 30.
	4.	Non-smoking volunteers who have not smoked for at least two months.
	5.	Normal in terms of medical history at the pre-study screening medical, or in the case of an abnormality, if the medical practitioner considers the abnormality to be clinically non-significant.
	6.	Normal in terms of physical examination at the pre-study screening medical, or in the case of an abnormality, if the medical practitioner considers the abnormality to be clinically non-significant.
	7.	Normal in terms of laboratory test values for the pre-study screening medical within the laboratory's stated normal range, or in the case of an abnormality, if the medical practitioner considers the abnormality to be clinically significant.
	8.	Mentally competent subjects who are available for the entire study period and willing to adhere to the protocol requirements and able to give informed consent by signing the informed consent form.
Exclusion criteria	1.	Any history of hypersensitivity or idiosyncratic reaction to EFV or AP.
	2.	Any history of cardiovascular abnormality or disease.
	3.	Any history of liver dysfunction.
	4.	Any history of anaemia or cytopenia.
	5.	Any history of renal dysfunction.
	6.	Any history of adrenal or pituitary insufficiency.
	7.	Any history of chronic asthma, bronchitis or other bronchospastic conditions.
	8.	Any history of epilepsy or other convulsive disorders.
	9.	Any history of psychiatric disorders including depression or mania.
	10.	Any history or other condition which the study physician regards as clinically significant to the study (including fainting upon blood sampling).
	11.	Any history of drug or alcohol abuse or other use of tobacco within two months of the study start date.
	12.	Treatment with any drug known to have a well-defined potential for toxicity to one of the major organs, particularly renal and hepatic toxicity, within three months of the study start date.
	13.	Treatment with any drug which could modify renal excretion of drugs (e.g. probenecid) within one month of the study start date.
	14.	The intake of a restricted or abnormal diet for longer than a week within 4 weeks of the study start date.
	15.	Maintenance therapy with any drug or regular use of chronic medication.
	16.	A major illness considered to be clinically significant by the study physician within 3 months of the study start date.
	17.	Participation in another study or the donation of one pint or more of blood within 1 month of the study start date.
	18.	A positive test for Hepatitis B surface antigen, Hepatitis C or HIV.

Criteria		
Exclusion criteria	19.	Treatment with any prescription drug within one week of the study start date, unless the drug is considered to be clinically insignificant by the study physician.
	20.	Treatment with any Over The Counter (OTC) drug within one week of the study start date, unless the drug is considered to be clinically insignificant by the study physician.
	21.	The consumption of alcohol or other enzyme inducing agents within 96 hours of the start date (all barbiturates, corticosteroids, phenylhydantoin etc.).
	22.	Any vomiting or diarrhoea within 24 hours of dosing.
	23.	A positive urine test for any drug of abuse tested for at the pre-study screening medical or at check-in.

5.4.3 Study Design

A single dose, two phase sequential study was conducted in healthy male volunteers under fasting conditions. The study was divided into two phases, phase 1 which started on day 1 and phase 2 which started on day 29, each phase lasting for three days. The washout period between the administrations of the EFV doses was 28 days. The night before the study (Day 0) volunteers were checked into the clinic and tested for drugs of abuse and alcohol consumption, as well as being questioned to ensure that they complied with the study restrictions (Table 5.4). Volunteers fasted for 10 hr before they were administered a 600 mg EFV tablet followed with a 240 ml glass of water. A mouth and hand check were conducted to confirm that the dose had been ingested and this was done by a different person from the one who had administered the dose. Subjects were seated for the first 4 hr after drug administration, and were not permitted to lie down or sleep until after 4 hr post-dose, unless this was necessary due to an adverse event. Standard meals were provided until 24 hr post-dose, and the times at which meals were commenced and ended were recorded as well as approximate amounts consumed. Ten millilitre blood samples were collected into Vacutainers[®], containing potassium EDTA as the anticoagulant, at the following time intervals; before dosing (0) and at 0.5, 1.0, 1.5, 2.0, 2.5, 3.0, 3.5, 4.0, 5.0, 6.0, 8.0, 12.0, 18.0, 24.0, 36.0 and 48 hr post-dose. Blood samples were stored in an ice-bath immediately after withdrawal and until centrifugation commenced, which was within 30 min of collection. The blood samples were centrifuged at 2800 g for 10 min at 4°C. Duplicate aliquots of harvested plasma were stored in polypropylene tubes at $-80 \pm 10^{\circ}\text{C}$ until transfer to the analytical laboratory. The tubes were labelled with study number, phase number, subject number, sample number and sampling time.

From Day 16 until Day 30 of the study, the volunteers were administered a freshly prepared traditional AP decoction at a dose of 15 mg/kg/day of hypoxoside at the same time daily for 14 consecutive days. The AP decoction was prepared and assayed for hypoxoside content prior to administration. After receiving 12 consecutive daily doses of the AP decoction, phase 2 was initiated on day 28 when each of the volunteers received a 600 mg dose of EFV in the same manner as they did at the beginning of the study. Blood samples were collected at the same time intervals as previously described in phase 1. Dropouts were not replaced.

Table 5.4. Study Restrictions.

Restricted Item	Duration of Restriction	Examples of Restriction	Comments
Prescription medicines	From 1 week before the start of the study, until the end of Phase 2 of the study	<ul style="list-style-type: none"> • All medicines obtained on prescription • Antibiotics, vaccinations • Anti-inflammatories • Antiasthmatics • Antiacne medicines 	<i>This includes all long-term medication.</i>
Over-the-Counter (OTC) medicines	From 1 week before the start of the study, until the end of Phase 2 of the study.	<ul style="list-style-type: none"> • Anti-flu medicines, sports supplements, paracetamol • Vitamins, minerals 	<i>This includes all medication that can be bought without a prescription.</i>
Caffeine	From 2 days (48 hours) before the start of each phase and during each phase until the last blood sample for that phase has been taken. No caffeine containing beverages for a total of 10 days for each phase.	<ul style="list-style-type: none"> • Drinks: coffee, tea, coke, most colas, green tea, Milo etc. • Foods: chocolate, Tonics, Bioplus 	<p><i>This includes all chocolate containing foods e.g. chocolate cake, chocolate ice cream, choc chip biscuits.</i></p> <p><i>Rooibos tea and herbal teas containing guarana are allowed.</i></p>
Alcohol	For 4 days (96 hours) before the start of each phase and during each phase until the last blood sample for that phase has been taken. No alcohol for a total of 12 days for each phase.	<ul style="list-style-type: none"> • All alcoholic drinks and alcohol containing foods. 	<i>It is very important that this requirement is taken seriously and observed, as alcohol can significantly affect the liver. Failure to comply with this requirement can seriously affect the study.</i>
Strenuous Physical Exercise	From 24 hours before the start of each phase and during each phase until the last blood sample for that phase has been taken. No strenuous exercise for a total of 9 days for each phase.	<ul style="list-style-type: none"> • Rugby • Squash • Rowing • Gym • Tennis etc. 	<i>Light exercise such as walking is permitted.</i>
Food and Fluids	For the duration of the clinic stay for each phase as well as restrictions detailed above	<ul style="list-style-type: none"> • All foods and fluids 	<i>Food and fluid intake will be standardised while you are in the clinic to minimise inter-individual variation, and will be provided for you.</i>
Grapefruit	From 2 days (48 hours) before the start of each phase and during each phase until the last blood sample for that phase has been taken.	<ul style="list-style-type: none"> • Grapefruit • Grapefruit juice 	

5.4.4 Analysis of Plasma Samples

Plasma samples were analysed according to the validated HPLC-UV method described in Chapter 4. All plasma samples were analysed within 40 days of collection, and samples for each volunteer covering both phases were analysed in one analytical batch. An analytical batch consisted of individual subject's samples (both phases), together with seven (7) calibration standards, and two sets of quality control samples at three different concentrations (0.3, 1.5 and 7.5 µg/ml). The QC samples were analysed at the beginning and at the end of each run. The peaks from the chromatograms were integrated and peak areas of EFV and diclofenac sodium (DICNa), the internal standard (IS), were used to calculate peak area ratios.

Calibration plots were constructed for each batch, and the acceptance criteria for the curve was that six of the calibration standards should be <15% of the nominal concentration, and that of the standard at the lower limit of quantitation (LLOQ) was <-20%. Upon acceptance of a calibration plot and QC samples, an un-weighted linear regression plot was generated. Concentration of EFV in plasma of subjects was determined from the linear regression equation of the calibration plot.

5.4.5 Preparation of African Potato Decoction

The AP corms used to prepare the AP decoctions were bought from a registered traditional healer based in Grahamstown. An AP decoction was freshly prepared each day according to the traditional manner. The roots on the corms were removed prior to washing with tap water. The washed corms were grated and weighed on a Mettler PM 4600 balance (Mettler Instruments AG, Zurich, Switzerland). About 200 g of the grated corm was added to 2.5 L of water, and brought to boil for about 45 min. The decoction was allowed to cool at ambient temperature. Fifteen decoctions were prepared daily in this manner and analysed accordingly.

5.4.6 Analysis of AP Decoction

The quality of AP corms can be quite variable, hence standardisation of each decoction preparation was necessary. The AP decoction was analysed using an HPLC-UV method (Nair

2006). Two samples of the prepared decoction was analysed, and the concentration of hypoxoside in the decoction was determined.

5.4.7 Dosing of AP Decoction

The dose of AP decoction was standardised according to the hypoxoside content, which was used as the QC marker. Each volunteer received the equivalent of 15 mg/kg/day of hypoxoside in the form of the decoction. The choice of the hypoxoside dose was based on published hypoxoside safety data. The toxicity of hypoxoside was previously assessed in patients with lung cancer at doses ranging from 1200 to 3200 mg daily, and the compound was found to be safe throughout the dosage range [193]. More recently, a single dose toxicity study performed in mice and assessed over a period of 48 hr indicated that the lethal dose was found to be 1948 ± 57 mg/kg [181]. A further study was subsequently reported where similar results were found following a single dose to mice and followed for 14 days [170]. Even though these studies are considered to provide inadequate information of the mitigation of risk for human participants in clinical studies, they do provide an indication of AP toxicity/safety. Therefore, the 15 mg/kg/day dose of hypoxoside was considered safe to use in healthy, human volunteers.

5.4.8 Data Analysis

5.4.8.1 Pharmacokinetic Analysis

The pharmacokinetic parameters of EFV before and after co-administration with AP were determined using a non-compartmental model [252]. Exposure measures such as area under the curve (AUC) of the plasma concentration-time profiles from 0 hr to 48 hr (AUC_{0-48}), and peak plasma EVF concentrations (C_{max}), were used to assess the effect of AP on the pharmacokinetics of EFV. Other parameters that were monitored included the elimination half-life ($t_{1/2}$), time taken to reach peak plasma concentration (t_{max}), and the elimination rate constant (k_{el}). The AUC_{0-48} and C_{max} were calculated, and the trapezoidal rule was used to estimate AUC_{0-48} .

5.4.8.2 Statistical Analysis

ANOVA was conducted on C_{\max} and AUC_{0-48} , using log-transformed data, and the geometric mean ratios were calculated. The two one-sided t-test [253] was used to determine the respective 90% CIs. An interaction is concluded if the 90% CIs for C_{\max} and AUC_{0-48} are found to be outside the limits of 80 -125% [235]. ANOVA analysis was conducted using SAS[®] software (SAS Institute Inc., Cary, North Carolina, USA).

If a pre-dose concentration (carry-over) of EFV is detected in Phase 2, the subject's data are included in the statistical analysis, if it represents less than 5% of the C_{\max} value. However, if this is greater than 5% of the C_{\max} value, then the subject must be excluded from the study [236].

5.5 Results

All volunteers completed the study and there were no deviations from the study restrictions. Three volunteers experienced minor adverse events of dizziness, loss of concentration and sleepiness within 4 hr of dosing with EFV. These events subsided without any medical intervention within 2 hr of reporting. All adverse events were recorded in the case report forms.

5.5.1 AP decoction Preparations and Analyses

The concentrations of hypoxoside in the 15 AP decoctions ranged from 8.03 and 27.02 mg/ml, see Table 5.5.

5.5.2 Plasma EFV Analysis

All samples were analysed using the previously described validated HPLC-UV method (Chapter 4), and none of the samples were excluded from the pharmacokinetic analysis. A bioanalytical report is given in Annexure II. Mean plasma EFV concentrations were calculated and plotted to generate plasma EFV profiles (Figure 5.1). The profiles are virtually super-imposable during the early stages of the absorption phase, as well as later during the elimination phase, but differences were apparent around the C_{\max} .

Table 5.5. Linearity of hypoxoside calibration curve and concentrations of AP decoction.

DAY	Y – intercept	Gradient of calibration curve	Correlation coefficient	Concentration of AP decoction (µg/ml)
1	-0.1507	0.0444	0.9981	10.16
2	-0.14	0.481	0.9955	8.03
3	-0.2497	0.0515	0.9979	16.60
4	-0.1749	0.0440	0.9939	18.21
5	-0.0592	0.0350	0.9839	12.92
6	-0.0925	0.0423	0.9996	13.26
7	-0.173	0.0387	0.9985	19.26
8	-0.1229	0.0411	0.9992	14.97
9	-0.1116	0.0433	0.9986	15.81
10	0.0139	0.0352	0.9954	13.92
11	-0.139	0.0339	0.9962	17.92
12	-0.0292	0.0301	0.9937	27.02
13	0.1043	0.0383	0.9892	15.45
14	-0.0153	0.0363	0.9968	15.31
15	0.1275	0.0333	0.9986	21.41

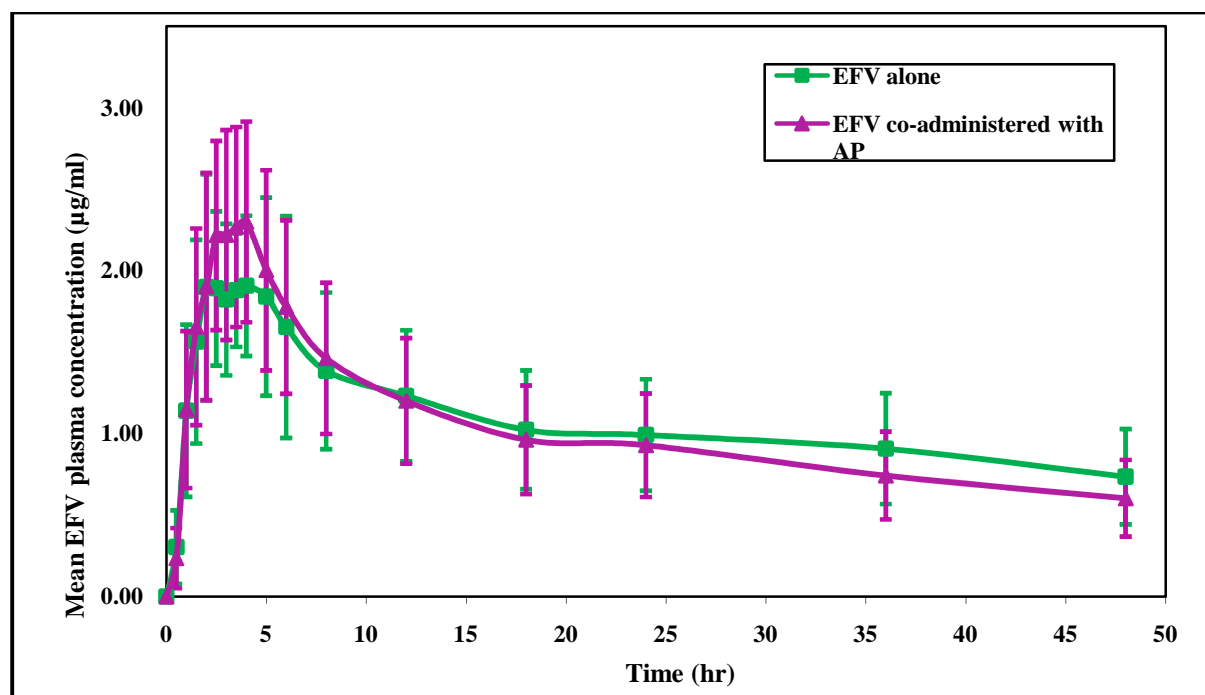

Figure 5.1. Mean and SD of plasma concentration vs time of EFV alone and EFV co-administered with AP.

5.5.3 Pharmacokinetic and Statistical Parameters

The mean T_{max} of EFV following single dose administration of a 600 mg EFV tablet alone was found to be similar to the published values of approximately within 5 hours. The mean T_{max} after co-administration with AP was approximately the same, occurring at 2.9 hours. C_{max} and AUC_{0-48} values before and after AP administration was also fairly similar, see Table 5.6.

Table 5.6. Summary of statistics of pharmacokinetic parameters and statistical analysis of EFV alone and EFV co-administered with AP.

Pharmacokinetic Parameter	EFV alone (n=10)	EFV with AP (n=10)	Ratios of geometric means (90% CI)
AUC_{0-48} ($\mu\text{g}\cdot\text{h}/\text{ml}$)			
mean	49.65	48.60	102.82 (89.04-118.80)
CV%	25.63	29.07	
C_{max} ($\mu\text{g}/\text{ml}$)			
mean	2.41	2.53	97.30 (78.81- 120.14)
CV%	16.52	26.52	
$t_{1/2}$ (h)			
mean	52.29	48.02	N/A*
CV%	43.29	36.30	
T_{max} (h)			
mean	3.10	2.90	N/A
CV%	46.75	37.95	
k			
mean	0.015	0.016	N/A
CV%	36.15	34.55	

*N/A = Not Applicable

5.6 Discussion

The C_{max} parameter, is a discontinuous variable which is known to have high variability due to the uncertainty of precisely determining it, compared to the AUC, which is a continuous variable. Furthermore, C_{max} is confounded by AUC, hence, the 90% CI set for C_{max} may have been too narrow. The point estimate of the ratio of the means of C_{max} was 97.30, which is very close to unity, and with a CV% of 25.3, an increase in the sample size is unlikely to improve the results, since the power of the study was greater than 90%, using only 10 subjects. Although the 90% CIs for C_{max} did not fall within the 80-125% interval, the acceptance limits for this parameter are generally considered to be less important than the AUC, as previously discussed, except where the clinical outcome of the drug treatment is related to peak concentration as an indicator of toxicity. The clinical outcome of EFV is related to exposure of the drug, and not the C_{max} , therefore, in this case, the use of AUC alone

as a measure of drug interaction should be adequate. It has been suggested that when setting pharmacokinetic margins for clinical significance of a drug interaction, the pharmacodynamic and efficacy data of the substrate drug should be also considered [247]. Safety of EFV was monitored during this study, and there were no adverse events reported which were linked to the administration of EFV. Therefore, the strict application of the of 80-125% interval to the C_{max} in determining an interaction is probably inappropriate. The EMEA recommends the use of AUC, Cl and bioavailability (F) for the determination of an interaction, and recommend that C_{max} may be used as a parameter for assessing drug interactions where the safety issue of the drug is dependent on its pharmacological action [229]. In the case of EFV, there is conflicting information on the correlation of its safety, and with its plasma concentrations [254-256]. Use of both point estimates as well as the CIs to form a basis of a drug interaction is recommended by the EMEA. Hence, the findings from this study suggest that interactions as a result of the co-administration of AP and EFV are unlikely.

In vitro studies have shown that hypoxoside inhibits CYP3A4 enzymes, and also induces P-gp [88]. The situation is different *in vivo* since hypoxoside is rapidly metabolised to rooperol following oral administration in humans [186], and is not absorbed *per se*. Thus, only rooperol, the hypoxoside metabolite, enters the systemic circulation where it is subsequently metabolised to form highly water soluble glucuronides and sulphates. Hence, any effect on the CYP3A4 enzymes following AP administration is unlikely to be due to hypoxoside. On the other hand, the effective metabolism of rooperol may result in low concentrations of this metabolite in the blood after oral consumption of AP, which may be too low to significantly affect the activity of the CYP3A4 enzyme system.

Recent papers have suggested that EFV is mainly metabolised by CYP2B6, and to a lesser extent CYP3A4 [121]. Whereas hypoxoside and rooperol have been shown to affect CYP3A4 *in vitro*, and since the pharmacokinetics of EFV were not altered following co-administration of AP, components of AP probably do not affect CYP2B6 enzymes. Some other constituents of AP such as stigmaterol, however, were also found to inhibit CYP3A4 *in vitro*, but activity of stigmaterol *in vivo* did not alter the pharmacokinetics of EFV in this study.

Even though hypoxoside is not absorbed into the blood, it could still induce P-gp in the stomach and small intestine because it is only metabolised in the colon. Therefore, absorption of therapeutic agents which are substrates of P-gp, could be affected. Notwithstanding, such

an interaction is not expected to influence the plasma concentration of EFV, since EFV is not a substrate of P-gp [112].

5.7 Conclusions

The traditionally prepared AP decoction did not significantly change the AUC of EFV after single dose of EFV, but the C_{max} was outside the bioequivalence limit. The absence of adverse events related to EFV and the results from the pharmacokinetic analysis of EFV, indicated that the short-term administration of a traditionally prepared AP decoction is unlikely to affect the pharmacokinetics of EFV. There is, however a need to investigate the effect of AP on other ARVs, particularly those ARV's which are P-gp substrates, or whose major metabolic pathway is *via* CYP3A4 isozymes, particularly protease inhibitors.

CONCLUDING REMARKS

The use of TMs/CAMs brings challenges to healthcare professionals and researchers. The increase in the use of these medicines necessitates the need for further research in this area, since many of these TMs/CAMs have not been well studied. As such products become more and more commercially available; there is a need to provide evidence-based information to the public so that they can make informed choices. The use of TMs/CAMs does not only occur in parts of the world where there is poor access to orthodox medicines; it also occurs in countries where there is easy access to good primary and secondary healthcare. In all these cases, patients may use TMs/CAMs alone or in combination with orthodox medicines. The possibility of resultant pharmacokinetic and/or pharmacodynamic drug-TM interactions is thus extremely important to investigate. Therefore, the *in vitro* methods which have been applied to orthodox medicines can be readily applied to investigate the effects of TMs/CAMs on enzymatic and drug transporter mechanisms. One of the challenges with TM/CAM products is that they generally exist as complex mixtures of multi-components; hence, prior to conducting an *in vitro* study, it is important to identify a suitable analytical marker that can be used to quantitatively determine the effects of the TM/CAM on CYP enzymes and transporters. Another challenge with TMs/CAMs is that they are loosely regulated, hence, when using commercially-available unregulated products, one must be aware that the label claim may not be accurate, hence, it is important to standardise the dose when conducting a study.

Whereas data from *in vitro* studies of drug-TM interactions may in some instances suggest that interactions have occurred, confirmation of such interactions are essential, and should thus be followed up by conducting appropriate *in vivo* studies. This study, in fact, was influenced by previously reported *in vitro* data where AP was shown to interact with CYP3A4 and also induced P-gp. Guidelines developed for drug interactions of orthodox medicines may be applied to drug interactions involving the use of TMs/CAMs, since the principles of interactions are the same. In the past few years, there has been an increase in clinical studies evaluating drug-TM interactions, but only a relatively few of these medicines have been studied for possible interactions with concurrent therapy. The present study investigated the effects of concomitant administration of AP with the antiretroviral agent

EFV since this NNRTI is the backbone of HAART, and AP is commonly used concurrently with ARVs by people living with HIV/AIDS in South Africa.

A bioanalytical method for the quantitative determination of EFV in plasma was developed, validated and applied to the study samples. The method developed has significant advantages over previously reported HPLC methods, being rapid and cost-effective, as well as having the requisite accuracy, precision and sensitivity to quantitatively determine EFV in human plasma.

Changes in pharmacokinetic parameters of EFV were assessed following the administration of EFV alone, and after co-administration of EFV and traditionally prepared AP decoction to healthy human subjects. The 90% CI of the AUC and C_{max} were 89.04 -118.80 and 78.81 – 120.14% respectively, and the geometric mean ratios were 102.82 and 97.30 respectively.

AP is consumed in various preparations, and also in pharmaceutical dosage forms including traditionally-prepared decoctions. Since this study evaluated the effect of a traditionally-prepared AP decoction, these results should not be extrapolated to other AP preparations or pharmaceutical dosage forms, since those may contain other components which may, on their own, have effects on metabolism and efflux of EFV. Furthermore, administration of AP in any form needs to be standardised, and this was carried out on the freshly-prepared AP decoctions using hypoxoside as a QC marker.

Finally, future investigations should consider conducting studies on other ARVs which are metabolised mainly by CYP3A4, such as the protease inhibitors, and also perhaps, in patients on an antiretroviral treatment regimen.

ANNEXURES

- 1. Research Protocol**
- 2. Raw data of the pharmacokinetic parameters and concentrations of plasma standards, QC samples and subjects samples**

RESEARCH PROTOCOL

A SINGLE-DOSE, TWO PHASE, SEQUENTIAL DESIGN DRUG-INTERACTION STUDY OF THE EFFECT OF *Hypoxis Hemerocallidea* (AFRICAN POTATO) ON THE PHARMACOKINETICS OF EFAVIRENZ IN HEALTHY MALE VOLUNTEERS UNDER FASTING CONDITIONS

Study No. EFV/AP-01
20 July 2007

Reference Product	Stocrin[®] 600mg tablets (EFV 600mg) MSD, South Africa
Co-Administered Product	African Potato extract (15mg/kg/day Hypoxoside) Standardised AP preparation
Site	Faculty of Pharmacy Rhodes University Grahamstown, 6140 RSA.

TABLE OF CONTENTS

1. FINAL APPROVAL OF PROTOCOL	111
2. INVESTIGATORS AND FACILITIES	112
3. STUDY SUMMARY.....	113
4. BACKGROUND INFORMATION	116
4.1. EFAVIRENZ	116
4.1.1. MOLECULAR STRUCTURE	116
4.1.2. MODE OF ACTION AND USES	116
4.1.3. PHARMACOKINETIC PARAMETERS	116
4.1.4. ADVERSE EFFECTS	117
4.1.5. CONTRAINDICATIONS	117
5. STUDY DRUGS.....	117
5.1. DESCRIPTION	117
5.2. SUPPLY AND STORAGE	118
6. OBJECTIVES	118
7. STUDY DESIGN.....	119
8. STANDARDS FOR BIOEQUIVALENCE, PHARMACOKINETICS AND STATISTICS	119
8.1. STANDARDS FOR PHARMACOKINETIC EVALUATION	119
8.2. PHARMACOKINETICS AND STATISTICS	120
8.2.1. PHARMACOKINETIC ANALYSIS	120
8.2.2. STATISTICAL ANALYSIS	120
9. STUDY POPULATION AND MEDICAL ASSESSMENT	121
9.1. NUMBER OF SUBJECTS	121
9.2. INCLUSION CRITERIA	121
9.3. EXCLUSION CRITERIA	121
9.4. CONCOMITANT MEDICATION AND SUBJECT RESTRICTIONS	122
9.5. CRITERIA FOR REMOVAL FROM THE STUDY	123
10. STUDY PROCEDURE.....	123
10.1. PRE- AND POST-STUDY MEDICAL SCREENING	123
10.2. RATIONALE FOR HIV SCREENING	124

10.3.	CLINIC CHECK-IN AND CONFINEMENT	125
10.4.	PREPARATION FOR DOSING AND DOSING INSTRUCTIONS	125
10.5.	POSTURE AND PHYSICAL ACTIVITY	126
10.6.	BLOOD SAMPLING, PROCESSING AND STORAGE	126
10.7.	FASTING, REFRESHMENTS AND MEALS	126
10.8.	SUBJECT MONITORING	127
11. ETHICAL AND REGULATORY REQUIREMENTS.....		127
11.1.	ETHICAL AND INSTITUTIONAL REVIEW	127
11.2.	WRITTEN INFORMED CONSENT	127
11.3.	CASE REPORT FORMS	128
11.4.	QUALITY ASSURANCE	128
11.5.	RECORD RETENTION	128
11.6.	INSURANCE	128
11.7.	TERMINATION OF THE STUDY	128
11.8.	MONITORING OF THE STUDY	129
11.9.	ADHERENCE TO PROTOCOL	129
11.10.	BLINDING	129
11.11.	DRUG ACCOUNTABILITY	129
11.12.	ADVERSE EVENTS/ADVERSE DRUG REACTIONS	129
12. SAMPLE ANALYSIS AND STORAGE		130
12.1.	ANALYTICAL FACILITY	130
12.2.	SAMPLE STORAGE	130
12.3.	ANALYTICAL METHOD	130
12.4.	QUALITY CONTROL SAMPLES	130
12.5.	ABERRANT VALUES AND RETESTED SAMPLES	130
13. REPORTS.....		131

1. Final approval of protocol

Study Number	EFV/AP-01
Study Title	A Single-Dose, Two-Phase, SEQUENTIAL Design, Drug Interaction Study of the Effect of <i>Hypoxis hemerocallidea</i> (African Potato) on the Pharmacokinetics of Efavirenz in Healthy Male Volunteers Under Fasting Conditions
Reference Product	Stocrin[®] 600mg tablets (EFV 600mg) MSD, South Africa
Co-Administered Product	African Potato extract (15mg/kg/day Hypoxoside) Standardised African Potato (AP) preparation

<p>.....</p> <p>Principal Investigator</p> <p>Prof. I. Kanfer Faculty of Pharmacy Rhodes University</p>	<p>.....</p> <p>(dd/mm/yr)</p>
<p>.....</p> <p>Study Investigator</p> <p>Ms. Seloï Mogatle Faculty of Pharmacy Rhodes University</p>	<p>.....</p> <p>(dd/mm/yr)</p>
<p>.....</p> <p>Study Physician</p> <p>Dr. A. Koushis Peppergrove Mall African Street</p>	<p>.....</p> <p>(dd/mm/yr)</p>

2. Investigators and facilities

POSITION	NAME AND QUALIFICATIONS	CONTACT ADDRESS
PRINCIPAL INVESTIGATOR	Prof. I. Kanfer BSc (Pharm), BSc (Hons), PhD	Faculty of Pharmacy Rhodes University Grahamstown, 6140, RSA. Tel: +27-46-603-8381 Fax: +27-46-636-1205
STUDY INVESTIGATOR	S. Mogatle MPharm(Hons)	Faculty of Pharmacy Rhodes University Grahamstown, 6140, RSA. Tel: +27-46-603-8012 Fax: +27-46-636-1205
STUDY PHYSICIAN	A. Koushis MB. ChB	Peppergrove Mall African Street Grahamstown, 6140, RSA Tel: +27-46-6063-8
STUDY SITE	Prof. I. Kanfer BSc (Pharm), BSc (Hons), PhD	Faculty of Pharmacy Rhodes University Grahamstown, 6140, RSA. Tel: +27-46-603-8381 Fax: +27-46-636-1205
PATHOLOGY LABORATORY	A. Rudman MB. ChB	Drs. Du Buisson and Partners Peppergrove Mall Grahamstown 6139, RSA. Tel: +27-46-622-9757 Fax: +27-46-622-9767
ANALYTICAL FACILITY	S. Mogatle MPharm(Hons)	Faculty of Pharmacy Rhodes University Grahamstown, 6140, RSA. Tel: +27-46-603-8012 Fax: +27-46-636-1205
FINAL REPORT	Prof. I. Kanfer BSc (Pharm), BSc (Hons), PhD	Faculty of Pharmacy Rhodes University Grahamstown, 6140, RSA. Tel: +27-46-603-8381 Fax: +27-46-636-1205

3. Study Summary

Title	As Single-Dose, Two-Phase, SEQUENTIAL Design, Drug-Interaction Study of the effect of <i>Hypoxis hemerocallidea</i> (African Potato) on the Pharmacokinetics of Efavirenz in Healthy Male Volunteers under fasting conditions.	
Objective	To assess the effect of African Potato (AP) on the pharmacokinetics of Efavirenz (EFV) by comparing the single-dose pharmacokinetics of EFV before administration of African Potato and after 12 days of a daily standardised administration of AP. EFV will be administered in each phase a single dose under fasting conditions.	
Products	Reference Product	Stocrin [®] 600mg tablets (EFV 600mg) MSD, South Africa
	Co-Administered Product	African Potato extract (15mg/kg/day Hypoxoside) Standardised AP preparation
Clinical Facility	The research study will be conducted in the Biopharmaceutics Research Institute's clinic situated on the Rhodes University campus. The clinic will be staffed by the Principal Investigator, co-investigator and a registered physician in attendance. Professional nurses will be responsible for phlebotomy and subject monitoring throughout the study. The study physician will be on-site prior to and for the first four hours after administration of the first dose in each phase and thereafter will be contactable by telephone.	
Study Design	The study will be a single-dose, two-phase, SEQUENTIAL design conducted in normal healthy non-smoking male subjects. A single oral dose of EFV 600mg will be administered in the fasted state before and after the repeated administration of a standardised African Potato preparation at a dose of 15mg/kg/day of Hypoxoside. Not all subjects will necessarily be expected to begin dosing on the same day or at the same time.	
Number of Subjects	Twelve (12) subjects will be enrolled into the study. Dropouts will not be replaced. Statistical analysis will be conducted on all subjects who complete the study.	
Blinding	The study will be an open-label study and will not be blinded in any way.	
Subject characteristics	Healthy non-smoking male volunteers aged between 18 and 55 years of age with a body mass index (BMI) between 19 and 30 will be recruited.	

Pre-Study Medical Screening	Subjects will be selected according to the stated inclusion and exclusion criteria and after providing their written informed consent to participate in the study. Subjects must be healthy according to the pre-study screening medical which will include a thorough physical examination, vital signs, medical history, routine laboratory tests for haematology, blood chemistry and urinalysis, and must test negative for Hepatitis B-antigen, Hepatitis C, Human Immune deficiency Virus (HIV) and selected drugs of abuse.
Post-Study Tests	Subjects will undergo a medical screening consisting of haematology, abridged blood chemistry, and urinalysis within 48hours following completion or termination of the study. Subjects will also be re-tested for HIV infection six months after the end study.
Confinement	Subjects will check into the clinic at least 13 hours before the scheduled dosing time on the evening proceeding each study day for each phase. Subjects will be allowed to leave the clinic after the 24 hour sample but will return for each of the remaining post-dose samples.
Dosing	On Day-1 of the study (start of Phase 1), all subjects will receive a single oral dose of EFV (1 X 600mg tablet) after which blood sampling will continue for 2 days (48hours). From Day-16 subjects will take a daily dose of AP (15mg/kg/day of Hypoxoside) until Day-31 i.e. daily dose for 15 days. On Day-29 (after 13 days of administration of AP) all subjects will receive a single dose of EFV (1 X 600mg tablet) (i.e. at the start of Phase 2 on Day-29) after which blood sampling will continue for 48hours. Each dose will be taken with 240ml tap water at room temperature.
Sampling	Blood samples will be withdrawn and collected into Vacutainer® tubes containing K-EDTA prior to each dosing with EFV (0.0 hr) then at 0.5, 1.0, 1.5, 2.0, 2.5, 3.0, 3.5, 4.0, 5.0, 6.0, 8.0, 12.0, 18, 24, 36, 48 hr after dosing. A total of 17 samples will be collected from each subject for each phase. Blood samples will be stored in an ice-bath immediately after being taken until centrifugation commences. Centrifugation will commence within 30minutes of sample withdrawal. Duplicate aliquots of harvested plasma will be stored in polypropylene tubes at $-80\pm 10^{\circ}\text{C}$ until end of phase 2. Once phase two has been completed, samples will be transferred immediately to the analytical facility. The total volume of blood withdrawn from each subject, including pre- and post study blood screening, will not exceed 460ml.
Fasting	The intake of food and fluid will be standardised from check-in for each phase until the 24hour post-dose sample has been taken. Subjects will fast for at least 10hours prior to dosing with EFV and standard meals or snacks will be served at 4, 8, 12 and 24 hours after dosing. The intake of fluids will be restricted for 1 hour before dosing to 240ml 2 hours post-dose. Water will be allowed <i>ad libitum</i> 4 hours post-dose. Apart from study restrictions, subjects will be allowed to continue with their normal routine between Phases 1 and 2.
Washout Period	28 days

Sample Analysis	EFV concentrations will be determined in plasma samples using an appropriate and validated HPLC-UV assay.
Pharmacokinetic Standards	<p>Pharmacokinetic parameters of interest for statistical analysis will be C_{max}, AUC_{0-T}, $AUC_{0-\infty}$ and k_{el}. A statistically significant effect of AP on EFV pharmacokinetics will be demonstrated if:</p> <ol style="list-style-type: none"> 1. C_{max} The mean C_{max} ratio of EFV ($C_{max(after)}/C_{max(before)}$) lies outside 80-125% calculated using Ln-transformed data. 2. AUC_{0-T} The mean AUC_{0-T} ratio of EFV ($AUC_{0-T(after)}/AUC_{0-T(before)}$) lies outside 80-125% calculated using Ln-transformed data. 3. $AUC_{0-\infty}$ The mean $AUC_{0-\infty}$ ratio of EFV ($AUC_{0-\infty(after)}/AUC_{0-\infty(before)}$) lies outside 80-125% calculated using Ln-transformed data. 4. k_{el} The mean k_{el} ratio of EFV ($k_{el(after)}/k_{el(before)}$) lies outside 80-125% calculated using un-transformed data

4. BACKGROUND INFORMATION

4.1. EFAVIRENZ

4.1.1. Molecular Structure

The molecular structure of EFV is depicted below.

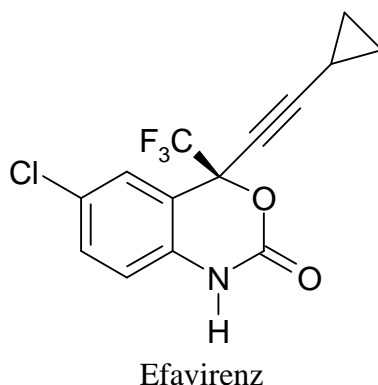

4.1.2. Mode of Action and Uses

EFV is a non-nucleoside reverse transcriptase inhibitor (NNRTI) effective against the human immunodeficiency virus type-1 (HIV-1). This activity is predominantly by non-competitive inhibition of the HIV-1 reverse transcriptase. HIV type 2 reverse transcriptase and human cellular DNA polymerase α , β , γ and δ are not inhibited by EFV¹.

4.1.3. Pharmacokinetic Parameters

The absorption of EFV from the gastro-intestinal tract is relatively slow and maximum concentrations are attained about 2-5 hours after administration in the fasted state^{1,2,3}. Co-administration of EFV with food has been shown to significantly increase both C_{max} and AUC¹. C_{max} and AUC data suggests that there is diminished absorption at higher doses over the range of 100 to 1600mg. In addition, these parameters appear to be highly variable^{1,3}.

Efavirenz is metabolised predominantly by the cytochrome P450 system (CYP 3A4 and CYP2B6) by hydroxylation and subsequent glucuronidation to inactive metabolites. Elimination is primarily by urinary excretion of metabolites and to a lesser extent by elimination of unchanged drug in the faeces. EFV has been shown to induce P450 enzymes which results in the induction of its own metabolism. This is evident by lower than expected accumulation and a shorter half-life following multiple dose administration¹.

The terminal half-life of EFV has been reported to be between 52 and 76 hours after a single dose and between 40 and 55 hours after multiple doses. Plasma protein binding is high and has been reported as 99.5-99.75%, predominantly to albumin.

¹ Package Insert, Stocrin MSD, RSA, 2006

² Veldkamp AL, Harris M, Montaner JSG et al., The Journal of Infectious Diseases, 184 (2001)37-42

³ Vilani P, Regazzi MB, Castelli F et. al., Br. J. Clin. Pharmacol., 48 (1999) 712-715

4.1.4. Adverse Effects

The majority of adverse events reported for EFV are following multiple drug therapies after varying periods of time. However, there is little reported on adverse events following single doses of EFV alone and no severe or serious adverse effects are expected following a single dose of this compound¹.

During therapy, the more serious adverse events, which present with skin rashes and psychiatric symptoms, generally occur after weeks to years of treatment. Grade 4 rashes (e.g. erythema multiforme and Steven-Johnson syndrome) have been reported. In the early stages of treatment, skin rashes are common and can occur after several days of treatment. After long-term treatment e.g. >1 year, psychiatric symptoms such as severe depression, suicidal ideation, non-fatal suicide attempts, aggressive behaviour, paranoid reaction and manic reactions have been observed. However, a history of psychiatric disorder and concurrent treatment with psychiatric medication are associated with these symptoms¹.

More common but less serious adverse events generally present with nervous system symptoms of dizziness, insomnia, impaired concentration, somnolence, abnormal dreams and hallucinations. These symptoms can begin on the first or second day of therapy, however symptoms generally resolve after 2-4 weeks of continued therapy¹.

4.1.5. Contraindications

EFV must not be administered to individuals who have an allergy to this compound or any of the tablet ingredients. EFV must be administered with caution to individuals who have a past history of psychiatric disorder and when medications for other ailments are given concurrently¹. However, in this study, volunteers taking any medications will be excluded from the study.

5. STUDY DRUGS

5.1. Description

	Reference Product	Co-Administered Product
Generic Name	Efavirenz	African Potato <i>Hypoxis hemerocallidea</i>
Commercial Name	Stocrin [®] 600mg Tablets	African Potato Extract
Dosage Form	Immediate Release Tablets	Liquid Decoction
Strength	Equivalent to 600mg Efavirenz	Equivalent to 15mg/kg/day Hypoxoside
Manufacturer	Merck Sharpe and Dohme (MSD) South Africa	Faculty of Pharmacy Rhodes University
Dosage	1 X 600mg tablet each phase	Equivalent to 15mg/kg

		Hypoxoside from Day-17 to Day-31
--	--	----------------------------------

5.2. Supply and Storage

Sufficient reference and co-administered products will be provided for the study. The quantity as well as any batch number where appropriate, will be recorded in the appropriate register. Dispensing and administration of reference and co-administered products will also be recorded.

A decoction of African Potato will be freshly prepared in the traditional manner and administered to subjects on a daily basis for 15 days. This is done by boiling African Potato in water and based on its hypoxoside content; each subject will receive an aqueous dose corresponding to 15mg/kg body weight.

Unused products will be stored for two years after the submission of the final report after which they will be disposed appropriately.

6. Objectives

The use of traditional medicine and Natural Health Products (NHPs) is widespread among people living with HIV/AIDS⁴. Many HIV/AIDS patients take a wide range of NHPs in addition to their conventional therapeutic products for HIV/AIDS as well as for related problems including dermatological, nausea, depression, insomnia and weakness. In Africa, herbal medicines are at times used as primary treatment of HIV/AIDS. The African Potato (*Hypoxis hemerocallidea*) is a common traditional medicine used in Africa by HIV/AIDS patients as an alleged immune booster and for various other conditions.

Preliminary *in vitro* studies have identified the potential for *Hypoxis hemerocallidea* to cause early inhibition of certain ARV metabolic mechanisms followed by induction of the same mechanisms after prolonged therapy⁴. Initially this can increase the risk of serious adverse events due to increased exposure to the ARV, followed later by other adverse drug events such as drug resistance due to increased exposure. Inhibition/induction of the cytochrome P450 enzyme CYP3A4 by African Potato has been implicated in this effect.

Phase 1 trials have been conducted that show that Hypoxoside is not toxic and no side effects have been reported at high doses^{4,5,6}.

⁴ Albrecht C.F., Kruger B.P, Smit B.J, Freestone M, Gouws L, Miller R, van Jaarsveld P.P, The pharmacokinetic behaviour of hypoxoside taken orally by patients with lung cancer in phase I trial, SAMJ, 85 (1995) 861-865

⁵ Albrecht C.F., Kruger B.P, Smit B.J, Freestone M, Gouws L, et. al, A phase I trial of hypoxoside as an oral prodrug for cancer therapy-absence of toxicity, SAMJ, 85 (1995) 865-870

⁶ Laporta O, Perez-Fons L, Mallavia R, Caturla N, Micol V. Isolation, characterisation and antioxidant capacity assessment of the bioactive compounds derived from *hypoxis rooperi* corm extract (African Potato). Food Chemistry. 101 (2007) 1425-1437.

Efavirenz is an ARV used widely in combination first-line therapy and is metabolised significantly by CYP2B6. The objective of this in vivo study is therefore to determine whether African Potato influences the pharmacokinetics of Efavirenz.

7. STUDY DESIGN

This drug-interaction study is designed to determine the pharmacokinetics of Efavirenz before and after co-administration with African Potato and subsequently determine the influence of African Potato on the pharmacokinetics of this ARV agent.

The study will be a single-dose, two-phase, sequential design in healthy male non-smoking volunteers which will be conducted over a period of 31 days. On Day-1 of the study (start of Phase 1), all subjects will receive a single oral dose of EFV (1 X 600mg tablet) after which blood sampling will continue for two days (48 hours). From Day-17 subjects will take a daily dose of African Potato (15mg/kg/day of Hypoxoside) until Day-31 i.e. daily for 15 days until the end of the study. On Day-29 (after 12 days of administration of African Potato) all subjects will receive a single oral dose of EFV (1 X 600mg tablet) (i.e. at the start of the Phase 2 on Day-29) after which blood sampling will continue for two days (48 hours). Each dose will be taken with 240ml of tap water at room temperature. Plasma will be harvested and assayed. Pharmacokinetics of EFV will be evaluated following each dose.

The washout period between EFV doses will be 28 days. Not all subjects will necessarily be expected to start on the same day. Data from all subjects who complete both phases will be included in the statistical analysis and the final report.

8. STANDARDS FOR BIOEQUIVALENCE, PHARMACOKINETICS AND STATISTICS

8.1. Standards for Pharmacokinetic Evaluation

Pharmacokinetic parameters for EFV before and after administration of African Potato will be determined. Statistically significant effect of African Potato on EFV pharmacokinetics will be demonstrated if:

1. C_{max} The mean C_{max} ratio of EFV ($C_{max(after)}/C_{max(before)}$) lies outside 80-125% calculated using Ln-transformed data.
2. AUC_{0-T} The mean AUC_{0-T} ratio of EFV ($AUC_{0-T(after)}/AUC_{0-T(before)}$) lies outside 80-125% calculated using Ln-transformed data.
3. $AUC_{0-\infty}$ The mean $AUC_{0-\infty}$ ratio of EFV ($AUC_{0-\infty(after)}/AUC_{0-\infty(before)}$) lies outside 80-125% calculated using Ln-transformed data.
4. k_{el} The mean k_{el} ratio of EFV ($k_{el(after)}/k_{el(before)}$) lies outside 80-125% calculated using un-transformed data.

8.2. Pharmacokinetics and Statistics

Pharmacokinetic and statistical parameters will be determined using the SAS statistical package.

8.2.1. Pharmacokinetic Analysis

EFV plasma concentration vs. time profiles will be constructed and the following pharmacokinetic parameters derived there from:

1.	C_{\max}	The maximum concentration of EFV in a subject's plasma.
2.	C_{last}	The last measurable concentration.
3.	T_{\max}	The sample time at which the C_{\max} was attained. If this occurs at more than one time point, it is identified as the first time point with this value (hour).
4.	T_{last}	The time of the last quantifiable concentration (hour).
5.	T_{lin}	The time point where log linear elimination begins (hour).
6.	AUC_{0-T}	The cumulative area under the plasma concentration vs. time curve from the time zero to the last post-dose sample at the last measurable concentration, determined using trapezoidal rule.
7.	$AUC_{0-\infty}$	The area under the extrapolated plasma concentration vs. time curve from time zero to infinity, calculated as the sum of the AUC_{0-T} and $C_{\text{last}}/k_{\text{el}}$.
8.	$AUC_{0-T/0-\infty}$	The percent ratio of AUC_{0-T} to $AUC_{0-\infty}$ as a measure of the extent to which elimination of the drug was followed.
9.	k_{el}	The apparent first-order terminal elimination rate constant calculated by linear regression of the terminal linear portion of a semi-logarithmic plot of plasma concentrations. Time using at least the last three measurable concentrations.
10.	$T_{1/2\text{el}}$	Mean elimination half-life (hour).

k_{el} , $T_{1/2\text{el}}$, $AUC_{0-\infty}$, $AUC_{0-T/0-\infty}$ and T_{lin} will not be calculated for concentration vs. time profiles that do not exhibit a terminal log-linear phase.

8.2.2. Statistical Analysis

Descriptive statistical parameters of the mean, standard deviation (SD) and coefficient of variation (CV%), will be calculated for the demographic variables of age, height, weight and Body Mass Index (BMI). These statistical parameters will also be calculated for plasma concentrations at each individual time point as well as for the pharmacokinetic parameters listed in Section 8.2.1. In addition to the descriptive statistics described above, ANOVA analysis will be conducted for additional information. These analyses will be conducted on C_{\max} , AUC_{0-T} , and $AUC_{0-\infty}$ using ln-transformed data and on T_{\max} and k_{el} using untransformed data. If a pharmacokinetic parameter of a subject cannot be determined for one period, the subject will be excluded from that particular statistical comparison.

If a pre-dose concentration of EFV is detected in Phase 2, the subject's data can be included in the statistical analysis, without adjustment, if it represents less than 5% of the C_{\max} value.

If this is greater than 5% of the C_{max} value, the subject will be dropped from the evaluations of pharmacokinetic changes.

9. STUDY POPULATION AND MEDICAL ASSESSMENT

9.1. Number of Subjects

As an initial investigation the effect of African Potato on the pharmacokinetics of EFV, 12 subjects will be enrolled. Dropouts will not be replaced. All subjects who complete the study will be included in the statistical analysis as detailed in Section 8.2.2.

9.2. Inclusion Criteria

Only subjects meeting the following criteria may be included in the study:

1.	Mentally competent subjects who are available for the entire study period and willing to adhere to the protocol requirements and able to give informed consent by signing the informed consent form.
2.	Males between ages 18 and 55 years of age.
3.	Volunteers with a BMI of between 19 and 30.
4.	Non-smoking volunteers who have not smoked for at least two months.
5.	Normal in terms of medical history at the pre-study screening medical, or in the case of an abnormality, if the medical practitioner considers the abnormality to be clinically significant.
6.	Normal in terms of physical examination at the pre-study screening medical, or in the case of an abnormality, if the medical practitioner considers the abnormality to be clinically significant.
7.	Normal in terms of laboratory test values for the pre-study screening medical within the laboratory's stated normal range, or in the case of an abnormality, if the medical practitioner considers the abnormality to be clinically significant.

9.3. Exclusion Criteria

1.	Any history of hypersensitivity or idiosyncratic reaction to EFV or AP.
2.	Any history of cardiovascular abnormality or disease.
3.	Any history of liver dysfunction.
4.	Any history of anaemia or cytopenia.
5.	Any history of renal dysfunction.
6.	Any history of adrenal or pituitary insufficiency.
7.	Any history of chronic asthma, bronchitis or other bronchospastic conditions.
8.	Any history of epilepsy or other convulsive disorders.
9.	Any history of psychiatric disorders including depression or mania.
10.	Any history or other condition which the study physician regards as clinically significant to the study (including fainting upon blood sampling).

11.	Any history of drug or alcohol abuse or other use of tobacco within two months of the study start date.
12.	Treatment with any drug known to have a well-defined potential for toxicity to one of the major organs, particularly renal and hepatic toxicity, within three months of the study start date.
13.	Treatment with any drug which could modify renal excretion of drugs (e.g. probenecid) within one month of the study start date.
14.	The intake of a restricted or abnormal diet for longer than a week within 4 weeks of the study start date.
15.	Maintenance therapy with any drug or regular use of chronic medication.
16.	A major illness considered to be clinically significant by the study physician within 3 months of the study start date.
17.	Participation in another study or the donation of one pint or more of blood within 1 month of the study start date.
18.	A positive test for Hepatitis B surface antigen, Hepatitis C or HIV.
19.	Treatment with any prescription drug within one week of the study start date, unless the drug is considered to be clinically insignificant by the study physician.
20.	Treatment with any Over The Counter (OTC) drug within one week of the study start date, unless the drug is considered to be clinically insignificant by the study physician.
21.	The consumption of alcohol or other enzyme inducing agents within 96 hours of the start date (all barbiturates, corticosteroids, phenylhydantoins etc.).
22.	Any vomiting or diarrhoea within 24 hours of dosing.
23.	A positive urine test for any drug of abuse tested for at the pre-study screening medical or at check-in.

9.4. Concomitant Medication and Subject Restrictions

1.	Medication	No prescription medication or OTC medication (cold preparations, vitamins, complementary medicines or natural products used for therapeutic benefits, antacids) will be allowed for at least one week prior to the study. Any medication taken between the screening medical and dosing will be assessed for its effect on the study and subjects may be excluded if necessary. With exception of study drugs no concomitant medication may be taken by subjects during the study.
2.	Alcohol	No alcohol may be taken by subjects from 96 hours prior to dosing until the last sample of each phase has been taken and after Phase 2 until the post-study clinical investigations have been completed.
3.	Caffeine	No caffeine containing beverages and foods (e.g. tea, coffee, cola drinks, and chocolate) may be taken by subjects from 48hours before dosing until the last sample of each phase has been taken.
4.	Exercise	No strenuous physical activity may be undertaken by subjects from 24 hours before each phase until the last sample of Phase 1 has been taken and

		until the post study clinical investigations after phase two have been completed.
5.	Smoking	Subjects must not have smoked for at least 2 months prior to the study and will refrain from smoking until the end of the second phase after the last sample has been withdrawn.
6.	Grapefruit	No grapefruit juice may be consumed within 48 hours before each phase and until the end of each phase.

Subjects will be informed of the above restrictions and each subject will be specifically questioned on these points prior to drug administration. Any deviations from the above restrictions which are made known to the investigators either voluntarily or on questioning will be recorded on the appropriate Case Report Form (CRF). A decision as to whether the affected subject continues with the study will be taken by the Principal Investigator in consultation with the Co-Investigator.

9.5. Criteria for removal from the Study

Any subject may withdraw voluntarily due to any reason.

In addition, any subject may be withdrawn from the study at any time due to:

1. Illness or injury during the study if regarded as clinically significant by the study physician.
2. Any adverse event or signs of toxicity if regarded as clinically significant by the study physician.
3. Failure of the subject to comply with or be uncooperative towards any study requirements if regarded as clinically significant by the study physician.
4. If it is determined that the subject did not follow pre-study directions regarding alcohol, drug use, fasting etc. the study physician or the Principal Investigator can remove the subject from the study.

A post-study medical will be conducted on any subject who withdraws from the study and any follow-up procedures where necessary. Reasons for a subject's withdrawal will be documented in the subject's CRF and in the final study report. Blood concentration data of a subject who withdraws due to drug adverse reaction will be presented in the final report. However, this data will not be presented for a subject who withdraws voluntarily or is removed from the study due reasons other than an adverse event.

10. STUDY PROCEDURE

10.1. Pre- and Post-Study Medical Screening

Pre- and post-study evaluations will be conducted as listed in the table below.

Pre-study screening will be conducted not more than 30 days prior to the start of Phase 1. Post study screening will be conducted within 48 hours of the final sample of Phase 2 or termination of the study.

Screening Test	Pre-Study	Post-Study
Medical History	Yes ¹	Yes ⁸
Physical Examination	Yes ²	No
Haematology	Yes ³	Yes ³
Blood Chemistry	Yes ⁴	Yes ⁹
Urinalysis	Yes ⁵	Yes ⁵
Serology	Yes ⁶	Yes ^{10,12}
Drugs-of-Abuse	Yes ⁷	no

Yesⁿ – tests conducted as per footnote # “n”, No- Tests not conducted.

1. Medical History: Demographic data (date of birth, age, sex, origin), emotional (psychiatric), cns, ears-eye-nose-throat, cardiovascular, respiratory, hepatic, gastrointestinal, renal, genitourinary, endocrine, metabolic, musculoskeletal, skin (dermatological), connective tissue and blood lymphatic illness, allergies, blood donation, alcohol consumption, smoking habits and sporting commitments.
2. Physical: Demographic data (height, weight, BMI), vital signs (BP, pulse, oral temperature), skin, head-neck, thyroid, eyes, ears-nose-throat, chest, lungs, heart, 10 Lead ECG, neurological, musculoskeletal, abdomen, nutritional status, JACCOL (jaundice, anaemia, cyanosis, clubbing, oedema, lymphadenopathy).
3. Haematology: Haemoglobin, total and differential red blood cell count, haematocrit, total and differential white cell count, platelet count and sedimentation rate.
4. Blood Chemistry: Sodium, potassium, chloride, urea, urate, creatinine, cholesterol, random glucose, total protein, albumin, total and conjugated bilirubin, alkaline phosphates, GGT (glutamyl transpeptidase), ALT (alanine transaminase) and AST (aspartate transaminase)
5. Urinalysis: Appearance, microscopic examination if positive of sediment, glucose, ketones, blood protein, nitrite, specific gravity, pH, leucocyte esterase, bilirubin and urobilinogen.
6. Serology: Hepatitis: B S-antigen and C, HIV
7. Drugs-of-Abuse: Urine samples from each subject will be tested for methaqualone by the contracted registered pathology laboratory at the time of the pre-study screening medical. Urine samples from each subject will be tested for amphetamines, barbiturates, benzodiazepines, cocaine, methamphetamine, morphine, phencyclidine, THC, TCA, and ethyl alcohol at each check-in using test kits.
8. Medical History: Since start of Phase1.
9. Blood Chemistry: Urea, urate, alkaline phosphatase, GGT (glutamyl transpeptidase), ALT (alanine transaminase) and AST (aspartate transaminase), total and conjugated bilirubin.
10. Blood Analysis: Baseline full blood counts (FBCs) will be determined immediately prior to the first African Potato dose, weekly thereafter during the full period of African Potato dosing.
11. Histology: Peripheral blood smears for microscopy.
12. Serology: HIV 6 months after end of study

If any study related abnormalities are observed at the post-study medical, appropriate follow-up action will be taken and re-examination and re-testing conducted until the abnormality returns to normal or until the Principal Investigator considers the abnormality as clinically significant. Clinically significant abnormal laboratory values will be reported as an adverse event.

10.2. Rationale for HIV Screening

HIV screening will be conducted prior to the study and volunteers who are HIV-positive will be excluded from participation. This is necessary to prevent persons being exposed to single doses of EFV, which could result in HIV resistance to EFV and significantly compromise the individual's future treatment. However, the possibility exists that subjects enrolled into the study may have been infected with HIV at the time of screening, but were in the "window period" and not detected as HIV-positive. In addition, subjects could become infected during the study. In these cases subjects infected with HIV would inadvertently be exposed to the EFV. Appropriate modification of anti-HIV treatment would then be necessary. The duration of the window period varies from subject to subject and on the type and sensitivity of the HIV test conducted, and may be from ten days to six months. For the ELISA HIV screening tests which will be used for this study, it is generally accepted that this period is a maximum of six months. Screening at the end of the maximum window period post-study will ensure that any subject who was infected with HIV at the time of the study will be detected, although it should be noted that an HIV-positive result at this time does not necessarily mean the subject was infected during the study. All subjects who take EFV during the course of the study will therefore be screened for HIV six months post-study. The participant will undergo the standard pre- and post-counselling for this test. Furthermore, the participant will be advised to notify their own medical practitioner that they have received two single doses of EFV as this may affect their future antiretroviral therapy.

10.3. Clinic Check-in and Confinement

Subjects will undergo a brief medical examination at the check-in, inclusion and exclusion criteria check, study restriction check, and urine screening for the specified drugs of abuse.

Subjects accepted into the study will remain in the clinic from check-in until the 24 hour post-dose blood sample has been taken. Subjects will then be allowed to leave the clinic provided that there are no significant symptoms or adverse events present. Thereafter, they will return for each of the remaining samples. Dosing with EFV for each phase will be 28 days apart.

10.4. Preparation for Dosing and Dosing instructions

The study will be a single-dose, two-phase, sequential design in healthy male non-smoking volunteers which will be conducted over a period of 31 days. On Day-1 of the study (start of Phase 1), all subjects will receive a single oral dose of EFV (1 X 600mg tablet) after which blood sampling will continue for two days (48 hours). From Day-17 subjects will take a daily dose of African Potato (15mg/kg/day of Hypoxoside) until Day-31 i.e. daily for 15 days until the end of the study. On Day-29 (after 12 days of administration of African Potato) all subjects will receive a single oral dose of EFV (1 X 600 mg tablet)(i.e. at the start of the Phase 2 on Day-29) after which blood sampling will continue for two days (48 hours). Each dose will be taken with 240 ml of tap water at room temperature.

Prior to each subject's scheduled dosing time an indwelling cannula will be inserted into an arm vein and a pre-dose blood sample taken. Vital signs (blood pressure and pulse)

will be monitored. At the scheduled dosing time for each phase, subjects will receive one oral dose of EFV. Each dose will be taken with 240ml of tap water at room temperature. A mouth and hand check will be conducted to confirm that the dose has been ingested.

10.5. Posture and Physical Activity

Subjects will be seated for the first 4 hours after drug administration and will not be permitted to lie down or sleep until after 4 hours post-dose, unless this is necessary due to an adverse event. Subjects will be required to adhere to restrictions on physical activity after leaving the clinic following 24 hours post-dose sample until after the last sample has been taken.

10.6. Blood Sampling, Processing and Storage

Blood samples collected during the first 12 hours after dosing will be collected into 10ml syringes via an intravenous cannula then transferred directly into 10ml Vacutainer[®] tubes containing K-EDTA. Subsequent samples will be collected by repeat venipuncture. Samples (10ml) will be withdrawn at the time of cannulation (pre-dose, 0.0) then at the following time points:

0.5, 1.0, 1.5, 2.0, 2.5, 3.0, 3.5, 4.0, 5.0, 6.0, 8.0, 12, 18, 24, 36 and 48 hours after dosing.

A total of 17 samples will be collected from each subject for each phase.

The clinic clock time of the blood samples will be recorded and reported for each subject. Any deviation from the sampling time schedule will be recorded and reported for each subject. The total amount of blood collected from each subject over the entire period, including blood samples withdrawn for pre- and post screening test, will not be greater than 460ml.

Blood samples will be stored in an ice-bath immediately after being taken and until centrifugation commences. Centrifugation at 2800rpm for 10 minutes at 4°C will commence within 30 minutes of sampling time. Duplicate aliquots of harvested plasma will be stored in polypropylene tubes at -80 ± 10 °C until transfer to the analytical facility. The tubes will be labelled with study number, phase number, subject number, sample number and sampling time.

10.7. Fasting, Refreshments and Meals

1. Food and fluid intake will be standardised from the time subjects check-in at the clinic until the 24 hour post-dose.
2. Water will be allowed *ad libitum* until 07.00 am on the morning of dosing i.e. no water at least 1 hour before dosing. Thereafter, water will be restricted until 2 hours post dose where 240ml where 240ml will be given at the time of dosing and 240ml 2 hours after dosing.
3. The following standard xanthine free meals, snacks and refreshments (caffeine free cola)

will be provided:-

4 hours post-dose	lunch	Chicken, vegetables, salad, fruit salad, soda
8 hours post-dose	snack	Cake and soda
12 hours post dose	dinner	Pizza, salad, fruit, and soda
24 hours post dose	breakfast	Toast, juice, fruit, egg

4. Water will be permitted *ad libitum* 4 hours post-dose.

10.8. Subject Monitoring

1. The study physician will remain at the clinic from before the commencement of the dosing until 4 hours after the first dose has been administered, and be contactable by phone for the duration of the study.
2. Blood pressure and pulse will be checked just prior to dosing then after sampling at 4 and 8 hours post-dose. Additional readings will be taken if necessary.
3. Subjects will be asked open-ended questions about their health at the time of removal of each blood sample.
4. Clinic nursing staff will ensure that subjects adhere to the restrictions regarding posture, movement and the consumption of food and beverages while at the clinic.

11. ETHICAL AND REGULATORY REQUIREMENTS

11.1. Ethical and Institutional Review

Approval by the Rhodes University Ethical Standards Committee (RUESC) will be obtained before the study commences. A letter of approval and a list of committee members and their qualifications will be provided to the funding body. The original signed letter of the ethical approval will be retained.

The study will be conducted in accordance with the recommendations of the guidelines as set out in the Declaration of Helsinki (1964) and its amendments of Tokyo (1975), Venice (1983), Hong Kong (1989), Somerset West (1996) and Edinburgh (2000), according to ICH Good Clinical Practice (GCP) guidelines, BRI standard operating procedures (SOPs) and in compliance with South African regulatory authority requirements.

11.2. Written Informed Consent

Preceding the study, the nature, purpose and the risk of participating in the study will be explained to all volunteers. If volunteers desire, they will be given time to consider the information and any questions that they might have will be answered. The nature of the insurance cover will also be explained. They will also be informed that they may withdraw from the study at any time without penalty to themselves (other than a reduced remuneration) but that they must be committed to completing the study prior to their

enrolment. Subjects will receive written, detailed instructions concerning the study performance and restrictions.

11.3. Case Report Forms

All CRFs will be Quality Assured and all major events such as final acceptance of a subject adverse event and final release from the study will be signed by the Principal Investigator and a copy included in the final report if requested.

11.4. Quality Assurance

Designated personnel are responsible for maintaining quality assurance and quality control systems with written Standard Operating Procedures (SOPs) to ensure that the study is conducted and that data are generated, documented and reported in compliance with the study protocol, GCP and applicable regulatory requirements.

11.5. Record Retention

All source documents, study reports and other study documentation will be archived and retained for a period of 10 years after the completion of the study or for a longer period if required.

11.6. Insurance

The BRI will undertake to provide adequate insurance cover on behalf of the Sponsor. Insurance is in accordance with ABPI guidelines and documentation of the policy will be made available for scrutiny by the funder and volunteers at their request. A copy of the insurance certificate will be provided to the South African Medical control Council as part of application to the MCC to conduct a clinical study. The funder will not be liable in the event of negligence on the part of study subjects, investigators, employees and personnel of the BRI. The BRI will be responsible for adequate insurance cover for these events. Insurance compensation is only payable in cases where a physical disability arises as a direct result of participation in the study. Compensation is determined by the nature and severity of the physical disability as assessed by qualified medical practitioners and according to a standardised scale. A maximum of R1 000 000.00 can be paid to any one subject. Medical expenses up to R50 000.00 which result directly from participation in the study are covered by insurance.

11.7. Termination of the Study

The Faculty of Pharmacy reserves the right to terminate the study in the interests of subject welfare following consultation with the Principal Investigator. The Principal

Investigator may terminate the study at any time for scientific or corporate reasons. If the study is prematurely terminated or suspended for any reason the Principal Investigator will promptly inform the subjects, take appropriate steps as deemed necessary under the circumstances to assure the subjects and where applicable follow up with therapy and inform the regulatory authorities.

11.8. Monitoring of the Study

An external monitor will not be required for this study.

11.9. Adherence to Protocol

Excluding an emergency situation in which proper treatment is required for the protection, safety and well-being of the study subjects, the study will be conducted as described in the approved protocol and performed according to ICH and GCP guidelines. Any deviation from the protocol will be recorded and explained.

Should amendments to the protocol be required, the amendments will be documented and signed by the Principal Investigator. If a protocol amendment has an impact on the safety of subjects, such as a change in dosing regimen or additional blood draws, the amendment will be resubmitted to the Institutional Review Board for approval.

11.10. Blinding

The study will be open-label study and will not be blinded in any way.

11.11. Drug Accountability

See Section 5.2.

11.12. Adverse Events/Adverse Drug Reactions

Subjects will be questioned on their health status at check-ins for each study period, during the study period and before leaving the clinic at the end of each phase. During the study, open-ended questions will be asked. If any adverse events are reported, the study physician will monitor the adverse event, initiate appropriate treatment if require and decide whether or not to withdraw the subject from the study. Signs and symptoms of any adverse events (AEs) which occur during the study will be fully documented in the appropriate CRF.

Adverse events (which include illnesses, subjective and objective signs and symptoms that have appeared or worsened during the course of the study and significant shifts in laboratory values or vital signs) will be assessed by the study physician during and after each phase of the study to determine whether or not they are related to the investigational

products (an Adverse Drug Reaction or ADR), to the study procedure or other. The outcome of this assessment will be recoded in the appropriate CRF.

AEs classified as serious will be reported to the Principal Investigator and the Rhodes University Ethical Standards Committee.

ADRs classified as serious and unexpected will be subject to expedited reporting as detailed in the ICH E2A and E2B guidelines on Clinical Safety Data Management and Data Elements for Transmission of Individual Case Report Forms respectively. The Principal Investigator will inform the sponsor, within the time specified in the protocol, of any serious or unexpected adverse events occurring during the study. A serious adverse event initial report form and any relevant follow-up information will be sent to the Sponsor, who in turn should forward the relevant information to the appropriate ethics committee and regulatory authority. A serious adverse event will be reported within 24 hours, whilst unexpected AEs will be reported without undue delay.

Samples obtained from a subject who withdraws due to an adverse event will be assayed for EFV. The withdrawn volunteer's plasma level data will be provided in the final report but will not be included in the statistical analysis. If the volunteer is withdrawn due to pharmacokinetic reasons i.e. non or mal-absorption of the drug for reasons such as vomiting, diarrhoea or a drug dosing problem, or, if the volunteer withdraws voluntarily for personal reasons, plasma level data are not required and samples collected there from all not be analysed.

12.SAMPLE ANALYSIS AND STORAGE

12.1. Analytical Facility

Study samples will be analysed at the analytical facility detailed in Section 2.

12.2. Sample storage

Study samples will be stored at $-80 \pm 10^{\circ}\text{C}$ immediately after harvesting. These samples will be transferred to the analytical facility at the Faculty of Pharmacy, Rhodes University in dry ice and maintained at a temperature of $-10 \pm 2^{\circ}\text{C}$ until analysis.

12.3. Analytical Method

Analysis of the samples will be undertaken in the laboratories of the Faculty of Pharmacy.

12.4. Quality Control Samples

Quality control samples will be prepared and analysed according to the relevant SOP of the analytical site.

12.5. Aberrant Values and Retested Samples

Unacceptable values attributable to analytical or pharmacokinetic reasons will be re-assayed. Final concentrations will be chosen according to the analytical site's procedures. All cases of re-assay will be reported in the final report.

13. REPORTS

A full report on the clinical, analytical and statistical sections of the study will be prepared.

ANNEXURE II

RAW DATA OF PHARMACOKINETIC PARAMETERS AND COCENTRATIONS OF
STUDY PLASMA STANDARDS, QC SAMPLES AND SUBJECT SAMPLES

Table 1. Summary of batches for EFV in human plasma

Description	Extraction Date	Regression Status	Comment
Day 01 Subjects 1, 2, 3, 4	09- December-2007	Accepted	OK
Day 02 Subjects 5,8,9	10- December-2007	Accepted	OK
Day 03 Subjects 6,7	12- December-2007	Accepted	OK

Table 2. Calibration plot parameters for EFV in human Plasma

Batch date	Curve plot	slope	intercept	Correlation coefficient (r ²)
09- December-2007	1	0.26	-0.022	0.999
10- December-2007	2	0.221	-0.021	0.999
12- December-2007	3	0.218	0.001	0.999

Table 3. Inter-assay precision ad accuracy fro calibration standards for EFV in human plasma

Batch date	Analytical run number	STD A	STD B	STD C	STD D	STD E	STD F	STD G
09- December-2007	01	106.51	101.79	98.64	103.12	99.99	98.29	100.41
10- December-2007	02	117.02	108.02	103.33	99.63	96.04	98.63	100.57
12- December-2007	03	87.87	92.39	95.60	95.35	105.96	100.98	99.47
Mean		106.98	100.73	99.19	99.37	100.66	99.30	100.15
STD		19.36	7.87	3.89	3.89	4.99	1.46	0.60
%RSD		18.09	7.81	3.92	3.92	4.96	1.48	0.59
n		3	3	3	3	3	3	3

Table 3. Inter-assay precision ad accuracy fro calibration standards for quality control samples for EFV in human plasma

Batch date	Plot Number	QC A	QC B	QC C
09- December-2007	1	105.55	86.16	101.82
		113.49	87.16	93.54
10- December-2007	2	104.04	102.93	108.29
		107.72	103.10	107.84
12- December-2007	3	102.57	101.43	102.54
		96.26	103.08	102.24
MEAN		104.94	97.31	102.71
STD		5.71	8.28	5.34
%RSD		5.44	8.51	5.20

Table 5. Final concentrations for EFV in Human Plasma ($\mu\text{g/ml}$) of subjects samples

Subject	Period*	0	0.5	1	1.5	2	2.5	3	3.5	4	5	6	8	12	18	24	36	48
01	1	0.00	0.00	0.62	0.89	0.98	1.71	1.38	1.57	2.76	3.05	2.39	1.86	1.07	1.04	1.00	0.67	0.67
01	2	0.00	0.46	1.08	1.54	2.07	2.77	2.44	3.01	2.77	2.35	1.90	1.75	1.20	0.98	0.96	0.77	0.50
02	1	0.00	0.08	1.36	2.27	2.61	1.96	1.77	1.91	1.76	1.26	0.91	0.81	0.81	0.68	0.62	0.58	0.49
02	2	0.00	0.13	2.22	2.30	2.30	2.17	1.89	1.89	1.78	1.55	1.54	1.13	0.98	0.64	0.68	0.45	0.40
03	1	0.00	0.56	1.42	2.01	2.19	2.28	2.25	2.29	2.19	1.88	1.52	1.42	1.22	0.88	0.88	0.81	0.69
03	2	0.00	0.00	0.85	1.34	1.66	1.66	1.70	1.65	1.64	1.34	1.23	1.14	0.95	0.70	0.62	0.51	0.41
04	1	0.00	0.32	1.02	1.69	2.40	2.55	2.39	2.45	2.36	2.09	2.09	1.60	1.60	1.39	1.24	1.17	0.81
04	2	0.00	0.05	1.06	1.35	1.36	1.60	1.54	1.47	1.43	1.46	1.23	0.98	0.88	0.93	0.84	0.75	0.67
05	1	0.00	0.17	0.69	1.30	2.72	2.41	2.41	2.24	2.27	2.00	1.69	1.63	1.55	1.34	1.28	1.22	0.81
05	2	0.00	0.24	1.33	2.71	2.90	2.81	2.38	2.45	2.47	2.18	1.78	1.43	1.26	1.12	0.93	0.85	0.72
06	1	0.00	0.60	1.68	1.88	1.65	1.55	1.64	1.43	1.34	1.16	1.00	0.76	0.79	0.58	0.73	0.68	0.49
06	2	0.00	0.00	0.15	0.28	0.43	1.07	1.38	1.74	2.89	3.14	1.99	1.66	1.18	0.88	0.83	0.72	0.57
07	1	0.00	0.00	0.14	0.22	0.33	0.72	0.64	1.06	1.23	2.19	2.70	2.07	1.71	1.49	1.32	1.27	0.72
07	2	0.00	0.34	1.11	1.79	1.99	2.05	2.11	2.13	2.19	1.89	1.85	1.65	1.57	1.32	1.31	1.78	0.85
08	1	0.00	0.43	1.71	2.42	2.49	2.10	1.94	1.87	1.67	1.42	1.32	1.16	1.36	1.15	1.06	0.89	0.56
08	2	0.00	0.33	1.07	1.42	1.52	2.76	3.26	3.03	2.96	1.89	2.23	1.43	1.34	0.99	1.05	0.73	0.48
09	1	0.00	0.30	1.53	1.49	1.57	1.70	1.62	1.88	1.62	1.48	1.29	1.30	1.22	0.99	0.99	1.11	0.63
09	2	0.00	0.38	1.02	1.72	2.74	2.97	3.34	3.00	2.76	2.65	2.70	2.33	1.87	1.35	1.25	1.00	0.76
10	1	0.00	0.46	0.74	1.38	1.70	1.76	1.96	1.91	1.66	1.28	1.04	0.91	0.72	0.47	0.48	0.35	0.27
10	2	0.00	0.19	1.26	1.89	1.65	1.81	1.65	1.61	1.57	1.11	0.94	0.75	0.55	0.35	0.48	0.37	0.30

- *Period : 1 is for EFV administered alone and 2 for EFV co-administered with AP

Figure 1. Plasma concentration vs time profiles of 10 subjects after administration with a single dose of EFV 600 mg tablet alone and after co-administered with AP

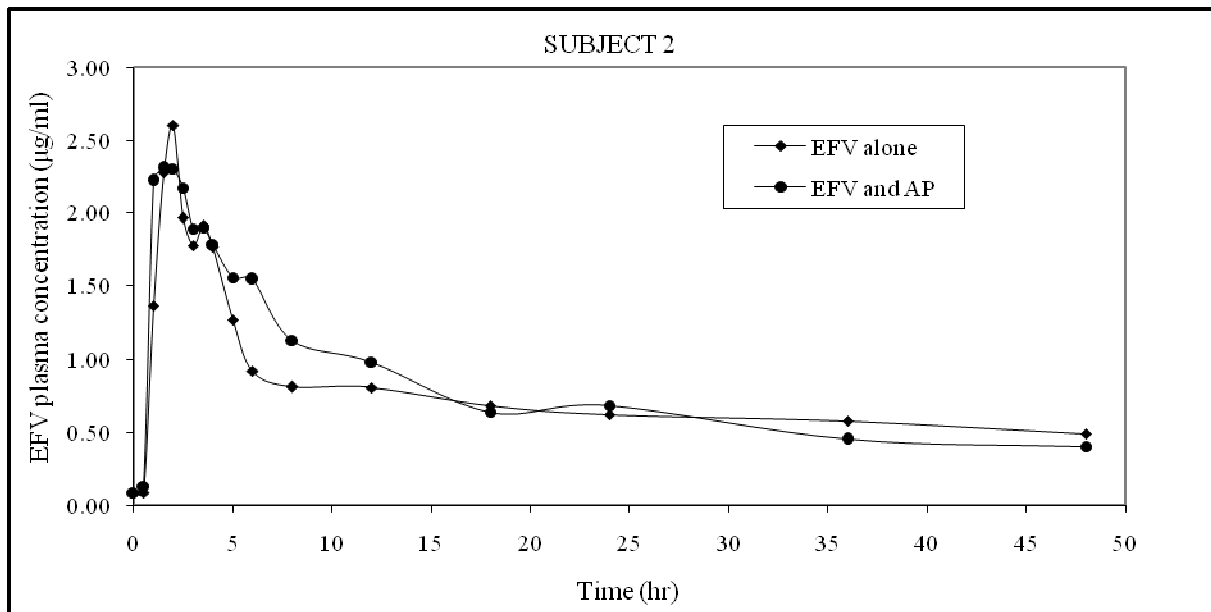
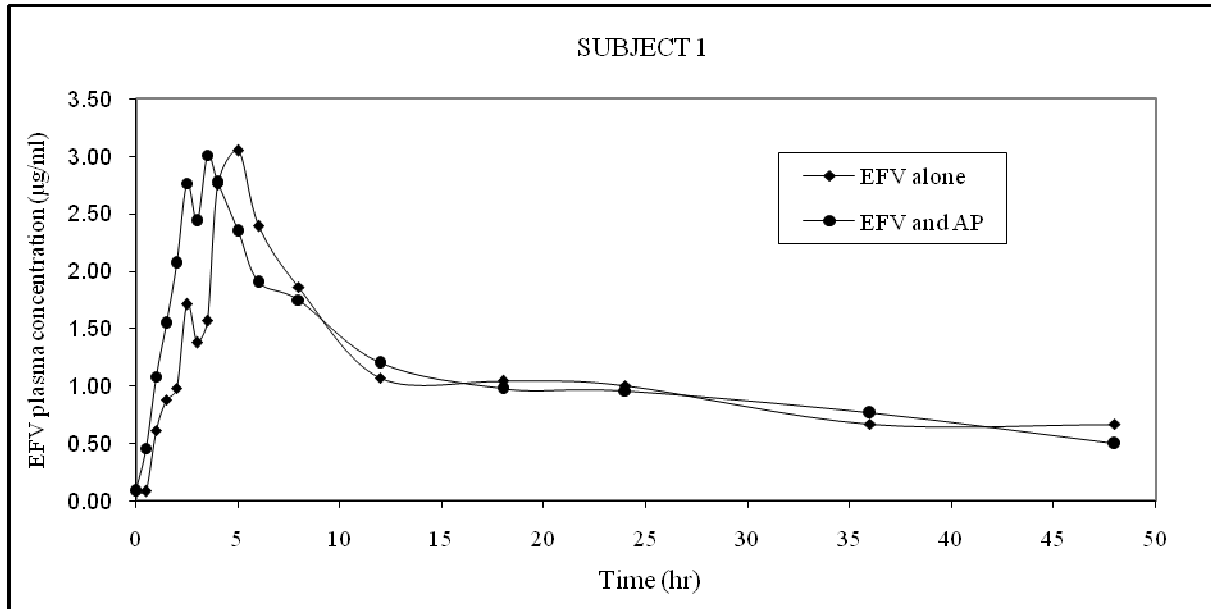

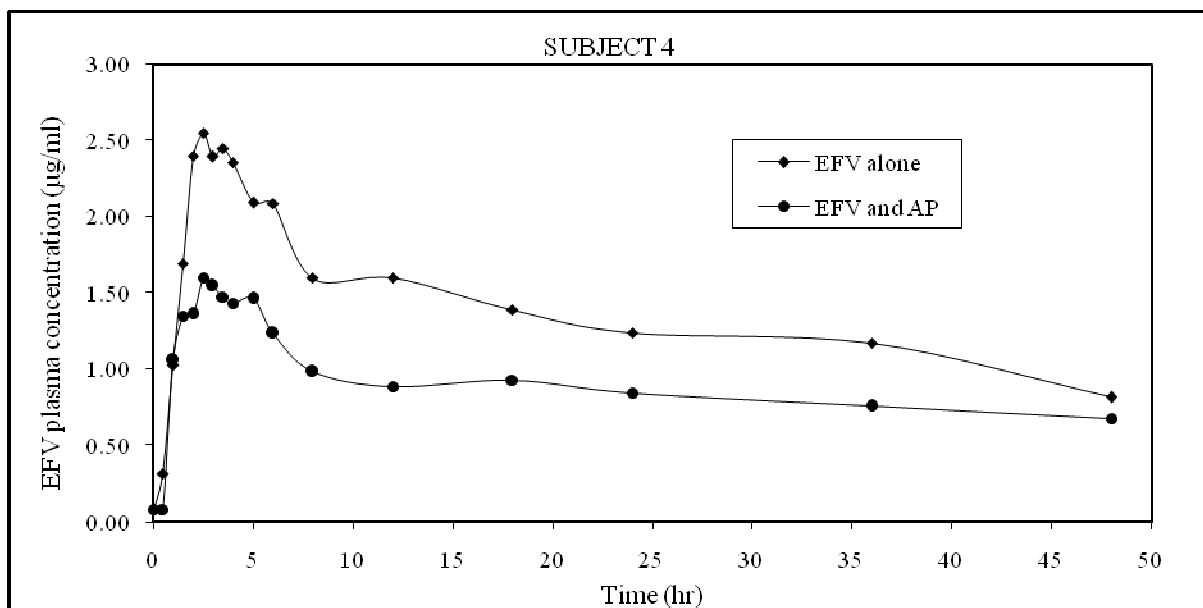
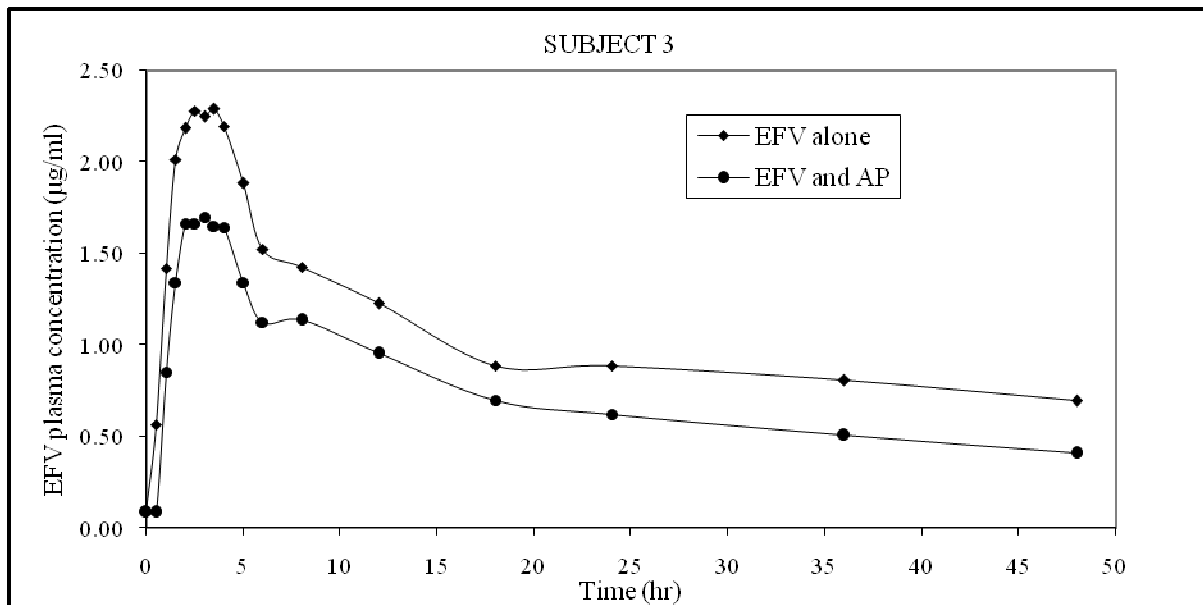

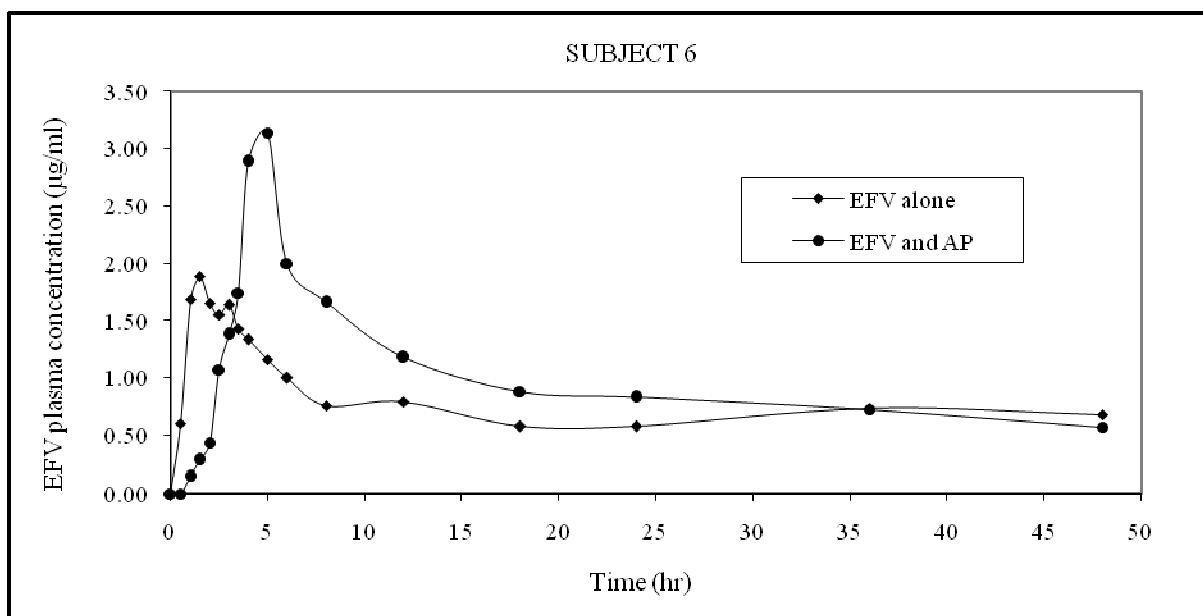
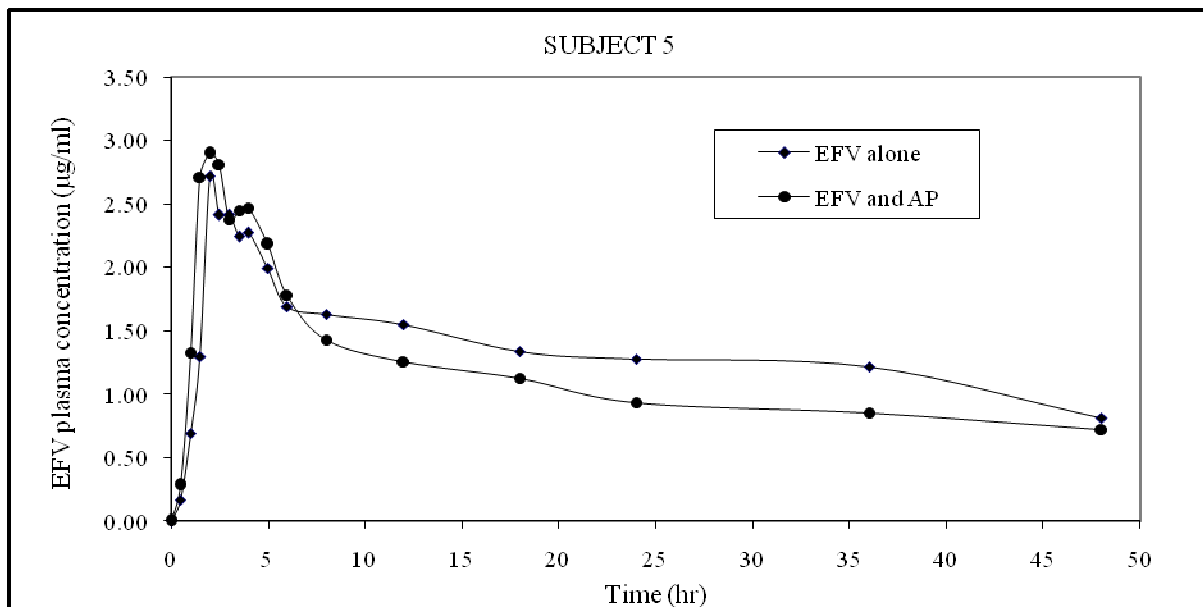

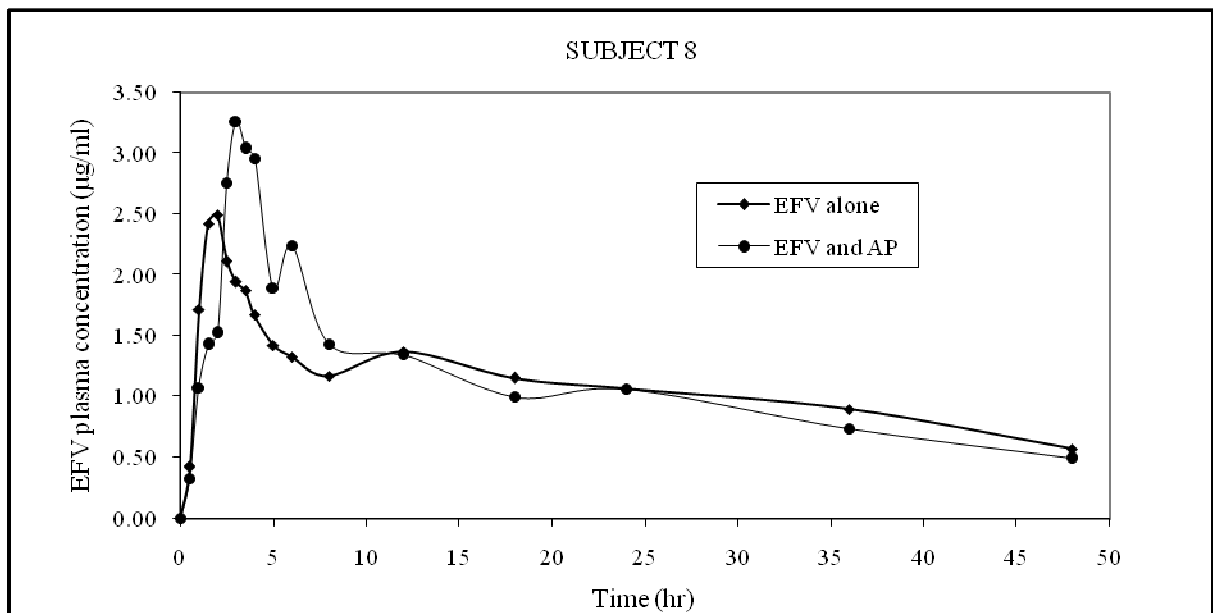
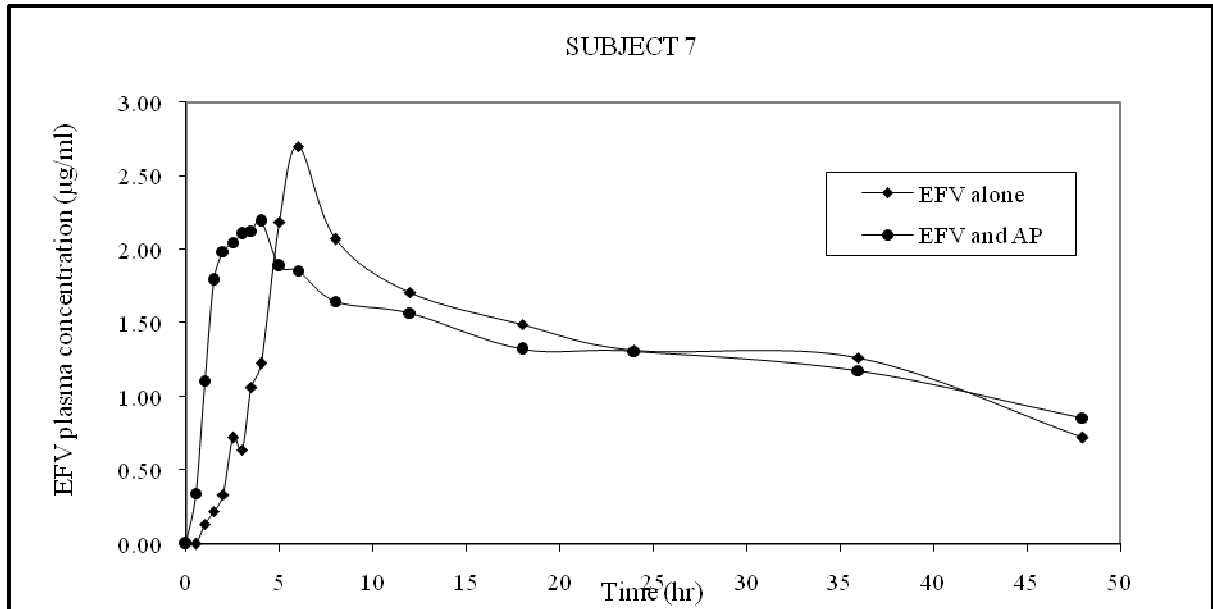

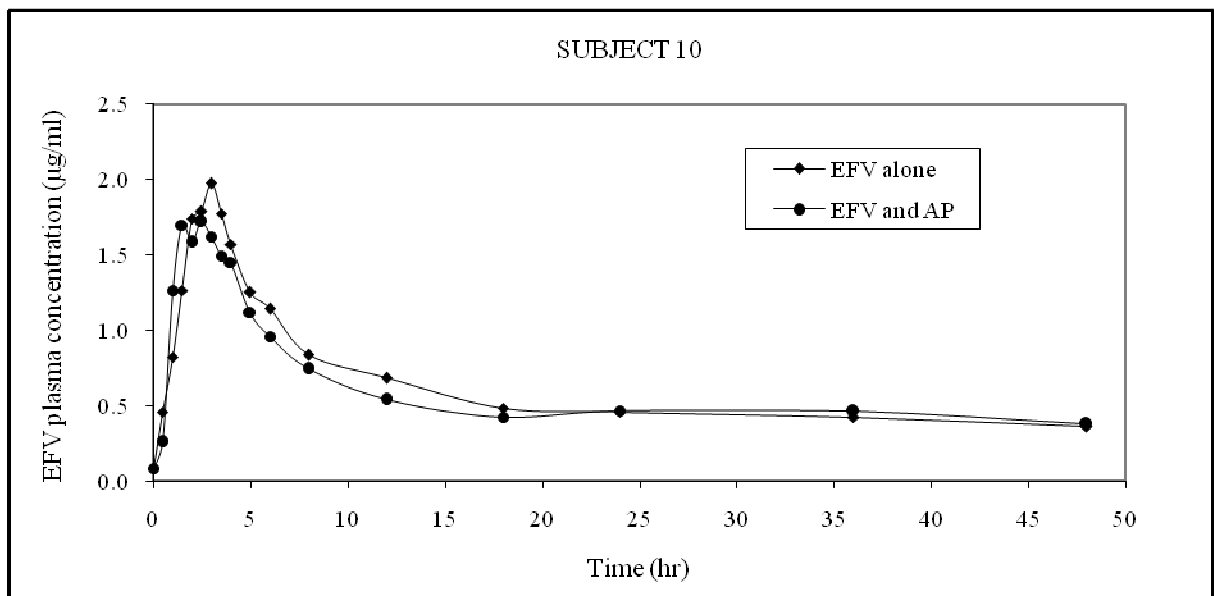
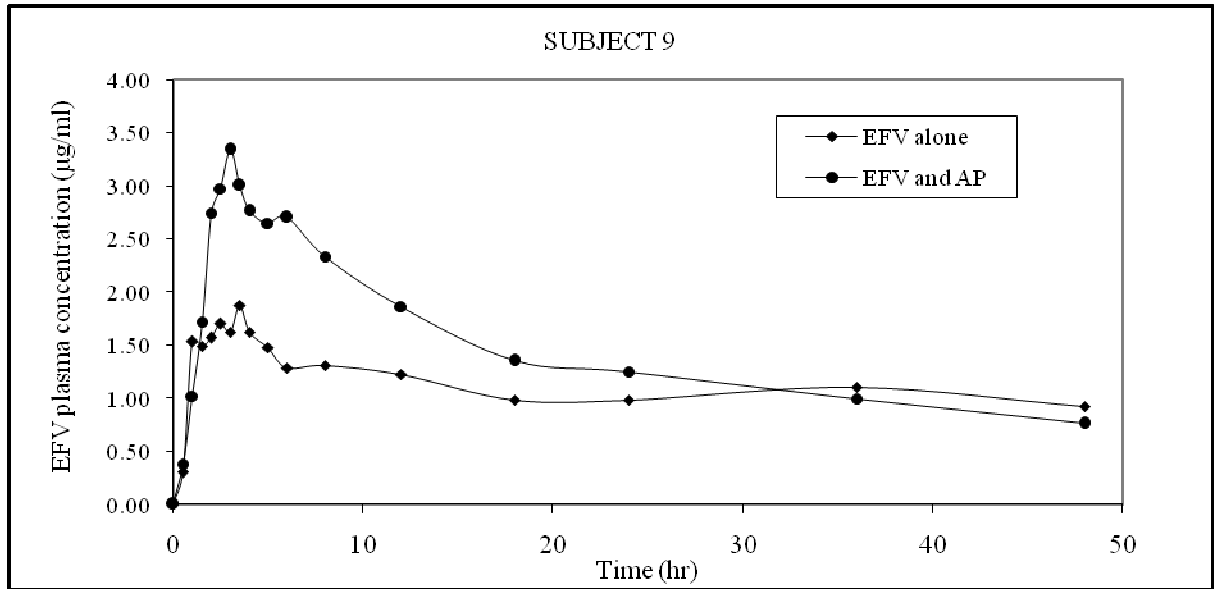

Table 6 Pharmacokinetic parameters of EFV before and after co-administration with AP

EFV administered alone							
Subject	C_{MAX}	T_{MAX}	AUC_T	AUC_∞	K_{EL}	LQCT	THALF
1	3.05	5	50.606	87.614	0.0169	48	40.94
2	2.606	2	35.871	84.295	0.0102	48	67.64
3	2.2884	3.5	49.813	134.92	0.0083	48	83.21
4	2.5473	2.5	64.533	116.62	0.0165	48	41.97
5	2.7205	2	63.872	120.24	0.0156	48	44.32
6	1.8832	1.5	36.278	111.29	0.0072	48	95.76
7	2.702	6	63.792	99.857	0.0222	48	31.18
8	2.4923	2	51.872	77.95	0.0231	48	30
9	1.8781	3.5	51.501	106.78	0.0132	48	52.59
10	1.9631	3	28.32	42.376	0.0196	48	35.3
MEAN	2.4131	3.1	49.646	98.195	0.0153	48	52.29
STD	0.3986	1.45	12.722	26.359	0.0055	0	22.64
C.V.	16.52	46.75	25.626	26.843	36.15	0	43.29
EFV co-administered with AP							
Subject	C_{MAX}	T_{MAX}	AUC_T	AUC_∞	K_{EL}	LQCT	THALF
1	3.0143	3.5	51.874	75.187	0.0228	48	30.45
2	2.3027	1.5	37.649	58.674	0.0185	48	37.49
3	1.6967	3	35.278	58.012	0.0179	48	38.79
4	1.5986	2.5	42.128	107.27	0.0103	48	67.43
5	2.8988	2	54.373	108.29	0.0133	48	51.95
6	3.1378	5	46.529	86.828	0.0145	48	47.91
7	2.1915	4	71.054	168.05	0.011	48	63.25
8	3.2629	3	52.216	72.042	0.0257	48	26.95
9	3.3394	3	68.537	108.79	0.0192	48	36.04
10	1.8945	1.5	26.384	63.436	0.0087	48	79.92
MEAN	2.5337	2.9	48.602	90.657	0.0162	48	48.02
STD	0.672	1.1	14.126	33.888	0.0056	0	17.43
C.V.	26.522	37.95	29.065	37.38	34.55	0	36.3

REFERENCES

1. Barre-Sinoussi, F., Chermann, J.C. & Rey, F. 1983, "Isolation of a T-lymphotropic retrovirus from a patient at risk for acquired immune deficiency syndrome (AIDS)", *Science*, Vol. 220, No. 4599, pp. 868-871.
2. *Report on the global HIV/AIDS epidemic 2008*: 2008, Joint United Nations Programme on HIV/AIDS, UN. Available at: http://data.unaids.org/pub/GlobalReport/2008/JC1510_2008GlobalReport_en.zip [2008, 09/15].
3. Clavel, F., Guétard, D., Brun-Vézinet, F., Chamaret, S., et al 1986, "Isolation of a new human retrovirus from West African patients with AIDS", *Science*, Vol. 233, No. 4761, pp. 343-346.
4. Shandera, W.X. 2007, "Key determinants of AIDS impact in Southern sub-Saharan Africa", *African Journal of AIDS Research*, Vol. 6, No. 3, pp. 271-286.
5. Byrn, R.A., Zhang, D., Eyre, R., McGowan, K., et al 1997, "HIV-1 in semen: An isolated virus reservoir [1]", *Lancet*, Vol. 350, No. 9085, pp. 1141.
6. Delwart, E.L., Mullins, J.I., Gupta, P., Learn Jr., G.H., et al 1998, "Human immunodeficiency virus type 1 populations in blood and semen", *Journal of Virology*, Vol. 72, No. 1, pp. 617-623.
7. *Image of HIV lifecycle*: North West Association for Biomedical Research. Available at: <http://www.nwabr.org/education/hivrequest.html> [2008, 09/17].
8. Benjamini, E., Coico, R. & Sunshine, G. (eds) 2000, *Immunology, A Short Course*, Fourth edn, Wiley-Liss, Canada.
9. Lopez, A.D., Mathers, C.D., Ezzati, M., Jamison, D.T. & Murray, C.J.L. (eds) 2006, *Global burden of disease and risk factors*, First edn, The World Bank and Oxford University Press, New York.
10. "Africa Research Bulletin, Economic, Financial and Technical Series, July 16th-August 15th 2003 Published September 11th 2003", 2003, *Africa Research Bulletin: Economic, Financial and Technical Series*, Vol. 40, No. 7, pp. 15727-15762.
11. Sukati, N.A., Mdebele, S.C., Mako, E.T., Ramukumba, T.S., et al 2005, "HIV/AIDS symptom management in Southern Africa", *Journal of Pain and Symptom Management*, Vol. 29, No. 2, pp. 185-192.

12. Sax, P.E. & Gathe Jr., J.C. 2005, "Beyond efficacy: The impact of combination antiretroviral therapy on quality of life", *AIDS Patient Care and STDs*, Vol. 19, No. 9, pp. 563-576.
13. *WHO Fact Sheet No. 134*: 2008, World Health Organisation. Available at: <http://www.who.int/mediacentre/factsheets/fs134/en/> [2008, 06/10].
14. World Health Organisation-Traditional Medicine Programme, *General guidelines for methodologies on research and evaluation of traditional medicines*: 2000. Geneva, Switzerland.
15. *Traditional medicine: definitions*: 2008, World Health Organisation. Available at: <http://www.who.int/medicines/areas/traditional/definitions/en/index.html> [2008, 06/15].
16. *The New Partnership for Africa's Development: Health Strategy*: 2008, . Available at: <http://www.nepad.org/2005/files/documents/132.pdf> [2008, 07/25].
17. Tabi, M.M., Powell, M. & Hodnicki, D. 2006, "Use of traditional healers and modern medicine in Ghana", *International nursing review*, Vol. 53, No. 1, pp. 52-58.
18. Bandeira, S.O., Gaspar, F. & Pagula, F.P. 2001, "African ethnobotany and healthcare: Emphasis on Mozambique", *Pharmaceutical Biology*, Vol. 39, No. SUPPL., pp. 70-73.
19. Thring, T.S.A. & Weitz, F.M. 2006, "Medicinal plant use in the Bredasdorp/Elim region of the Southern Overberg in the Western Cape Province of South Africa", *Journal of Ethnopharmacology*, Vol. 103, No. 2, pp. 261-275.
20. Cocks, M. & Møller, V. 2002, "Use of indigenous and indigenised medicines to enhance personal well-being: a South African case study", *Social Science & Medicine*, Vol. 54, No. 3, pp. 387-397.
21. Hirst, M.M. 1990, *The healer's art : Cape Nguni diviners in the townships of Grahamstown*, Rhodes University, Grahamstown, RSA.
22. Food Agricultural Organisation, *Marketing of Indigenous Medicinal Plants in South Africa - A Case Study in Kwazulu-Natal*: 1998. Rome, Italy.
23. Ainslie, A. 1999, "When 'community' is not enough: Managing common property natural resources in rural South Africa", *Development Southern Africa*, Vol. 16, No. 3, pp. 375-401.
24. Dold, A.P. & Cocks, M.L. 2002, "The trade in medicinal plants in the Eastern Cape Province, South Africa", *South African Journal of Science*, Vol. 98, No. 11-12, pp. 589-597.

25. Light, M.E., Sparg, S.G., Stafford, G.I. & Van Staden, J. 2005, "Riding the wave: South Africa's contribution to ethnopharmacological research over the last 25 years", *Journal of Ethnopharmacology*, Vol. 100, No. 1-2, pp. 127-130.
26. Keller, K. 1991, "Legal requirements for the use of phytopharmaceutical drugs in the Federal Republic of Germany", *Journal of Ethnopharmacology*, Vol. 32, No. 1-3, pp. 225-229.
27. Nair, V.D.P. & Kanfer, I. 2006, "High-performance liquid chromatographic method for the quantitative determination of hypoxoside in African potato (*Hypoxis hemerocallidea*) and in commercial products containing the plant material and/or its extracts", *Journal of Agricultural and Food Chemistry*, Vol. 54, No. 8, pp. 2816-2821.
28. Springfield, E.P., Eagles, P.K.F. & Scott, G. 2005, "Quality assessment of South African herbal medicines by means of HPLC fingerprinting", *Journal of Ethnopharmacology*, Vol. 101, No. 1-3, pp. 75-83.
29. Morris, K. 2002, "South Africa tests traditional medicines", *The Lancet Infectious Diseases*, Vol. 2, No. 6, pp. 319-552.
30. Freeman, M. & Motsei, M. 1992, "Planning health care in South Africa - Is there a role for traditional healers?", *Social Science and Medicine*, Vol. 34, No. 11, pp. 1183-1190.
31. Baleta, A. 1998, "South Africa to bring traditional healers into mainstream medicine.", *Lancet*, Vol. 352, No. 9127, pp. 554.
32. Bodeker, G., Kabatesi, D., King, R. & Homsy, J. 2000, "A regional task force on traditional medicine and AIDS.", *Lancet*, Vol. 355, No. 9211, pp. 1284.
33. World Health Organisation, *WHO traditional medicine strategy 2002 - 2005*: 2002. Geneva, Switzerland.
34. Cos, P., Maes, L., Vanden Berghe, D., Hermans, N., et al 2004, "Plant Substances as Anti-HIV Agents Selected According to Their Putative Mechanism of Action", *Journal of Natural Products*, Vol. 67, No. 2, pp. 284-293.
35. *Executive Board and World Health Assembly resolutions on traditional medicine*: 2008, World Health Organisation. Available at: http://www.who.int/medicines/areas/traditional/trm_assembly_doc/en/index.html [2008, 06/17].
36. *SADC Protocol on Health*: 2008, Southern African Development Community. Available at: <http://www.sadc.int/index/browse/page/152> [2008, 07/25].

37. Giraldo, G. 2003, *Southern African Development Community Ministerial Consultative Meeting on Nutrition and AIDS*.
38. Josephs, J.S., Fleishman, J.A., Gaist, P. & Gebo, K.A. 2007, "Use of complementary and alternative medicines among a multistate, multisite cohort of people living with HIV/AIDS", *HIV Medicine*, Vol. 8, No. 5, pp. 300-305.
39. Manfredi, R. & Chiodo, F. 1999, "Non-conventional treatments and HIV disease: Determining factors and consequences", *Medecine et Maladies Infectieuses*, Vol. 29, No. 2, pp. 125-129.
40. Ivers, L.C., Kendrick, D. & Doucette, K. 2005, "Efficacy of antiretroviral therapy programs in resource-poor settings: A meta-analysis of the published literature", *Clinical Infectious Diseases*, Vol. 41, No. 2, pp. 217-224.
41. *The 3 by 5 initiative*: 2008, World Health Organisation. Available at: <http://www.who.int/3by5/en/> [2008, 10/25].
42. Perez-Casas, C., Herranz, E. & Ford, N. 2001, "Pricing of drugs and donations: options for sustainable equity pricing", *Tropical Medicine & International Health*, Vol. 6, No. 11, pp. 960-964.
43. Langewitz, W., Ruttimann, S., Laifer, G., Maurer, P., et al 1994, "The integration of alternative treatment modalities in HIV infection - The patient's perspective", *Journal of Psychosomatic Research*, Vol. 38, No. 7, pp. 687-693.
44. Dhalla, S., Chan, K.J., Montaner, J.S.G. & Hogg, R.S. 2006, "Complementary and alternative medicine use in British Columbia-A survey of HIV positive people on antiretroviral therapy", *Complementary Therapies in Clinical Practice*, Vol. 12, No. 4, pp. 242-248.
45. Dahab, M., Charalambous, S., Hamilton, R., Fielding, K., et al 2008, ""That is why I stopped the ART": Patients' & providers' perspectives on barriers to and enablers of HIV treatment adherence in a South African workplace programme", *BMC Public Health*, Vol. 8.
46. World Health Organisation, *National policy on traditional medicine and regulation of herbal medicines: Report of a WHO global survey*: 2005. Geneva, Switzerland.
47. Babb, D.A., Pemba, L., Seatlanyane, P., Charalambous, S., et al 2007, "Use of traditional medicine by HIV-infected individuals in South Africa in the era of antiretroviral therapy", *Psychology, Health and Medicine*, Vol. 12, No. 3, pp. 314-320.

48. Mills, E., Foster, B.C., Van Heeswijk, R., Phillips, E., et al 2005, "Impact of African herbal medicines on antiretroviral metabolism", *AIDS*, Vol. 19, No. 1, pp. 95-97.
49. Mills, E., Montori, V.M., Wu, P., Gallicano, K., et al 2004, "Interaction of St John's wort with conventional drugs: Systematic review of clinical trials", *British Medical Journal*, Vol. 329, No. 7456, pp. 27-30.
50. Leonard, B., Huff, H., Merryweather, B., Lim, A., et al 2004, "Knowledge of safety and herb-drug interactions amongst HIV+ individuals: A focus group study", *Canadian Journal of Clinical Pharmacology*, Vol. 11, No. 2.
51. Harnett, S.M., Oosthuizen, V. & Van De Venter, M. 2005, "Anti-HIV activities of organic and aqueous extracts of *Sutherlandia frutescens* and *Lobostemon trigonus*", *Journal of Ethnopharmacology*, Vol. 96, No. 1-2, pp. 113-119.
52. Oviden, S.P.B., Yu, J., San Wan, S., Sberna, G., et al 2004, "Globoidnan A: A lignan from *Eucalyptus globoidea* inhibits HIV integrase", *Phytochemistry*, Vol. 65, No. 24, pp. 3255-3259.
53. Park, J.C., Kim, S.C., Choi, M.R., Song, S.H., et al 2005, "Anti-HIV protease activity from *Rosa* family plant extracts and rosamultin from *Rosa rugosa*", *Journal of Medicinal Food*, Vol. 8, No. 1, pp. 107-109.
54. Bessong, P.O., Obi, C.L., Andréola, M.-., Rojas, L.B., et al 2005, "Evaluation of selected South African medicinal plants for inhibitory properties against human immunodeficiency virus type 1 reverse transcriptase and integrase", *Journal of Ethnopharmacology*, Vol. 99, No. 1, pp. 83-91.
55. Martin-Facklam, M., Rieger, K., Riedel, K., Burhenne, J., et al 2004, "Undeclared exposure to St. John's Wort in hospitalized patients", *British journal of clinical pharmacology*, Vol. 58, No. 4, pp. 437-441.
56. *Research guidelines for evaluating the safety and efficacy of herbal medicines: 2008*, WHO Regional office for the Western Pacific. Available at: <http://whqlibdoc.who.int/wpro/-1993/9290611103.pdf> [2008, 06/17].
57. Schilter, B., Andersson, C., Anton, R., Constable, A., et al 2003, "Guidance for the safety assessment of botanicals and botanical preparations for use in food and food supplements", *Food and Chemical Toxicology*, Vol. 41, No. 12, pp. 1625-1649.
58. Bast, A., Chandler, R.F., Choy, P.C., Delmulle, L.M., et al 2002, "Botanical health products, positioning and requirements for effective and safe use", *Environmental Toxicology and Pharmacology*, Vol. 12, No. 4, pp. 195-211.

59. Magee, K. 2005, "Herbal therapy: a review of potential health risks and medicinal interactions", *Orthodontics & Craniofacial Research*, Vol. 8, No. 2, pp. 60-74.
60. Stewart, M.J., Moar, J.J., Steenkamp, P. & Kokot, M. 1999, "Findings in fatal cases of poisoning attributed to traditional remedies in South Africa", *Forensic Science International*, Vol. 101, No. 3, pp. 177-183.
61. Lee, L.S., Andrade, A.S.A. & Flexner, C. 2006, "Interactions between natural health products and antiretroviral drugs: Pharmacokinetic and pharmacodynamic effects", *Clinical Infectious Diseases*, Vol. 43, No. 8, pp. 1052-1059.
62. Brown, H.S., Ito, K., Galetin, A. & Houston, J.B. 2005, "Prediction of in vivo drug-drug interactions from in vitro data: impact of incorporating parallel pathways of drug elimination and inhibitor absorption rate constant", *British journal of clinical pharmacology*, Vol. 60, No. 5, pp. 508-518.
63. Butterweck, V., Derendorf, H., Gaus, W., Nahrstedt, A., et al 2004, "Pharmacokinetic herb-drug interactions: Are preventive screenings necessary and appropriate?", *Planta Medica*, Vol. 70, No. 9, pp. 784-791.
64. Obach, R.S., Walsky, R.L., Venkatakrishnan, K., Gaman, E.A., et al 2006, "The utility of in vitro cytochrome P450 inhibition data in the prediction of drug-drug interactions", *Journal of Pharmacology and Experimental Therapeutics*, Vol. 316, No. 1, pp. 336-348.
65. Venkataramanan, R., Komoroski, B. & Strom, S. 2006, "In vitro and in vivo assessment of herb drug interactions", *Life Sciences*, Vol. 78, No. 18, pp. 2105-2115.
66. Katzung, A.G. (ed) 2004, *Basic and Clinical Pharmacology*, Ninth edn, The McGraw-Gill Companies, USA.
67. Murphy, P., Kern, S., Stanczyk, F. & Westhoff, C. 2005, "Interaction of St. John's Wort with oral contraceptives: effects on the pharmacokinetics of norethindrone and ethinyl estradiol, ovarian activity and breakthrough bleeding", *Contraception*, Vol. 71, No. 6, pp. 402-408.
68. De Maat, M.M.R., Hoetelmans, R.M.W., Matho□t, R.A.A., Van Gorp, E.C.M., et al 2001, "Drug interaction between St John's wort and nevirapine", *AIDS*, Vol. 15, No. 3, pp. 420-421.
69. Smith, P. 2004, "The influence of St. John's wort on the pharmacokinetics and protein binding of imatinib mesylate", *Pharmacotherapy*, Vol. 24, No. 11, pp. 1508-1514.

70. Kawaguchi, A., Ohmori, M., Tsuruoka, S., Nishiki, K., et al 2004, "Drug interaction between St John's Wort and quazepam", *British journal of clinical pharmacology*, Vol. 58, No. 4, pp. 403-410.
71. Hebert, M.F., Park, J.M., Chen, Y.-., Akhtar, S., et al 2004, "Effects of St. John's Wort (*Hypericum perforatum*) on Tacrolimus Pharmacokinetics in Healthy Volunteers", *Journal of Clinical Pharmacology*, Vol. 44, No. 1, pp. 89-94.
72. Morimoto, T., Kotegawa, T., Tsutsumi, K., Ohtani, Y., et al 2004, "Effect of St. John's Wort on the Pharmacokinetics of Theophylline in Healthy Volunteers", *Journal of Clinical Pharmacology*, Vol. 44, No. 1, pp. 95-101.
73. Mills, E., Wilson, K., Clarke, M., Foster, B., et al 2005, "Milk thistle and indinavir: A randomized controlled pharmacokinetics study and meta-analysis", *European Journal of Clinical Pharmacology*, Vol. 61, No. 1, pp. 1-7.
74. Piscitelli, S.C., Formentini, E., Burstein, A.H., Alfaro, R., et al 2002, "Effect of milk thistle on the pharmacokinetics of indinavir in healthy volunteers", *Pharmacotherapy*, Vol. 22, No. 5, pp. 551-556.
75. DiCenzo, R., Shelton, M., Jordan, K., Koval, C., et al 2003, "Coadministration of milk thistle and indinavir in healthy subjects", *Pharmacotherapy*, Vol. 23, No. 7, pp. 866-870.
76. Piscitelli, S.C., Burstein, A.H., Welden, N., Gallicano, K.D., et al 2002, "The effect of garlic supplements on the pharmacokinetics of saquinavir", *Clinical Infectious Diseases*, Vol. 34, No. 2, pp. 234-238.
77. Kiviasto, K.T., Bookjans, G., Fromm, M.F., Griese, E., et al 1996, "Expression of CYP3A4, CYP3A5 and CYP3A7 in human duodenal tissue", *British journal of clinical pharmacology*, Vol. 42, No. 3, pp. 387-389.
78. Rodrigues, D.A. (ed) 2002, *Drug-Drug Interactions*, First edn, Marcel and Dekker, Inc., New York.
79. Juliano, R.L. & Ling, V. 1976, "A surface glycoprotein modulating drug permeability in Chinese hamster ovary cell mutants", *BBA - Biomembranes*, Vol. 455, No. 1, pp. 152-162.
80. Pal, D. & Mitra, A. 2006, "MDR- and CYP3A4-mediated drug-herbal interactions", *Life Sciences*, Vol. 78, No. 18, pp. 2131-2145.
81. Wacher, V.J., Wu, C.Y. & Benet, L.Z. 1995, "Overlapping substrate specificities and tissue distribution of cytochrome p450 3A and P-glycoprotein: Implications for drug delivery

and activity in cancer chemotherapy", *Molecular Carcinogenesis*, Vol. 13, No. 3, pp. 129-134.

82. Hall, S.D., Thummel, K.E., Watkins, P.B., Lown, K.S., et al 1999, "Molecular and physical mechanisms of first-pass extraction", *Drug Metabolism and Disposition*, Vol. 27, No. 2, pp. 161-166.

83. Ayrton, A. & Morgan, P. 2001, "Role of transport proteins in drug absorption, distribution and excretion", *Xenobiotica*, Vol. 31, No. 8-9, pp. 469-497.

84. Greiner, B., Eichelbaum, M., Fritz, P., Kreichgauer, H.P., et al 1999, "The role of intestinal P-glycoprotein in the interaction of digoxin and rifampin", *Journal of Clinical Investigation*, Vol. 104, No. 2, pp. 147-153.

85. Gurley, B.J., Swain, A., Barone, G.W., Williams, D.K., et al 2007, "Effect of goldenseal (*Hydrastis canadensis*) and kava kava (*Piper methysticum*) supplementation on digoxin pharmacokinetics in humans", *Drug Metabolism and Disposition*, Vol. 35, No. 2, pp. 240-245.

86. Ruschitzka, F., Meier, P.J., Turina, M., Lu□scher, T.F., et al 2000, "Acute heart transplant rejection due to Saint John's wort", *Lancet*, Vol. 355, No. 9203, pp. 548-549.

87. Nair, V.D.P., Dairam, A., Agbonon, A., Arnason, J.T., et al 2007, "Investigation of the antioxidant activity of African potato (*Hypoxis hemerocallidea*)", *Journal of Agricultural and Food Chemistry*, Vol. 55, No. 5, pp. 1707-1711.

88. Nair, V.D.P., Foster, B.C., Thor Arnason, J., Mills, E.J., et al 2007, "In vitro evaluation of human cytochrome P450 and P-glycoprotein-mediated metabolism of some phytochemicals in extracts and formulations of African potato", *Phytomedicine*, Vol. 14, No. 7-8, pp. 498-507.

89. Young, S.D., Britcher, S.F., Tran, L.O., Payne, L.S., et al 1995, "L-743,726 (DMP-266): A novel, highly potent nonnucleoside inhibitor of the human immunodeficiency virus type 1 reverse transcriptase", *Antimicrobial Agents and Chemotherapy*, Vol. 39, No. 12, pp. 2602-2605.

90. *The International Pharmacopoeia*: 2008, World Health Organisation - Department of EMP. Available at: <http://www.who.int/phint/en/p/docf/> [First Supplement, 09/15].

91. Maurin, M.B., Rowe, S.M., Blom, K. & Pierce, M.E. 2002, "Kinetics and mechanism of hydrolysis of efavirenz", *Pharmaceutical Research*, Vol. 19, No. 4, pp. 517-521.

92. Radesca, L. A., Maurin, M. B., Rabel, S. R. and Moore, J. R. Crystalline Efavirenz. *Patent No.* 6673372. 2004. USA.
93. Crocker, L. S., Kukura, J. L., Thompson, A. S., Stelmach, C. and Young, S. D. Crystal forms of (-)-6-chloro-4-cyclopropylethynyl-4-trifluoromethyl-1,4-dihydro-2H-3,1-benzoxazin-2-one. *Patent No.* US Patent 6939964. 2005. USA.
94. Kohlstaedt, L.A., Wang, J., Friedman, J.M., Rice, P.A., et al 1992, "Crystal structure at 3.5 Å resolution of HIV-1 reverse transcriptase complexes with an inhibitor", *Science*, Vol. 256, No. 5065, pp. 1783-1790.
95. Tachedjian, G., Moore, K.L., Goff, S.P. & Sluis-Cremer, N. 2005, "Efavirenz enhances the proteolytic processing of an HIV-1 pol polyprotein precursor and reverse transcriptase homodimer formation", *FEBS Letters*, Vol. 579, No. 2, pp. 379-384.
96. Pata, J.D., Stirtan, W.G., Goldstein, S.W. & Steitz, T.A. 2004, "Structure of HIV-1 reverse transcriptase bound to an inhibitor active against mutant reverse transcriptases resistant to other nonnucleoside inhibitors", *Proceedings of the National Academy of Sciences of the United States of America*, Vol. 101, No. 29, pp. 10548-10553.
97. Ragno, R., Frasca, S., Manetti, F., Brizzi, A., et al 2005, "HIV-reverse transcriptase inhibition: Inclusion of ligand-induced fit by cross-docking studies", *Journal of Medicinal Chemistry*, Vol. 48, No. 1, pp. 200-212.
98. Cruchaga, C., Odriozola, L., Andréola, M., Tarrago-Litvak, L., et al 2005, "Inhibition of phosphorolysis catalyzed by HIV-1 reverse transcriptase is responsible for the synergy found in combinations of 3'-azido-3'- deoxythymidine with nonnucleoside inhibitors", *Biochemistry*, Vol. 44, No. 9, pp. 3535-3546.
99. Basavapathruni, A., Vingerhoets, J., De Béthune, M.P., Chung, R., et al 2006, "Modulation of human immunodeficiency virus type 1 synergistic inhibition by reverse transcriptase mutations", *Biochemistry*, Vol. 45, No. 23, pp. 7334-7340.
100. Nunriam, P., Kuno, M., Saen-Oon, S. & Hannongbua, S. 2005, "Particular interaction between efavirenz and the HIV-1 reverse transcriptase binding site as explained by the ONIOM2 method", *Chemical Physics Letters*, Vol. 405, No. 1-3, pp. 198-202.
101. Rodríguez-Barrios, F., Balzarini, J. & Gago, F. 2005, "The molecular basis of resilience to the effect of the Lys103Asn mutation in non-nucleoside HIV-1 reverse transcriptase inhibitors studied by targeted molecular dynamics simulations", *Journal of the American Chemical Society*, Vol. 127, No. 20, pp. 7570-7578.

102. Lindberg, J., Sigurosson, S., Löwgren, S., Andersson, H.O., et al 2002, "Structural basis for the inhibitory efficacy of efavirenz (DMP-266), MSC194 and PNU142721 towards the HIV-1 RT K103N mutant", *European Journal of Biochemistry*, Vol. 269, No. 6, pp. 1670-1677.
103. Chen, R., Yokoyama, M., Sato, H., Reilly, C., et al 2005, "Human immunodeficiency virus mutagenesis during antiviral therapy: Impact of drug-resistant reverse transcriptase and nucleoside and nonnucleoside reverse transcriptase inhibitors on human immunodeficiency virus type 1 mutation frequencies", *Journal of Virology*, Vol. 79, No. 18, pp. 12045-12057.
104. Ribaud, H.J., Haas, D.W., Tierney, C., Kim, R.B., et al 2006, "Pharmacogenetics of plasma efavirenz exposure after treatment discontinuation: An adult AIDS clinical trials group study", *Clinical Infectious Diseases*, Vol. 42, No. 3, pp. 401-407.
105. Borroto-Esoda, K., Waters, J.M., Bae, A.S., Harris, J.L., et al 2007, "Baseline genotype as a predictor of virological failure to emtricitabine or stavudine in combination with didanosine and efavirenz", *AIDS Research and Human Retroviruses*, Vol. 23, No. 8, pp. 988-995.
106. Harrigan, P.R., Hogg, R.S., Dong, W.W.Y., Yip, B., et al 2005, "Predictors of HIV drug-resistance mutations in a large antiretroviral-naive cohort initiating triple antiretroviral therapy", *Journal of Infectious Diseases*, Vol. 191, No. 3, pp. 339-347.
107. Shulman, N.S., Bosch, R.J., Mellors, J.W., Albrecht, M.A., et al 2004, "Genetic correlates of efavirenz hypersusceptibility", *AIDS*, Vol. 18, No. 13, pp. 1781-1785.
108. Balani, S.K., Kauffman, L.R., Deluna, F.A. & Lin, J.H. 1999, "Nonlinear pharmacokinetics of efavirenz (DMP-266), a potent HIV-1 reverse transcriptase inhibitor, in rats and monkeys", *Drug Metabolism and Disposition*, Vol. 27, No. 1, pp. 41-45.
109. Mutlib, A.E., Chen, H., Nemeth, G.A., Markwalder, J.A., et al 1999, "Identification and characterization of efavirenz metabolites by liquid chromatography/mass spectrometry and high field NMR: Species differences in the metabolism of efavirenz", *Drug Metabolism and Disposition*, Vol. 27, No. 11, pp. 1319-1333.
110. Weiss, J., Rose, J., Storch, C.H., Ketabi-Kiyanvash, N., et al 2007, "Modulation of human BCRP (ABCG2) activity by anti-HIV drugs", *Journal of Antimicrobial Chemotherapy*, Vol. 59, No. 2, pp. 238-245.
111. Chandler, B., Almond, L., Ford, J., Owen, A., et al 2003, "The effects of protease inhibitors and nonnucleoside reverse transcriptase inhibitors on P-glycoprotein expression in peripheral blood mononuclear cells in vitro", *Journal of Acquired Immune Deficiency Syndromes*, Vol. 33, No. 5, pp. 551-556.

112. Stoermer, E., VonMoltke, L.L., Perloff, M.D. & Greenblatt, D.J. 2002, "Differential modulation of P-glycoprotein expression and activity by non-nucleoside HIV-1 reverse transcriptase inhibitors in cell culture", *Pharmaceutical Research*, Vol. 19, No. 7, pp. 1038-1045.
113. Dirson, G., Fernandez, C., Hindlet, P., Roux, F., et al 2006, "Efavirenz does not interact with the ABCB1 transporter at the blood-brain barrier", *Pharmaceutical Research*, Vol. 23, No. 7, pp. 1525-1532.
114. Berruet, N., Sentenac, S., Auchere, D., Gimenez, F., et al 2005, "Effect of efavirenz on intestinal p-glycoprotein and hepatic p450 function in rats", *Journal of Pharmacy and Pharmaceutical Sciences*, Vol. 8, No. 2, pp. 226-234.
115. Mouly, S., Lown, K.S., Kornhauser, D., Joseph, J.L., et al 2002, "Hepatic but not intestinal CYP3A4 displays dose-dependent induction by efavirenz in humans", *Clinical Pharmacology and Therapeutics*, Vol. 72, No. 1, pp. 1-9.
116. Barrett, J.S., Joshi, A.S., Chai, M., Ludden, T.M., et al 2002, "Population pharmacokinetic meta-analysis with efavirenz", *International Journal of Clinical Pharmacology and Therapeutics*, Vol. 40, No. 11, pp. 507-519.
117. Csajka, C., Marzolini, C., Fattinger, K., Décosterd, L.A., et al 2003, "Population pharmacokinetics and effects of efavirenz in patients with human immunodeficiency virus infection", *Clinical Pharmacology and Therapeutics*, Vol. 73, No. 1, pp. 20-30.
118. Almond, L.M., Hoggard, P.G., Edirisinghe, D., Khoo, S.H., et al 2005, "Intracellular and plasma pharmacokinetics of efavirenz in HIV-infected individuals", *Journal of Antimicrobial Chemotherapy*, Vol. 56, No. 4, pp. 738-744.
119. Antinori, A., Perno, C.F., Giancola, M.L., Forbici, F., et al 2005, "Efficacy of cerebrospinal fluid (CSF)-penetrating antiretroviral drugs against HIV in the neurological compartment: Different patterns of phenotypic resistance in CSF and plasma", *Clinical Infectious Diseases*, Vol. 41, No. 12, pp. 1787-1793.
120. Dupin, N., Buffet, M., Marcelin, A.G., Lamotte, C., et al 2002, "HIV and antiretroviral drug distribution in plasma and fat tissue of HIV-infected patients with lipodystrophy", *AIDS*, Vol. 16, No. 18, pp. 2419-2424.
121. Ward, B.A., Gorski, J.C., Jones, D.R., Hall, S.D., et al 2003, "The cytochrome P450 2B6 (CYP2B6) is the main catalyst of efavirenz primary and secondary metabolism: Implication for HIV/AIDS therapy and utility of efavirenz as a substrate marker of CYP2B6 catalytic activity", *Journal of Pharmacology and Experimental Therapeutics*, Vol. 306, No. 1, pp. 287-300.

122. Markwalder, J.A., Christ, D.D., Mutlib, A., Cordova, B.C., et al 2001, "Synthesis and biological activities of potential metabolites of the non-nucleoside reverse transcriptase inhibitor Efavirenz", *Bioorganic & Medicinal Chemistry Letters*, Vol. 11, No. 5, pp. 619-622.
123. Burger, D., van der Heiden, I., la Porte, C., van der Ende, M., et al 2006, "Interpatient variability in the pharmacokinetics of the HIV non-nucleoside reverse transcriptase inhibitor efavirenz: the effect of gender, race, and CYP2B6 polymorphism", *British journal of clinical pharmacology*, Vol. 61, No. 2, pp. 148-154.
124. Mehlotra, R.K., Bockarie, M.J. & Zimmerman, P.A. 2007, "CYP2B6 983T>C polymorphism is prevalent in West Africa but absent in Papua New Guinea: Implications for HIV/AIDS treatment", *British Journal of Clinical Pharmacology*, Vol. 64, No. 3, pp. 391-395.
125. Staehle, L., Moberg, L., Svensson, J.O. & Soñnerborg, A. 2004, "Efavirenz plasma concentrations in HIV-infected patients: Inter- and intraindividual variability and clinical effects", *Therapeutic Drug Monitoring*, Vol. 26, No. 3, pp. 267-270.
126. Tsuchiya, K., Gatanaga, H., Tachikawa, N., Teruya, K., et al 2004, "Homozygous CYP2B6*6*6 (Q172H and K262R) correlates with high plasma efavirenz concentrations in HIV-1 patients treated with standard efavirenz-containing regimens", *Biochemical and Biophysical Research Communications*, Vol. 319, No. 4, pp. 1322-1326.
127. Haas, D.W., Smeaton, L.M., Shafer, R.W., Robbins, G.K., et al 2005, "Pharmacogenetics of long-term responses to antiretroviral regimens containing efavirenz and/or nelfinavir: An adult AIDS clinical trials group study", *Journal of Infectious Diseases*, Vol. 192, No. 11, pp. 1931-1942.
128. Lopez-Cortes, L.F., Ruiz-Valderas, R., Pompyo, V., Aristides, A.G., et al 2002, "Pharmacokinetic interactions between efavirenz and rifampicin in HIV-infected patients with tuberculosis", *Clinical Pharmacokinetics*, Vol. 41, No. 9, pp. 681-690.
129. Ji, P., Damle, B., Xie, J., Unger, S.E., et al 2008, "Pharmacokinetic interaction between efavirenz and carbamazepine after multiple-dose administration in healthy subjects", *Journal of Clinical Pharmacology*, Vol. 48, No. 8, pp. 948-956.
130. Ping Liu, Foster, G., Labadie, R.R., Gutierrez, M.J., et al 2008, "Pharmacokinetic interaction between voriconazole and efavirenz at steady state in healthy male subjects", *Journal of Clinical Pharmacology*, Vol. 48, No. 1, pp. 73-84.
131. Veldkamp, A.I., Van Heeswijk, R.P.G., Meenhorst, P.L., Mulder, J.W., et al 1999, "Quantitative determination of efavirenz (DMP 266), a novel non-nucleoside reverse transcriptase inhibitor, in human plasma using isocratic reversed-phase high-performance

liquid chromatography with ultraviolet detection", *Journal of Chromatography B: Biomedical Sciences and Applications*, Vol. 734, No. 1, pp. 55-61.

132. "FDA notifications. Sustiva packaging instructions updated.", 2007, *AIDS alert*, Vol. 22, No. 4, pp. 45.

133. McCance-Katz, E.F., Moody, D.E., Morse, G.D., Friedland, G., et al 2006, "Interactions between buprenorphine and antiretrovirals. I. The nonnucleoside reverse-transcriptase inhibitors efavirenz and delavirdine", *Clinical Infectious Diseases*, Vol. 43, No. SUPPL. 4.

134. Boffito, M., Rossati, A., Reynolds, H.E., Hoggard, P.G., et al 2002, "Undefined duration of opiate withdrawal induced by efavirenz in drug users with HIV infection and undergoing chronic methadone treatment", *AIDS Research and Human Retroviruses*, Vol. 18, No. 5, pp. 341-342.

135. Weiner, M., Benator, D., Peloquin, C.A., Burman, W., et al 2005, "Evaluation of the drug interaction between rifabutin and efavirenz in patients with HIV infection and tuberculosis", *Clinical Infectious Diseases*, Vol. 41, No. 9, pp. 1343-1349.

136. Hesse, L.M., Von Moltke, L.L., Shader, R.I. & Greenblatt, D.J. 2001, "Ritonavir, efavirenz, and nelfinavir inhibit CYP2B6 activity in vitro: Potential drug interactions with bupropion", *Drug Metabolism and Disposition*, Vol. 29, No. 2, pp. 100-102.

137. Park-Wyllie, L.Y. & Antoniou, T. 2003, "Concurrent use of bupropion with CYP2B6 inhibitors, nelfinavir, ritonavir and efavirenz: A case series [2]", *AIDS*, Vol. 17, No. 4, pp. 638-640.

138. Sriwiriyan, S., Mahatthanatrakul, W., Ridditid, W. & Jaruratanasirikul, S. 2007, "Effect of efavirenz on the pharmacokinetics of ketoconazole in HIV-infected patients", *European Journal of Clinical Pharmacology*, Vol. 63, No. 5, pp. 479-483.

139. Damle, B., LaBadie, R., Crownover, P. & Glue, P. 2008, "Pharmacokinetic interactions of efavirenz and voriconazole in healthy volunteers", *British Journal of Clinical Pharmacology*, Vol. 65, No. 4, pp. 523-530.

140. Gerber, J.G., Rosenkranz, S.L., Fichtenbaum, C.J., Vega, J.M., et al 2005, "Effect of efavirenz on the pharmacokinetics of simvastatin, atorvastatin, and pravastatin: Results of AIDS Clinical Trials Group 5108 study", *Journal of Acquired Immune Deficiency Syndromes*, Vol. 39, No. 3, pp. 307-312.

141. Cassol, E., Page, T., Mosam, A., Friedland, G., et al 2005, "Therapeutic response of HIV-1 subtype C in African patients coinfecting with either *Mycobacterium tuberculosis* or human herpesvirus-8", *Journal of Infectious Diseases*, Vol. 191, No. 3, pp. 324-332.

142. Manfredi, R., Calza, L. & Chiodo, F. 2004, "Efavirenz Versus Nevirapine in Current Clinical Practice: A Prospective, Open-Label Observational Study", *Journal of Acquired Immune Deficiency Syndromes*, Vol. 35, No. 5, pp. 492-502.
143. Gulick, R.M., Ribaud, H.J., Shikuma, C.M., Lalama, C., et al 2006, "Three- vs four-drug antiretroviral regimens for the initial treatment of HIV-1 infection: A randomized controlled trial", *Journal of the American Medical Association*, Vol. 296, No. 7, pp. 769-781.
144. Pérez-Eliás, M.J., Moreno, A., Moreno, S., López, D., et al 2005, "Higher virological effectiveness of NNRTI-based antiretroviral regimens containing nevirapine or efavirenz compared to a triple NRTI regimen as initial therapy in HIV-1-infected adults", *HIV Clinical Trials*, Vol. 6, No. 6, pp. 312-319.
145. Akileswaran, C., Lurie, M.N., Flanigan, T.P. & Mayer, K.H. 2005, "Lessons learned from use of highly active antiretroviral therapy in Africa", *Clinical Infectious Diseases*, Vol. 41, No. 3, pp. 376-385.
146. Staszewski, S., Morales-Ramirez, J., Tashima, K.T., Rachlis, A., et al 1999, "Efavirenz plus zidovudine and lamivudine, efavirenz plus indinavir, and indinavir plus zidovudine and lamivudine in the treatment of HIV-1 infection in adults", *New England Journal of Medicine*, Vol. 341, No. 25, pp. 1865-1873.
147. Manfredi, R., Calza, L. & Chiodo, F. 2005, "Prospective, open-label comparative study of liver toxicity in an unselected population of HIV-infected patients treated for the first time with efavirenz or nevirapine", *HIV Clinical Trials*, Vol. 6, No. 6, pp. 302-311.
148. Lacy, C.F., Armstrong, L.L., Goldman, M.P. & Lance, M.A. (eds) 2005, *Drug Information Handbook*, Thirteenth edn, Lexi-Comp, Ohio.
149. Ward, D.J. & Curtin, J.M. 2006, "Switch from efavirenz to nevirapine associated with resolution of efavirenz-related neuropsychiatric adverse events and improvement in lipid profiles", *AIDS Patient Care and STDs*, Vol. 20, No. 8, pp. 542-548.
150. Lochet, P., Peyriere, H., Lothe, A., Mauboussin, J., et al 2003, "Long-term assessment of neuropsychiatric adverse reactions associated with efavirenz", *HIV Medicine*, Vol. 4, No. 1, pp. 62-66.
151. Blanch, J., Corbella, B., García, F., Parellada, E., et al 2001, "Manic syndrome associated with efavirenz overdose [5]", *Clinical Infectious Diseases*, Vol. 33, No. 2, pp. 270-271.
152. Takahashi, M., Ibe, S., Kudaka, Y., Okumura, N., et al 2007, "No observable correlation between central nervous system side effects and EFV plasma concentrations in Japanese HIV

- type 1-infected patients treated with EFV containing HAART", *AIDS Research and Human Retroviruses*, Vol. 23, No. 8, pp. 983-987.
153. Sundell, E., Thomas, D.R., Amason, C. & Doffitt, C. 2002, "Noteworthy vascular plants from Arkansas. II", *SIDA, Contributions to Botany*, Vol. 20, No. 1, pp. 409-418.
154. Herndon, A. 1988, "Ecology and systematics of *Hypoxis sessilis* and *H. wrightii* (Hypoxidaceae) in Southern Florida", *American Journal of Botany*, Vol. 75, No. 12, pp. 1803-1812.
155. Morice, I.M. 1970, "Seed fats of some new zealand and australian monocotyledons", *Phytochemistry*, Vol. 9, No. 8, pp. 1829-1833.
156. Singh, Y. 2007, "*Hypoxis* (Hypoxidaceae) in Southern Africa: Taxonomic notes", *South African Journal of Botany*, Vol. 73, No. 3, pp. 360-365.
157. Msonthi, J.D., Toyota, M., Marston, A. & Hostettmann, K. 1990, "A phenolic glycoside from *Hypoxis obtusa*", *Phytochemistry*, Vol. 29, No. 12, pp. 3977-3979.
158. Wiland-Szymańska, J. & Adamski, Z. 2002, "Taxonomic and morphological notes on *Hypoxis angustifolia* (Hypoxidaceae) from Africa, Madagascar, and Mauritius", *Novon*, Vol. 12, No. 1, pp. 142-151.
159. Marini-Bettolo, G.B., Patamia, M. & Nicoletti, M. 1982, "Research on African medicinal plants. II. Hypoxoside, a new glycoside of uncommon structure from *Hypoxis obtusa* Busch", *Tetrahedron*, Vol. 38, No. 11, pp. 1683-1687.
160. Wiland, J. 1997, "New species of the genus *Hypoxis* (Hypoxidaceae) in Central Africa (Zaire, Rwanda, Burundi)", *Fragmenta Floristica et Geobotanica*, Vol. 42, No. 2, pp. 411-422.
161. Nair, V.D.P. 2006, *Pharmaceutical analysis and drug interaction studies: African Potato (*Hypoxis hemerocallidea*)*, Rhodes University, Grahamstown, RSA.
162. Erasto, P., Adebola, P.O., Grierson, D.S. & Afolayan, A.J. 2005, "An ethnobotanical study of plants used for the treatment of diabetes in the Eastern Cape Province, South Africa", *African Journal of Biotechnology*, Vol. 4, No. 12, pp. 1458-1460.
163. Louw, C.A.M., Regnier, T.J.C. & Korsten, L. 2002, "Medicinal bulbous plants of South Africa and their traditional relevance in the control of infectious diseases", *Journal of Ethnopharmacology*, Vol. 82, No. 2-3, pp. 147-154.

164. Koduru, S., Grierson, D.S. & Afolayan, A.J. 2007, "Ethnobotanical information of medicinal plants used for treatment of cancer in the Eastern Cape Province, South Africa", *Current Science*, Vol. 92, No. 7, pp. 906-908.
165. Grierson, D.S. & Afolayan, A.J. 1999, "An ethnobotanical study of plants used for the treatment of wounds in the Eastern Cape, South Africa", *Journal of Ethnopharmacology*, Vol. 67, No. 3, pp. 327-332.
166. Suzuki, S. & Umezawa, T. 2007, "Biosynthesis of lignans and norlignans", *Journal of Wood Science*, Vol. 53, No. 4, pp. 273-284.
167. Chifundera, K., Palazzino, G., Messana, I., Ping, L., et al 1994, "Norlignan glucosides from *Curculigo recurvata*", *Phytochemistry*, Vol. 35, No. 5, pp. 1343-1348.
168. Drewes, S.E., Hall, A.J., Learmonth, R.A. & Upfold, U.J. 1984, "Isolation of hypoxoside from *Hypoxis rooperi* and synthesis of (E)-1,5-bis(3',4'-dimethoxyphenyl)pent-4-en-1-yne", *Phytochemistry*, Vol. 23, No. 6, pp. 1313-1316.
169. Bettolo, G.B.M., Patamia, M., Nicoletti, M., Galeffi, C., et al 1982, "Research on African medicinal plants—II : Hypoxoside, a new glycoside of uncommon structure from *hypoxis obtusa busch*", *Tetrahedron*, Vol. 38, No. 11, pp. 1683-1687.
170. Laporta, O., Pérez-Fons, L., Mallavia, R., Caturla, N., et al 2007, "Isolation, characterization and antioxidant capacity assessment of the bioactive compounds derived from *Hypoxis rooperi* corm extract (African potato)", *Food Chemistry*, Vol. 101, No. 4, pp. 1425-1437.
171. Marini-Bettolo, G.B., Nicoletti, M. & Messana, I. 1985, "Glucosides of *Hypoxis nyasica* bak. The structure of nyasoside, a new glucoside biologically related to hypoxoside", *Tetrahedron*, Vol. 41, No. 4, pp. 665-670.
172. Messana, I., Msonthi, J.D., De Vicente, Y., Multari, G., et al 1989, "Mononyasine A and mononyasine B: Two glucosides from *Hypoxis nyasica*", *Phytochemistry*, Vol. 28, No. 10, pp. 2807-2809.
173. Sibanda, S., Ntabeni, O., Nicoletti, M. & Galeffi, C. 1990, "Nyasol and 1,3(5)-diphenyl-1-pentene related glycosides from *Hypoxis angustifolia*", *Biochemical Systematics and Ecology*, Vol. 18, No. 7-8, pp. 481-483.
174. Liebenberg, R. W. Extraction of sterolins from plant material. *Patent No.* GB1417272 (A). 1975. Great Britain.

175. Pegel, K. H. Active plant extracts of hypoxidaceae and their use. *Patent No.* 393789. 1979. USA.
176. Nair, V.D.P. & Kanfer, I. 2008, "Sterols and sterolins in *Hypoxis hemerocallidea* (African potato)", *South African Journal of Science*, Vol. 104.
177. Bouic, P.J.D., Etsebeth, S., Liebenberg, R.W., Albrecht, C.F., et al 1996, "Beta-sitosterol and beta-sitosterol glucoside stimulate human peripheral blood lymphocyte proliferation: Implications for their use as an immunomodulatory vitamin combination", *International Journal of Immunopharmacology*, Vol. 18, No. 12, pp. 693-700.
178. Salen, G., Ahrens Jr., E.H. & Grundy, S.M. 1970, "Metabolism of beta-sitosterol in man.", *Journal of Clinical Investigation*, Vol. 49, No. 5, pp. 952-967.
179. Steenkamp, V., Gouws, M.C., Gulumian, M., Elgorashi, E.E., et al 2006, "Studies on antibacterial, anti-inflammatory and antioxidant activity of herbal remedies used in the treatment of benign prostatic hyperplasia and prostatitis", *Journal of Ethnopharmacology*, Vol. 103, No. 1, pp. 71-75.
180. Laporta, O., Funes, L., Garzón, M.T., Villalaín, J., et al 2007, "Role of membranes on the antibacterial and anti-inflammatory activities of the bioactive compounds from *Hypoxis rooperi* corm extract", *Archives of Biochemistry and Biophysics*, Vol. 467, No. 1, pp. 119-131.
181. Ojewole, J.A.O. 2006, "Antinociceptive, anti-inflammatory and antidiabetic properties of *Hypoxis hemerocallidea* Fisch. & C.A. Mey. (Hypoxidaceae) corm ['African Potato'] aqueous extract in mice and rats", *Journal of Ethnopharmacology*, Vol. 103, No. 1, pp. 126-134.
182. Mahomed, I.M. & Ojewole, J.A.O. 2003, "Hypoglycemic Effect of *Hypoxis hemerocallidea* Corm (African Potato) Aqueous Extract in Rats", *Methods and Findings in Experimental and Clinical Pharmacology*, Vol. 25, No. 8, pp. 617-623.
183. Risa, J., Risa, A., Adsersen, A., Gauguin, B., et al 2004, "Screening of plants used in southern Africa for epilepsy and convulsions in the GABAA-benzodiazepine receptor assay", *Journal of Ethnopharmacology*, Vol. 93, No. 2-3, pp. 177-182.
184. Katerere, D.R. & Eloff, J.N. 2008, "Anti-bacterial and anti-oxidant activity of *Hypoxis hemerocallidea* (Hypoxidaceae): Can leaves be substituted for corms as a conservation strategy?", *South African Journal of Botany*, Vol. 74, No. 4, pp. 613-616.

185. Gaidamashvili, M. & vanStaden, J. 2002, "Interaction of lectin-like proteins of South African medicinal plants with *Staphylococcus aureus* and *Bacillus subtilis*", *Journal of Ethnopharmacology*, Vol. 80, No. 2-3, pp. 131-135.
186. Kruger, P.B., de V. Albrecht, C.F., Liebenberg, R.W. & van Jaarsveld, P.P. 1994, "Studies on hypoxoside and rooperol analogues from *Hypoxis rooperi* and *Hypoxis latifolia* and their biotransformation in man by using high-performance liquid chromatography with in-line sorption enrichment and diode-array detection", *Journal of Chromatography B: Biomedical Sciences and Applications*, Vol. 662, No. 1, pp. 71-78.
187. Coetzee, J.F., Kruger, P.B., Albrecht, C.F., Jahed, N., et al 1996, "Pharmacokinetic behaviour and cardiovascular effects of intravenously administered hypoxoside and rooperol", *Arzneimittel-Forschung/Drug Research*, Vol. 46, No. 10, pp. 997-1000.
188. Albrecht, C.F., Kruger, P.B., Smit, B.J., Freestone, M., et al 1995, "The pharmacokinetic behaviour of hypoxoside taken orally by patients with lung cancer in a phase I trial", *South African Medical Journal*, Vol. 85, No. 9, pp. 861-865.
189. Berges, R.R., Windeler, J., Trampisch, H.J., Senge, T., et al 1995, "Randomised, placebo-controlled, double-blind clinical trial of β -sitosterol in patients with benign prostatic hyperplasia", *The Lancet*, Vol. 345, No. 8964, pp. 1529-1532.
190. Breytenbach, U., Clark, A., Lamprecht, J. & Bouic, P. 2001, "Flow cytometric analysis of the Th1-Th2 balance in healthy individuals and patients infected with the human immunodeficiency virus (HIV) receiving a plant sterol/sterolin mixture", *Cell Biology International*, Vol. 25, No. 1, pp. 43-49.
191. Bouic, P.J.D., Clark, A., Brittle, W., Lamprecht, J.H., et al 2001, "Plant sterol/sterolin supplement use in a cohort of South African HIV-infected patients - Effects on immunological and virological surrogate markers", *South African Medical Journal*, Vol. 91, No. 10 I, pp. 848-850.
192. Erlwanger, K.H. & Cooper, R.G. 2008, "The effects of orally administered crude alcohol and aqueous extracts of African potato (*Hypoxis hemerocallidea*) corm on the morphometry of viscera of suckling rats", *Food and Chemical Toxicology*, Vol. 46, No. 1, pp. 136-139.
193. Smit, B.J., Albrecht, C.F., Liebenberg, R.W., Kruger, P.B., et al 1995, "A phase I trial of hypoxoside as an oral prodrug for cancer therapy - Absence of toxicity", *South African Medical Journal*, Vol. 85, No. 9, pp. 865-870.
194. Mills, E., Cooper, C., Seely, D. & Kanfer, I. 2005, "African herbal medicines in the treatment of HIV: *Hypoxis* and *Sutherlandia*. An overview of evidence and pharmacology", *Nutrition Journal*, Vol. 4, No. 19.

195. Drewes, S. and Liebenberg, R. W. Pentene-diphenyl-diglucoside containing compound. *Patent No.* EP0092226(A2). 1987. Europe.
196. Drewes, S. and Liebenberg, R. W. Rooperol and its derivatives. *Patent No.* EP0130829(A2). 1985. Europe.
197. Wenteler, G. L., Pegel, K. H. and Drewes, S. Process for preparation of rooperol, hypoxoside and derivatives thereof. *Patent No.* EP0206765(A2). 1986. Europe.
198. Liebenberg, R. W., Kruger, P., Bouic, P. J. D. and De Vos Albrecht, C. F. Method of treating viral infections. *Patent No.* 5609874. 1997. USA.
199. "An introduction to chromatographic methods" in *Fundamentals of analytical chemistry*, eds. D.A. Skoog, D.M. West & J.F. Holler, Seventh edn, Saunders College Publishing, Florida, USA 1996, , pp. 660-685.
200. Dong, M., Paul, R. & Gearshanov, L. 2001, "Getting the peaks perfect: System suitability for HPLC", *Today's Chemist*, Vol. 10, No. 9, pp. 38-40.
201. Snyder, L.R., Kirkland, J.J. & Glajch, J.L. (eds) 1997, *Practical HPLC Method Development*, Second edn, John Wiley & Sons Inc, Canada.
202. *U.S. Pharmacopeia 29*, 2006, United States Pharmacopeia, Maryland, USA.
203. Liang, Y.Z., Xie, P. & Chan, K. 2004, "Quality control of herbal medicines", *Journal of Chromatography B: Analytical Technologies in the Biomedical and Life Sciences*, Vol. 812, No. 1-2 SPEC. ISS., pp. 53-70.
204. Xie, P., Chen, S., Liang, Y.Z., Wang, X., et al 2006, "Chromatographic fingerprint analysis-a rational approach for quality assessment of traditional Chinese herbal medicine", *Journal of Chromatography A*, Vol. 1112, No. 1-2, pp. 171-180.
205. Gong, F., Liang, Y.Z., Xie, P.-. & Chau, F.-. 2003, "Information theory applied to chromatographic fingerprint of herbal medicine for quality control", *Journal of Chromatography A*, Vol. 1002, No. 1-2, pp. 25-40.
206. Yan, S.K., Xin, W.F., Luo, G.A., Wang, Y.M., et al 2005, "Simultaneous determination of major bioactive components in Qingkailing injection by high-performance liquid chromatography with evaporative light scattering detection", *Chemical and Pharmaceutical Bulletin*, Vol. 53, No. 11, pp. 1392-1395.

207. Tsao, R. & Deng, Z. 2004, "Separation procedures for naturally occurring antioxidant phytochemicals", *Journal of Chromatography B: Analytical Technologies in the Biomedical and Life Sciences*, Vol. 812, No. 1-2 SPEC. ISS., pp. 85-99.
208. Vinesi, P., Serafini, M., Nicoletti, M., Spano, L., et al 1990, "Plant regeneration and hypoxoside content in *Hypoxis obtusa*", *Journal of Natural Products (Lloydia)*, Vol. 53, No. 1, pp. 196-199.
209. Betto, P., Gabrielle, R. & Galeffi, C. 1992, "Determination of the norlignan glucosides of Hypoxidaceae by high-performance liquid chromatography", *Journal of Chromatography*, Vol. 594, No. 1-2, pp. 131-135.
210. Rouzes, A., Berthoin, K., Xuereb, F., Djabarouti, S., et al 2004, "Simultaneous determination of the antiretroviral agents: amprenavir, lopinavir, ritonavir, saquinavir and efavirenz in human peripheral blood mononuclear cells by high-performance liquid chromatography–mass spectrometry", *Journal of Chromatography B*, Vol. 813, No. 1-2, pp. 209-216.
211. Matthews, C.Z., Woolf, E.J., Mazenko, R.S., Haddix-Wiener, H., et al 2002, "Determination of efavirenz, a selective non-nucleoside reverse transcriptase inhibitor, in human plasma using HPLC with post-column photochemical derivatization and fluorescence detection", *Journal of Pharmaceutical and Biomedical Analysis*, Vol. 28, No. 5, pp. 925-934.
212. Pereira, E.A., Micke, G.A. & Tavares, M.F.M. 2005, "Determination of antiretroviral agents in human serum by capillary electrophoresis", *Journal of Chromatography A*, Vol. 1091, No. 1-2, pp. 169-176.
213. Kappelhoff, B.S., Rosing, H., Huitema, A.D.R. & Beijnen, J.H. 2003, "Simple and rapid method for the simultaneous determination of the non-nucleoside reverse transcriptase inhibitors efavirenz and nevirapine in human plasma using liquid chromatography", *Journal of Chromatography B*, Vol. 792, No. 2, pp. 353-362.
214. Notari, S., Bocedi, A., Ippolito, G., Narciso, P., et al 2006, "Simultaneous determination of 16 anti-HIV drugs in human plasma by high-performance liquid chromatography", *Journal of Chromatography B*, Vol. 831, No. 1-2, pp. 258-266.
215. Keil, K., Frerichs, V.A., DiFrancesco, R. & Morse, G.D. 2003, "Reverse phase high-performance liquid chromatography method for the analysis of amprenavir, efavirenz, indinavir, lopinavir, nelfinavir and its active metabolite (M8), ritonavir, and saquinavir in heparinized human plasma", *Therapeutic Drug Monitoring*, Vol. 25, No. 3, pp. 340-346.

216. Usami, Y., Oki, T., Nakai, M., Sagisaka, M., et al 2003, "A simple HPLC method for simultaneous determination of lopinavir, Ritonavir and Efavirenz", *Chemical and Pharmaceutical Bulletin*, Vol. 51, No. 6, pp. 715-718.
217. Ramachandran, G., Kumar, A.K.H., Swaminathan, S., Venkatesan, P., et al 2006, "Simple and rapid liquid chromatography method for determination of efavirenz in plasma", *Journal of Chromatography B: Analytical Technologies in the Biomedical and Life Sciences*, Vol. 835, No. 1-2, pp. 131-135.
218. Boffito, M., Tija, J., Reynolds, H.E., Hoggard, P.G., et al 2002, "Simultaneous determination of rifampicin and efavirenz in plasma", *Therapeutic Drug Monitoring*, Vol. 24, No. 5, pp. 670-674.
219. Lakshmi, S.A., Kishore, K.K., Ravi, K.D.V.R., Mohan, K.C., et al 2007, "Development and validation of a liquid chromatographic method for determination of efavirenz in human plasma", *Chromatographia*, Vol. 65, No. 5-6, pp. 359-361.
220. Sarasa-Nacenta, M., López-Púa, Y., López-Cortés, L.F., Mallolas, J., et al 2001, "Determination of efavirenz in human plasma by high-performance liquid chromatography with ultraviolet detection", *Journal of Chromatography B: Biomedical Sciences and Applications*, Vol. 763, No. 1-2, pp. 53-59.
221. Langmann, P., Schirmer, D., Vañth, T., Zilly, M., et al 2001, "High-performance liquid chromatographic method for the determination of HIV-1 non-nucleoside reverse transcriptase inhibitor efavirenz in plasma of patients during highly active antiretroviral therapy", *Journal of Chromatography B: Biomedical Sciences and Applications*, Vol. 755, No. 1-2, pp. 151-156.
222. Rezk, N.L., Tidwell, R.R. & Kashuba, A.D.M. 2004, "High-performance liquid chromatography assay for the quantification of HIV protease inhibitors and non-nucleoside reverse transcriptase inhibitors in human plasma", *Journal of Chromatography B*, Vol. 805, No. 2, pp. 241-247.
223. Dailly, E., Raffi, F. & Jolliet, P. 2004, "Determination of atazanavir and other antiretroviral drugs (indinavir, amprenavir, nelfinavir and its active metabolite M8, saquinavir, ritonavir, lopinavir, nevirapine and efavirenz) plasma levels by high performance liquid chromatography with UV detection", *Journal of Chromatography B: Analytical Technologies in the Biomedical and Life Sciences*, Vol. 813, No. 1-2, pp. 353-358.
224. Turner, M.L., Reed-Walker, K., King, J.R. & Acosta, E.P. 2003, "Simultaneous determination of nine antiretroviral compounds in human plasma using liquid chromatography", *Journal of Chromatography B*, Vol. 784, No. 2, pp. 331-341.

225. U.S. Department of Health and Human Services. Food and Drug Administration, *Guidance for Industry Bioanalytical Method Validation*: 2001. Maryland, USA.
226. Trudnowski, R.J. & Rico, C.R. 1974, "Specific Gravity of Blood and Plasma at 4 and 37°C", *Clinical Chemistry*, Vol. 20, No. 5, pp. 615-616.
227. Bansal, S. & DeStefano, A. 2007, "Key elements of bioanalytical method validation for small molecules.", *The AAPS Journal*, Vol. 9, No. 1, pp. E109-114.
228. Nowatzke, W. & Woolf, E. 2007, "Best practices during bioanalytical method validation for the characterization of assay reagents and the evaluation of analyte stability in assay standards, quality controls, and study samples", *AAPS Journal*, Vol. 9, No. 2, pp. E117-E122.
229. The European Agency for the Evaluation of Medicinal Products, *Note for Guidance on Investigation of Drug Interactions*: 1997. London.
230. Davit, B., Reynolds, K., Yuan, R., Ajayi, F., et al 1999, "FDA evaluations using in vitro metabolism to predict and interpret in vivo metabolic drug-drug interactions: Impact on labeling", *Journal of Clinical Pharmacology*, Vol. 39, No. 9, pp. 899-910.
231. Hewitt, N.J., de Kanter, R. & LeCluyse, E. 2007, "Induction of drug metabolizing enzymes: A survey of in vitro methodologies and interpretations used in the pharmaceutical industry-Do they comply with FDA recommendations?", *Chemico-Biological Interactions*, Vol. 168, No. 1, pp. 51-65.
232. Huang, S.M., Strong, J.M., Zhang, L., Reynolds, K.S., et al 2008, "Drug interactions/review: New era in drug interaction evaluation: US Food and Drug Administration update on CYP enzymes, transporters, and the guidance process", *Journal of Clinical Pharmacology*, Vol. 48, No. 6, pp. 662-670.
233. Wooding, W. 1994, *Planning pharmaceutical clinical trials Basic statistical principles*, John Wiley and Sons, Inc, New York, USA.
234. Bjornsson, T.D., Callaghan, J.T., Einolf, H.J., Fischer, V., et al 2003, "The conduct of in vitro and in vivo drug-drug interaction studies: A Pharmaceutical Research and Manufacturers of America (PhRMA) perspective", *Drug Metabolism and Disposition*, Vol. 31, No. 7, pp. 815-832.
235. U.S. Department of Health and Human Services. Food and Drug Administration, *In vivo drug metabolism/drug interaction studies- study design, data analysis and recommendations for dosing and labelling*: 1999. Maryland, USA.

236. U.S. Department of Health and Human Services. Food and Drug Administration, *Bioavailability and bioequivalence studies for orally administered drug products - General considerations*: 2003. Maryland, USA.
237. Bois, F.Y., Tozer, T.N., Hauck, W.W., Chen, M.L., et al 1994, "Bioequivalence: Performance of several measures of extent of absorption", *Pharmaceutical Research*, Vol. 11, No. 5, pp. 715-722.
238. Gaudreault, J., Potvin, D., Lavigne, J. & Lalonde, R.L. 1998, "Truncated area under the curve as a measure of relative extent of bioavailability: Evaluation using experimental data and Monte Carlo simulations", *Pharmaceutical Research*, Vol. 15, No. 10, pp. 1621-1629.
239. Macheras, P., Symillides, M. & Reppas, C. 1994, "The cutoff time point of the partial area method for assessment of rate of absorption in bioequivalence studies", *Pharmaceutical Research*, Vol. 11, No. 6, pp. 831-834.
240. Sathe, P., Venitz, J. & Lesko, L. 1999, "Evaluation of truncated areas in the assessment of bioequivalence of immediate release formulations of drugs with long half-lives and of C_{max} with different dissolution rates", *Pharmaceutical Research*, Vol. 16, No. 6, pp. 939-943.
241. Marzo, A., Ceppi Monti, N. & Vuksic, D. 1999, "Experimental, extrapolated and truncated areas under the concentration- time curve in bioequivalence trials", *European Journal of Clinical Pharmacology*, Vol. 55, No. 9, pp. 627-631.
242. The European Agency for the Evaluation of Medicinal Products, *Note for guidance on investigation of bioavailability and bioequivalence*: 2001. London.
243. Bolton, S. (ed) 1997, *Pharmaceutical Statistics: Practical and Clinical Applications*, Third edn, Marcel Dekker, Inc, New York.
244. Mitchell, C.L. 1976, "The design and analysis of experiments for the assessment of drug interactions", *Annals of the New York Academy of Sciences*, Vol. Vol.281, pp. 118-135.
245. Hauck, W.W., Hauschke, D., Diletti, E., Bois, F.Y., et al 1997, "Choice of student's t- or Wilcoxon-based confidence intervals for assessment of average bioequivalence", *Journal of Biopharmaceutical Statistics*, Vol. 7, No. 1, pp. 179-189.
246. Steinijs, V.W., Hartmann, M., Huber, R. & Radtke, H.W. 1991, "Lack of pharmacokinetic interaction as an equivalence problem", *International Journal of Clinical Pharmacology Therapy and Toxicology*, Vol. 29, No. 8, pp. 323-328.

247. Fuhr, U. 2007, "What is the true risk of a pharmacokinetic drug-drug interaction?", *European Journal of Clinical Pharmacology*, Vol. 63, No. 10, pp. 897-899.
248. Huang, S.M., Lesko, L.J. & Williams, R.L. 1999, "Assessment of the quality and quantity of drug-drug interaction studies in recent NDA submissions: Study design and data analysis issues", *Journal of Clinical Pharmacology*, Vol. 39, No. 10, pp. 1006-1014.
249. Rhodes University, *Ethical Standards: Relative to Research on Human and Animal subjects*: 2005. Grahamstown, South Africa.
250. The World Medical Association, *Ethical Principles for Medical Research Involving Human Subjects*: 2004. France.
251. International Conference on Harmonisation, *Guideline for Good Clinical Practice*: 1996. Geneva, Switzerland.
252. Gibaldi, M. & Perrier, D. (eds) 1982, *Pharmacokinetics*, Second edn, Marcel Dekker, Inc., New York, USA.
253. Schuirmann, D.J. 1987, "A comparison of the Two One-Sided Tests Procedure and the Power Approach for assessing the equivalence of average bioavailability", *Journal of Pharmacokinetics and Biopharmaceutics*, Vol. 15, No. 6, pp. 657-680.
254. Marzolini, C., Telenti, A., Decosterd, L.A., Greub, G., et al 2001, "Efavirenz plasma levels can predict treatment failure and central nervous system side effects in HIV-1-infected patients", *AIDS*, Vol. 15, No. 1, pp. 71-75.
255. Kappelhoff, B.S., Van Leth, F., Robinson, P.A., MacGregor, T.R., et al 2005, "Are adverse events of nevirapine and efavirenz related to plasma concentrations?", *Antiviral Therapy*, Vol. 10, No. 4, pp. 489-498.
256. Langmann, P., Weissbrich, B., Desch, S., Vañth, T., et al 2002, "Efavirenz plasma levels for the prediction of treatment failure in heavily pretreated HIV-1 infected patients.", *European journal of medical research*, Vol. 7, No. 7, pp. 309-314.