

PLASTIC CHANGES IN SPINAL FUNCTION OF PRE-PUBESCENT SCOLIOTIC  
CHILDREN ENGAGED IN AN EXERCISE THERAPY PROGRAMME.

BY

GILL SOLBERG

THESIS

Submitted in fulfilment of the requirements for the degree

Master of Arts

Department of Human Movement Studies

Rhodes University, 1993

Grahamstown, South Africa

## ABSTRACT

Previous studies of the effect of exercise therapy on scoliosis have demonstrated progression of spinal curves despite vigorous exercise regimens. This study presents evidence to the contrary.

Ten children with functional scoliosis and attendant upper thoracic asymmetries were analyzed both before and after a specific exercise therapy programme, in order to determine the effect of the therapy on spinal functionality and the scoliotic curve. The effect of this intensive treatment, in which the subjects underwent a five-month exercise training programme with a total of 60 one-hour sessions, was investigated in a controlled clinical trial.

A subjective and objective appraisal of posterior trunk asymmetry in schoolchildren aged 7-18 is reported. Selected functional and anthropometric measurements were made before and after the treatment, and antero-posterior x-rays were used to indicate changes in the scoliotic curve. New methods are described for quantifying the scoliotic curves in each child.

Post-treatment tests showed a significant ( $p < 0.05$ ) decrease in Cobb's angles as well as a significant reduction in all the spinal and thoracic functional asymmetries observed in the study.

The findings suggest that selective exercise programmes can contribute to improvement in cases of functional scoliosis. The study sheds new light on problems related to scoliosis and the benefits of exercise rehabilitation.

Data on the incidence of scoliosis amongst 1052 black children are also presented and discussed.

## ACKNOWLEDGEMENTS

The author wishes to express his sincere thanks and appreciation to the following, for their assistance in this study:

Professor J Charteris, who supervised this thesis, putting in a great deal of time and effort. His support, guidance and advice has been greatly appreciated.

Professor PA Scott who assisted me on numerous occasions in contacting the schools from which the subjects were selected.

My appreciation is also extended to Ros Parker for the friendship which has grown over the two years of our stay in South Africa and to my wife Orly and our daughter Rony for being so tolerant and supportive.

TABLE OF CONTENTS

	PAGE
CHAPTER 1 - INTRODUCTION . . . . .	1
Statement of the problem . . . . .	3
Research hypothesis . . . . .	5
Delimitations . . . . .	6
Limitations . . . . .	7
CHAPTER 2 - REVIEW OF LITERATURE	
Introduction . . . . .	8
The incidence of scoliosis . . . . .	12
The etiology of scoliosis . . . . .	18
The importance of early detection and preventive treatment of scoliosis . . . . .	37
The evaluation of scoliosis . . . . .	52
The role of exercise in the treatment of scoliosis . .	66
CHAPTER 3 - EXPERIMENTAL METHODS AND PROCEDURES	
Introduction . . . . .	70
Pilot study . . . . .	70
Screening programme . . . . .	71
Subject selection . . . . .	72
Clinical examination . . . . .	73
Equipment for anthropometric measurements . . . . .	75
Functional measurements . . . . .	75
Equipment for functional measurements . . . . .	77

	PAGE
Measurements on Radiographs . . . . .	81
Exercise procedures and programme . . . . .	86
Assistants . . . . .	87

CHAPTER 4 - RESULTS AND DISCUSSION

Pilot study results . . . . .	89
Analysis of clinical data in the pilot study . . . . .	91
Experimental Results . . . . .	95

CHAPTER 5 - SUMMARY, CONCLUSIONS AND RECOMMENDATION

Aims of study . . . . .	118
Method . . . . .	119
Results . . . . .	121
Conclusions . . . . .	123
Recommendations . . . . .	124

REFERENCES . . . . .	125
----------------------	-----

APPENDICES

A. Statement of the American Academy of Orthopaedic Surgeons - 1974 . . . . .	135
B. Letter to parents . . . . .	136
C. Screening tests form . . . . .	137
D. Clinical Measurements form . . . . .	138
E. CV of area under the curve measurement . . . . .	139
F. CV of anthropometric measurements . . . . .	140
G. CV of functional measurements . . . . .	141

H.	Informed consent (exercise therapy programme) . . . . .	142
I.	Subject's treatment card . . . . .	143
J.	List of therapeutic exercises . . . . .	144

## LIST OF TABLES

TABLE	PAGE
I. Physical characteristics of subjects . . . . .	72
II. Screening Programme Results . . . . .	90
III. Clinical examination results . . . . .	91
IV. Asymmetry ratios from the clinical measurements (H/L-1) . . . . .	93
V. Angle of Asymmetry Resulting from Differences in Acromial Heights . . . . .	94
VI. Distribution of Pre-Treatment Roentgenographic Signs . . . . .	95
VII. Distribution of Pre-Treatment Roentgenographic Signs among subjects with scoliosis of 5° or more	96
VIII. Programme-Effects on Selected Asymmetry Measures (H/L)-1 . . . . .	97
IX. Programme-Effects on Acromial Angle Asymmetry . .	98
X. Programme-Effects on Functional Measurements . . .	100
XI. Roentgenographic Results of Pre-Post Treatment Curves (Cobb angles) . . . . .	104
XII. The area under the curve (SRD=C/A) . . . . .	106

LIST OF FIGURES

FIGURE	PAGE
1. "C" curve scoliosis . . . . .	15
2. "S" curve scoliosis . . . . .	16
3. Cobb method of measurement (Cassella and Hall, 1991) . . . . .	17
4. ROM of the spine (White and Panjabi, 1978) . . . . .	23
5. Ventral ray of the Triradiate System (Nudelman and Reis, 1990) . . . . .	34
6. Upper and lower dorsal rays of the Triradiate System (Nudelman and Reis, 1990) . . . . .	34
7. Formation of the thoracic scoliosis (Nudelman and Reis, 1990) . . . . .	35
8. Formation of the lumbar scoliosis (Nudelman and Reis, 1990) . . . . .	35
9. Forces deforming the chest wall (Nudelman and Reis, 1990) . . . . .	36
10. Muscle balance (Alter, 1988) . . . . .	41
11. The pattern of growth of a scoliotic vertebra (Smith <i>et al.</i> , 1991) . . . . .	46
12. AUSCAN System (Assente <i>et al.</i> , 1987) . . . . .	55
13. Moir'e topography (Cassella and Hall, 1991) . . . . .	56
14. Integrated Shape Investigation System (ISIS) (Cassella and Hall, 1991) . . . . .	57
15. Measurements of bony landmark positions with a sliding pointer (Smith <i>et al.</i> , 1988) . . . . .	60
16. Forward bending test (Salter, 1984) . . . . .	62
17. Frontal plane behind the Scoliosometer (Occhipinti <i>et al.</i> , 1989) . . . . .	63
18. Measurement of distance between C <sub>7</sub> and seating plane with patient upright seated position (Occhipinti <i>et al.</i> , 1989) . . . . .	64
19. Measurement of distance between C <sub>7</sub> and seating surface with patient bending sideways (Occhipinti <i>et al.</i> , 1991) . . . . .	65

FIGURE	PAGE
20. Examination of the spine from behind . . . . .	72
21. Scapula-to-Spine distance . . . . .	75
22. Trunk flexion measurement (C <sub>7</sub> -S <sub>1</sub> ) (Hay and Reid, 1978) . . . . .	77
23. Shoulder flexibility measurement (Hay and Reid, 1978) . . . . .	77
24. Angular asymmetry of scapulae . . . . .	78
25. Asymmetry of acromial height . . . . .	79
26. Angle of asymmetry . . . . .	80
27. Measurements of the width and height of each vertebral body, to find its centre . . . . .	82
28. Measurement of spinal deviation on radiographs . .	83
29. Measurement of the area under the curve . . . . .	84
30. A compensating polar planimeter . . . . .	85
31. Direction of asymmetry in acromial height (R-L) .	90
32. Incidence of Lateral Asymmetries (N=1052) . . . . .	91
33. Roentgenographic Results of Pre- versus post-treatment curves (Cobb Angles) . . . . .	103
34. Pre-Post Treatment Results of the Area Under the Curve (SRD=C/A) . . . . .	105
35. Percentage Reduction in scoliotic Curves After Treatment . . . . .	105
36. Spinal deviation scores ( $\Sigma=d/h$ ) . . . . .	107
37. Graphic presentation of scoliotic curves . . . . .	108
38. X-ray films of scoliotic spines before and after treatment . . . . .	109

## CHAPTER 1

### INTRODUCTION

Phylogenetically back problems probably coincided with orthograde posture. Many authors have maintained that man's orthograde posture is the main contributing factor to the high incidence of spinal deformities (Gustavsen, 1985) and in their search for a single causative mechanism, opinions have differed as to the effect of upright posture on the spine. Doctors and therapists have been attempting to alleviate back strain since the beginning of the practice of medicine and a number of opposing approaches to management have been proposed (Cyriax, 1979). Theories and methods have developed over the centuries to relieve this malady, but to date no panacea has been found.

Normal function and alignment of the body provides the basis for efficient movement and endurance and depends on the inter-relationship of all structures involved, considering both the anatomical and physiological aspects (Kendall, 1983). Clearly bones and joints must be in appropriate mechanical alignment in order to endure the stress of movement and body weight. Such alignment facilitates optimal ranges of motion in and through all planes (frontal, sagittal and transverse). The mobile segment of the spine consists of the three-joint complex (anterior intervertebral disc and the posterior facet joints) and associated ligaments and fascia. Altered mechanics of any one of these structures might affect the others to a greater or lesser extent.

Balanced alignment is of considerable importance in numerous daily activities and clinicians and investigators have used various methods to develop it. The development of balanced strength in opposing groups of muscles is important for achieving symmetrical posture. The results of failure of this development typically include distortion of normal skeletal alignment (Nudelman and Reis, 1990).

In the continued search for the etiology of spinal deformities, authors began to recognize the multifactorial nature of the problem and the difficulty in establishing an accurate diagnosis. To a very large extent, measures or value judgments of "poor" posture suggest the cause to be an interaction of unbalanced pull of muscles, inadequate muscle tone, and deficient neural control (Kendall, 1983) and foreshortening of muscles can be a cause of body malalignment or an adaptive response to habitual position (Nudelman and Reis, 1990).

Dynamic bodily alignment is a constantly changing phenomenon commensurate with the level of growth and development. Posture is adjusted not only when objects are lifted and carried, but even when standing or sitting unconstrained by environmental loads. This can be observed in foot movements of individuals who are in a standing posture and is accentuated when visual cues are removed and dynamic postural adjustments are made using only kinaesthetic feedback (Zernicke et al., 1982).

This study proposed to investigate one method of therapeutic intervention in cases of postural malalignment.

#### STATEMENT OF THE PROBLEM

Postural malalignment seems to be enough of a problem for society that a viable solution to alleviate it is necessary. There are as many procedures for correcting abnormal postures as there are forms of postural malalignment. Among these malalignments is scoliosis, which constitutes a complex problem and defies simplistic treatment.

Scoliosis is a general term used to describe any lateral curvature of the spine. It is a physical condition that is defined in mechanical terms (Schultz, 1984). Scoliosis exist if vertebrae are laterally offset from the mid-line of the body when the trunk is upright. The curvature may occur in the cervical, thoracic or lumbar regions of the spine and if untreated during the growth years, scoliosis can lead to severe deformities which have a negative impact on various systems of the body. This deformity, which most often develops in childhood, can lead ontogenetically to structural abnormalities of the pelvis, vertebrae and thoracic cage (Cassella and Hall, 1991). These adaptations can occur as morphological changes in bone as well as alterations in the control mechanism for locomotion. In many cases the cause of the adaptation is mechanical in nature. One type of adaptation is structural in nature and can be seen in bone

when it changes its density and architecture in response to alterations in mechanical stress, as frequently happen in cases of lateral deviations of the spine (Martin *et al.*, 1986).

The key to the prevention of spinal deviations is early identification and early treatment. It is important to examine the child periodically for the suspected presence of scoliosis, particularly during growth spurts (Loncar *et al.*, 1991).

The most common form of the disorder is adolescent idiopathic scoliosis, which involves a lateral curvature of the spine of unknown cause, and can either be functional or structural (Steindler, 1964). Most methods of treatment of scoliosis are mechanical methods. Bracing, electrical stimulation of muscle, or surgical instrumentation of the spine all attempt to correct scoliosis by application of forces to the trunk (WYnarsky and Schultz, 1991). Although it is true that certain defects in posture can be corrected only by bracing or surgery, many postural problems seen in adults could have been prevented by education to counter the ill-effects of inefficient movement habits during childhood. There are many which can also be corrected or lessened by exercise. These are the faults which can be related to weakened muscles or tightened ligaments. However, no sufficient attempt has been made in previous studies to determine whether therapeutic exercises are effective in

these cases. A great deal has yet to be learned regarding the relationship between physical activity and lateral deviations of the spine.

There is substantial clinical controversy regarding the use of therapeutic exercises in the treatment of scoliosis and there is little work to be found in the literature dealing with this question. Most doctors and health care practitioners believe that physical exercises have no effect on either reducing the curve or preventing its progression. The primary benefit of exercises according to this opinion is therefore only to help the medical bracing programme in reducing back pain and to maintain or improve range of motion. This attitude does not attach much importance to physical exercises as a significant factor in the treatment. One goal of the present project was to examine the possibility of obtaining postural improvement in cases of scoliosis and to examine the extent to which spinal function can be improved. If indeed such exercise is deemed to have been effective in improving the malalignment, perhaps the need to reconsider prevailing orthopaedic concepts might be suggested.

#### **RESEARCH HYPOTHESIS**

This study was designed to determine whether it is possible to show reduction of the lateral deviation in a group of functional scoliotic children following a 20-week

period of therapeutic exercises, and to examine the extent to which spinal function can be improved.

The following research hypothesis was developed for investigation (0.05 level of significance):

There is no change in the scoliotic curve and functionality due to an exercise therapy programme.

Stated statistically, the nul-hypothesis was:

$$H_0: \mu SC_{be} = \mu SC_{ae}$$

Where SC is the mean spinal curve either before exercise programme (be), or after exercise programme (ae).

The alternative hypothesis was:

$$H_a: \mu SC_{be} \neq \mu SC_{ae}$$

#### DELIMITATIONS

1052 children were screened for scoliosis, from which group 10 with lateral deviations of 5° or more volunteered to participate in this study. The study was delimited to provision of exercise therapy only to children showing greater than 5° lateral curvatures (as measured by Cobb's angle). It was delimited also to Township children aged 7-18, these representing the population deemed to be both most vulnerable and least well catered-for in the health care system.

## LIMITATIONS

1. One of the most commonly encountered problems in the field of spinal deformities is the lack of clarity attending definitions of what is "normal" (Koeslag, 1993). It has taken researchers many years to describe what is normal, trying to define an optimal posture, and several attempts have been made in spinal research to develop optimal criteria. However, the results of those studies have been quite unsuccessful. Thus it is unlikely that we are now in a position to define universal normal posture patterns for a wide variety of children.

2. Biomechanical evaluations of the spine are often done in a nonstandardized manner which makes it difficult to compare the results of one study with those of another. Thus, generalizability may be limited in the case of this study.

3. The study had to be delimited to a certain number of subjects from Grahamstown, South Africa, Consequently a limitation was that the children were from only one geographical location.

4. The number of subjects (10) constitutes a limitation in that the data are insufficient to generate conclusive results.

## CHAPTER 2

### REVIEW OF LITERATURE

#### INTRODUCTION

In the last Victorian half century it was common for physical and health educators to be preoccupied with "posture". Since the time of the early Greeks, emphasis has been laid on the desirability of "good posture". Many tests and measures of posture have been devised and widely used. Published "postural standards" were widespread and much time has been spent in attempting to bring the youth up to these standards (Kisner and Colby, 1985).

Much of this has been done with almost no research evidence of the physiological or functional advantages of what has been glibly called "good posture". Most physiology and medical textbooks provide lists of "normal values" without, however, stating the criteria by which they are judged to be normal (Koeslag, 1993). This convention has not been subjected to testing in clinical trials or laboratory experiments, and has thus become a matter of belief rather than a scientific verity.

Part of the difficulty encountered in identifying postural principles lies in the fact that no individual's posture can be adequately described. Posture means that the body as a whole or in part is held in some or other position.

The Latin word, "postura", implies the same idea. It denotes a state of having been "placed" or "arranged". But a multi-segmented organism such as the human body cannot be said to "have" a single posture. It assumes many positions and rarely holds any of them for an appreciable time.

Most authors consider postural muscles as being those which maintain erect standing in man. It is often forgotten however, that under ideal physiological situations, the erect standing position is so well balanced that little or no activity is necessary to maintain it. When activity does occur to a small degree, it does so irregularly (Janda, 1983). Thus there is a dilemma: we consider as postural muscles those which maintain erect standing, but for maintaining erect standing no muscle activity is needed. Basmajian (1967) noted this paradox and tried to solve it. According to him, in the narrowest and most limited sense, posture may be considered to be the upright, well-balanced stance of the human subject in a "normal position". In this sense, the subject of posture would deal only with the maintenance of the erect person's position against the force of gravity. But a broader, more generous and more palatable definition would not exclude the sitting and reclining positions which human beings assume in their activities of daily living.

Roaf (1977) preferred to define posture as "the position the body assumes in preparation for the next movement". Mere

uprightness which is static is, according to Roaf, not "true posture". This citation of some opinions shows just how vague the concept of posture is, and how entrenched the position that in principle, "posture" is understood as something which is more or less apart from the general function of the motor system. Posture is considered mainly as a static function rather than being related to general mobility. Janda (1983) also stated that the limitation of postural muscles exclusively to erect standing is, at least from the clinical point of view, incorrect. The basic and primary function of the motor system is "motion" and all static functions should be derived from this basic kinetic or dynamic performance. Therefore the question according to Janda should be raised in an opposite way: not "what is the basic posture of man?" but "what is the basic movement pattern?", and from this, the statics should be derived: in Janda's words "posture follows movement like a shadow".

Another difficulty in identifying postural principles arises from the many varieties of human physique. Thus, no norm of posture can be defined for the "average" person because most of the main static positions possible depend on a plethora of causal factors (Steindler, 1964).

The dearth of conclusive research in this area will probably continue because of the complex interrelated problems of body-type variability, physical anomalies, the need for longitudinal studies and the fact that all people

assume several thousands of dynamic and static postures during the course of a normal day.

Notwithstanding the above, a great need for knowledge related to the efficient use of the body had become a fundamental concern in many daily living activities, and this is carried over into most fields of athletics and sports. This author contends, therefore, that there is value in making efforts to formulate some mechanical principles which apply to most individuals despite differences in body structure.

Efficient body mechanics is emphasized for the purpose of allowing the vital organs to function optimally and to give the body an opportunity to perform its various functions optimally. Hellebrandt (1938) argued that a well-aligned position should require less energy than an unbalanced one. Electromyographic records of muscle function of a young adult female showed less activity in thigh and lower leg muscles when standing in a well-balanced position, than when standing with the pelvis tilted either foreword or backward, and Kendall (1983) argued that minimal muscular energy is expended in anatomically efficient positions.

Chukuka et al.(1986), compared the integrated electromyography of the upper portion of the trapezius in three neck positions and found that tension was significantly greater in a mechanically inefficient "foreword head"

position. Wells and Luttgens (1976) concluded that the skeletal structure should be architecturally and mechanically sound so that there is a minimum of strain on the weight bearing joints, and pressure within the joints equalized.

With regard to balanced alignment of the body, some investigators have considered the importance of muscular function in terms of sufficient flexibility and "muscle tone" (McKenzie, 1981; Adams and McCubbin, 1991; Cyriax 1979) as well as muscle endurance. Garret (1987) concluded that, without muscular endurance, patients may have difficulties in tasks such as standing, sitting or walking for extended periods.

The theories and techniques employed to treat unbalanced alignment and related physical deformities are many and varied. However each shares factors in common with the others and all agree that a modicum of strength, flexibility and muscular endurance, are prerequisites for normal spinal function (Siracusano, 1984) .

#### **THE INCIDENCE OF SCOLIOSIS**

Scoliosis is a lateral deviation of the spine, often associated with vertebral rotation and twisting of the longitudinal axis (Bennetti and Podesta, 1991). It is a general term, used to describe any lateral curvature of the spine. Previous studies of the deformity have shown that it is one of the more common disorders of infants and young

children and the earliest definitive study of the incidence of scoliosis by Shands and Eisberg (1955) included analysis of 50 000 mini-films made for a survey of chest disease in the State of Delaware, U.S.A. These authors determined that 1.9% of the population over fourteen years of age had scoliosis of at least 10 degrees. In that group there was a female to male ratio of 3.5:1.0.

In 1970 Kane and Moe conducted a study in the State of Minnesota, U.S.A., which found an incidence of at least 0.33% for scoliosis severe enough to require referral to an orthopaedist. Their figures were based on all patients with scoliosis who were born in the year 1950. They also found a five-to-one female predominance. These authors pointed out that their criterion for referral to an orthopaedist for evaluation of scoliosis probably resulted in a conservative incidence rate. In a later screening programme instituted in Minnesota, in which 40 241 children in the fifth through tenth grades were screened, "rib-hump" was reported in 6.7% of the boys and 9.12% of the girls (Kane and Moe, 1970). In another prospective study of the incidence of scoliosis it was shown that the deformity occurs in 15% of the school-age population (Brooks *et al.*, 1975).

Different criteria, including variations in sampling techniques and definitions of the deformity, have thus characterized previous studies of the incidence of scoliosis. What emerges, however, is that it is clear that this spinal

deformity is more prevalent than was previously believed, and great strides have been made in the past twenty years in management of the disorder.

A significant difference exists between those "structural" conformations that are true pathologies and functional anomalies which are without bony alterations, and therefore the two great divisions of lateral deviation of the spine are "functional scoliosis" and "structural scoliosis". In general, functional scoliosis may be defined as a relatively fixed lateral curvature, similar to that which a flexible and normal spine may assume when bending to the left or right (Kisner and Colby, 1985). It is a reversible lateral curve that tends to be positional or dynamic in nature. Since there are no structural or rotational changes in the alignment of the vertebrae, correction of the lateral curve is possible by forward or side bending, or by securing positional changes and alignment of the pelvis or spine (Lindbeck, 1985). The curve might also spontaneously disappear when the patient is supine or prone (Piscopo and Baley 1981).

Structural scoliosis, on the other hand, is a fixed lateral curvature of the spine with fixed rotation of the vertebrae. Usually the vertebral bodies rotate toward the convex side of the curve and the spinous processes rotate away from the convex side of the curve (Kisner and Colby, 1985). In this deformity, forward bending of the trunk

produces a posterior rib-hump in the thoracic region on the convex side of the curve because of the rotation of the vertebrae and rib cage. A prominence of the rib cage can also be noted along the anterior aspect of the chest on the concave side of the curve. Associated structural changes of soft tissue in the spine may include lateral displacement of the nucleus pulposus in the intervertebral disc space (Steindler, 1964). Structural scoliosis is classified by its magnitude, location, direction and etiology (Cassella and Hall, 1991). The direction of the deformity is determined by the convex side of the curve. A structural curve is described by both the location of the apical vertebra and the direction. There are various possibilities in the development of scoliosis in terms of the shapes of curves:

A. Long "C" curve:

The "C" curve usually extends the length of the thoracic and lumbar sectors. It is often uncompensated, leading to a high shoulder on the convex side of the curve and high pelvis on the concave side (Figure 1).

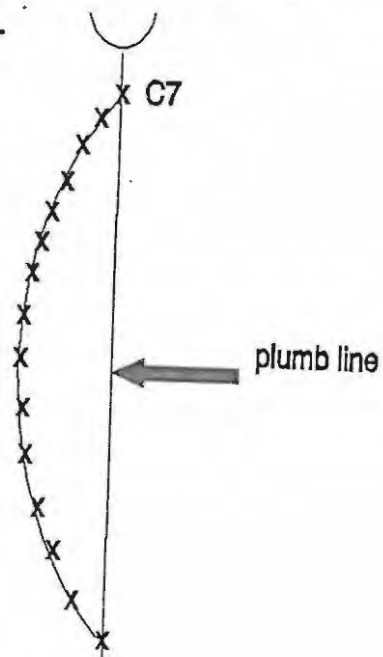

Figure 1: "C"curve scoliosis.

B. "S" curve:

This involves a major curve and a compensatory one (Figure 2). Previous studies have shown that usually this type of deformity is associated with structural changes in the vertebrae of the major curve. In their prospective epidemiological study, Brooks *et al.* (1975), concluded that thoracolumbar curves (S-shape) are the most common type of idiopathic scoliosis. They based their conclusion on examination of 40 241 school children in the fifth through tenth grades.

Structural curves are further categorised as major and minor. An individual's major curve, by definition, is the largest curve and usually has the greatest degree of vertebral rotation of all the curves present. The minor curves are smaller and have lesser degrees of vertebral rotation. Minor curves are more flexible and usually develop to compensate for the major curve (Cassella and Hall, 1991).

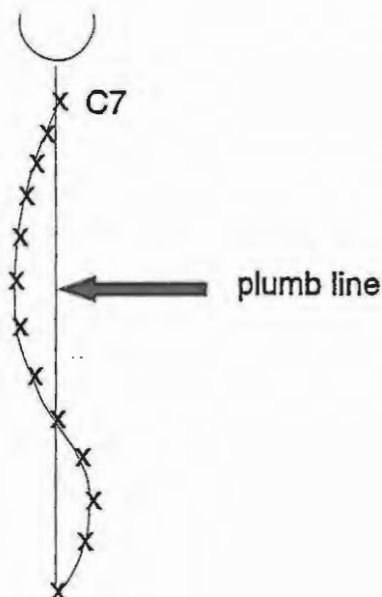
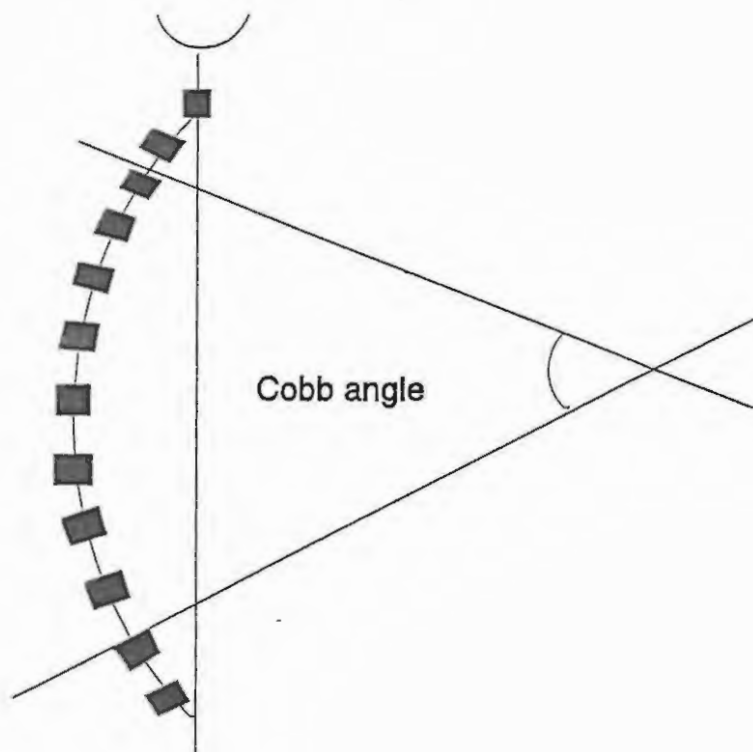

Figure 2 : "S" curve scoliosis.

The Cobb method is the most widely accepted method of measuring curve magnitude. The location of a structural curve is determined by its apical vertebra, which is usually the spinal segment with the greatest degree of rotation (Figure 3). According to the Cobb method of measuring curves, a line is drawn perpendicularly to the upper margin of the vertebra which inclines most toward the concavity. A line is also drawn on the inferior border of the lower vertebra that has the greatest angulation toward the concavity. The angle of these transecting lines constitutes the recorded "degree of curvature" (Basmajian, 1978).



**Figure 3 :** Cobb method of measurement (Cassella and Hall, 1991).

## THE ETIOLOGY OF SCOLIOSIS

A great deal of information characterizing various attributes of the spine is available. Research has provided values for flexural stiffness, axial compliance, range of motion under various loading modalities and considerably more. This study serves as a broad introduction to the behaviour of the spine as a whole. Knowledge of the normal is a basis if not a prerequisite for an understanding of the abnormal. Thus, the present study also describes certain aspects of the biomechanics and kinematics of the normal spine relative to scoliosis. Fundamental concepts and definitions related to the mechanics of scoliosis are also reviewed.

About 80% of all scolioses are idiopathic (Cassella and Hall, 1991). Researchers worldwide have found a variety of abnormalities in tissue throughout the body associated with scoliosis, including peripheral muscle, skin, ligaments, platelet, bone, intervertebral discs, serum and urine (Worthington and Shambaugh, 1991). Scoliosis is evidently a complex disorder in which expression of the defect is variable. Both empirical and analytical methods have been used by many investigators to study the etiology of scoliosis and various explanations have been proposed. Taylor (1983) believes that scoliosis develops due to congenital asymmetry of the ossific nuclei of the vertebrae, thus causing asymmetric growth. Dickson and Sevitt (1982), consider the cause of idiopathic scoliosis to be the same as that of Scheuerman's Disease. They maintain that the type of spine

deformation depends on the location of the pathological process. Thus if pathological changes are localized in the front of the vertebral column, Scheuerman's Disease develops, whilst if the posterior part is defected, scoliosis is caused. Following their study on 26 patients with idiopathic scoliosis, Samuelsson *et al.* (1991) stated that scoliosis associated with syringomyelia may be more common than previously thought and may be wrongly classified as idiopathic. They suggest that a neurogenic cause of scoliosis should always be considered before the beginning of any treatment for the correction of the deformity.

Several studies have demonstrated abnormalities of posture, proprioception, and equilibrium control in patients with adolescent idiopathic scoliosis. Geissele *et al.* (1991), stated that these functions are integrated by structures in and around the brain stem, and studied the anatomy of the brainstem in such patients. Asymmetry in the ventral pons of medulla in the area of the corticospinal tracts was noted in 30% of the patients. These findings may support previous studies that have suggested a nervous system abnormality as a cause of scoliosis.

Other investigators have also concluded that various neurological diseases are frequently accompanied by scoliosis (Schneider *et al.*, 1991). Arkin (1950) concluded that lateral curvature of the spine, with its accompanying distortion of the thorax and body contours, is caused by a play of

gravitational forces upon the vertebral column which, because of its segmented character, is inherently unstable.

Roaf (1966) proposed that scoliosis is caused by soft-tissue constraints (a tether) interacting with unequal growth of the vertebrae. An earlier alternative theory was developed by Sumerville (1952) which proposed that accelerated anterior growth or constrained posterior growth forces the spine into a combination of lordosis, rotation, and lateral deviation. Jarvis et al. (1988), experimented with a posterior tether which they suggested was the mechanism behind the combination of rotation and lordosis. They applied a metal rod or wire to exercise human and calf spines and showed in one case on each species that compression of this construct, caused both a lateral curvature and some degree of rotation of the spinous processes towards the concave side of the resulting curve. Carr et al. (1992) have offered a different description of the etiology of scoliosis and noted that defective collagens are reasonable candidates for the primary abnormality in scoliosis. Worthington and Shambaugh (1991) also noted that primary defects appear to be related to collagen and proteoglycan synthesis. They concluded that the systemic abnormalities seen in idiopathic scoliosis cannot be explained by the biomechanical effect of the curvature. Stokes and Gardner (1991) reported similar findings upon examining a model which represented an isolated ligamentous spine with realistic elastic properties. Three variations of

this model were used to investigate two different hypotheses about the etiology of scoliosis, and to define the forces required to produce a scoliosis deformity. Their first hypothesis was that coupling within a motion segment produces the interaction between lateral deviation and axial rotation. The second hypothesis was that posterior tethering by soft tissues in the growing spine produces the observed interaction. Mathematical modelling of both hypotheses failed to produce the clinically observed pattern of interaction. Therefore, to find which biomechanical forces were required to produce scoliosis, prescribed displacements were applied to the model. According to Stokes and Gardiner, production of a double-curve scoliosis of  $10^\circ$  Cobb angle required lateral forces of the order of 20N acting 40mm anterior to the vertebral centra. The results of this study have led them to the conclusion that since there do not appear to be any anatomical structures capable of producing such forces, it is unlikely that scoliosis deformity can be explained in terms of forces acting on the spine, and understanding of its origins may come from examination of other mechanisms such as asymmetrical thoracic growth or asymmetrical vertebral development. Steindler (1964) had earlier stated that the play of gravitational forces upon the vertebral column can be a possible cause of scoliosis and that the scoliotic spine is one in which the intrinsic equilibrium of the spinal column has been lost since the preservation of such equilibrium would preclude development of the deformity.

With regard to biomechanical factors which might influence scoliosis, Brown (1988) claimed that biomechanical studies of the spine have become an important factor in the clinical management of scoliosis. Such studies are not only interesting for their own sake, in providing basic understanding of the mechanics of curvature, but also are important for the clinical understanding and treatment of the problem.

A dominant consideration which is also clinically relevant in the etiology of scoliosis is the mechanical coupling which occurs when the spine bends laterally. Structural features of the spinal column cause individual vertebrae to rotate about the longitudinal axis of the spine. The spine as a mechanical structure has the vertebrae articulating with each other in a controlled manner throughout a complex system of joints, ligaments and levers. The articulations of the spine are such that when each motion segment moves, it involves several facet joints. During flexion, extension, lateral bending and axial rotation, the vertebrae allow significant amounts of movement, and according to Panjabi (1983) there is a total of 250° of sagittal plane movement, 150° of frontal plane motion, and 180° of transverse plane rotation. However, Panjabi concluded that although it is important to know the total movement of the human spine, it is the relative movements of each functional unit that are important, biomechanically as well as clinically. A composite graph (Figure 4) shows the

ranges of motion of the vertebrae in the three plans of movement (White and Panjabi, 1978).

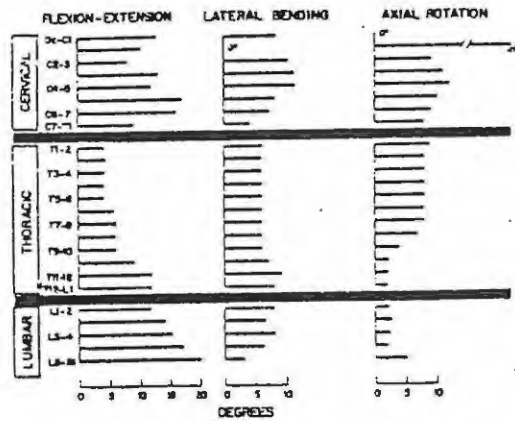

Figure 4 : ROM of the spine (White and Panjabi, 1978).

In flexion\extension, motion in the cervical spine is uniform with a peak at C<sub>5</sub>-C<sub>6</sub>. The motion increases from T<sub>1</sub>-T<sub>2</sub> to L<sub>5</sub>-S<sub>1</sub>. In lateral bending, motion is more or less constant within the entire spine except at C<sub>1</sub>-C<sub>2</sub> where it is nearly zero. At occiput-C<sub>1</sub> the axial rotation is very small while at C<sub>1</sub>-C<sub>2</sub> it is rather large. There is a sharp decrease in this motion in the lower thoracic and entire lumbar spine. A sudden decrease in the rotation range of motion is noted at T<sub>9</sub>-T<sub>10</sub> continuing into the lumbar spine. The functional behaviour of the facet joint is thus demonstrated in that the orientation of the facets determines to a great extent the type of motion allowed. Although flexion and extension remain almost pure in their movement plane during normal motion, Panjabi (1983) states that side flexion and rotation cannot be carried out independently and appear to be directly

coupled. These coupling patterns may be helpful in the understanding of internal derangements that might have taken place in the scoliotic spine.

Various theories have been advanced to explain the rotation movement of the vertebrae in structural scoliosis. According to Steindler (1964), the longitudinal rotation of the spine begins in the intervertebral articulations with the discs as centres. As the limit of rotatory excursion is reached, the rotatory force is transmitted to the vertebral bodies and causes structural changes of torsion. Steindler states that there are two features which particularly reflect this torsional effect. One is the deflection of the arch in relation to the body. It does not follow entirely the convex side rotation of the body but it is deflected against it toward the concave side. The other is the fact that, due to the rotation, the perpendicular trajectories of the vertebral bodies assume a spiral course on the surface. This manifests itself by a twist between the upper and lower plane of the vertebral body, giving its surface a sort of fluting spiral aspect. During the process of spinal rotation the ribs, still attached to the column, undergo deformations of their own (Steindler, 1964). They are "rolled-up" posteriorly on the convex side with the result that the costal angle becomes markedly sharpened and a costal prominence develops. On the concave side, posteriorly, the ribs are "flattened-out". Steindler states that an important element of the deformity is the loss of the normal relation of the dorsal spine to the thoracic cage, because the thoracic cage doesn't follow the

spine on its rotation, but stays behind. Under normal conditions, the spinal column and the thoracic cage move together as one mechanical unit, both in side bending and in rotation. Thus, according to Steindler, in any position the body may assume, the spinal column divides the thorax into two approximately symmetrical halves and occupies the midline between them. In the scoliotic spine, the condition is essentially different. The convex and concave sides are no longer symmetrical, and neither the thorax nor the pelvis rotate commensurately with the spinal column. They stay off the concave side and thereby abandon their normal relationship with the spine. The direction of rotation, combined with side flexion, appears to be the same regardless of whether it is performed in flexion or extension, and this is such that both occur to the same side together, so that in lateral bending, automatically some physiological rotation occurs to the same side, and in rotation, some lateral bending to the same side automatically occurs (Panjabi, 1983). This pattern in the normal spine varies in the three spinal sectors and, to a greater or lesser degree, as a result of the natural structural variations that occur in a given population (White and Panjabi, 1978). According to Panjabi (1983) the coupling patterns in the spine are most strong in the cervical region; rather weak in the thoracic spine; and again, stronger in the lumbar vertebrae.

White and Panjabi (1978) have stated that in the cervical vertebrae between C<sub>2</sub> and C<sub>7</sub> there is a gradual cephalocaudal

decrease in the amount of axial rotation that is associated with lateral bending. At the second cervical vertebra there are two degrees of coupled axial rotation for every three degrees of lateral bending, while at the seventh cervical vertebra there is one degree of coupled axial rotation for every 7.5 degrees of lateral bending.

This phenomenon of gradual change in the coupling ratio may be related to a change in the incline of the facet joints, and although this has not been measured, White and Panjabi believe that the angle of inclination of the facet joints in the sagittal plane increases cephalocaudally. However, following their study, Koreska et al. (1985), argued that the facet joints are not involved directly in the coupling process but serve rather as blocks setting maximum limits for segmental rotation. Arkin (1950) also concluded that the involvement of the soft tissues, muscles, ligaments and structures within the canal and foramina all play a part in the type of movement possible at each level of the spine. Studying the effect of facet asymmetry on these coupled motions, Duncan and Ahmed (1991) observed three different lumbar coupling patterns. However, these did not appear to be influenced by facet joint asymmetry and therefore they also concluded that the facet joints do not affect the coupling patterns. Several coupling patterns have been identified in the lumbar spine and lateral bending without rotation appears to be possible only for small degrees of movement. This is similarly the case for rotation. The

coupling of axial rotation to lateral bending is quite strong in the lumbar region and in fact demonstrates cross-coupling of all three planes of movement. However, movement in the sagittal plane (flexion and extension) does not produce movement in the other two planes, unlike side flexion and rotation.

As has been previously stated, the mechanical coupling of the spine is clinically relevant to the etiology of scoliosis. In a clinical study of coupled motion in non-ambulatory children with Duchenne's Muscular Dystrophy (DMD), Koreska et al. (1985), found that the coupling mechanism is an important aspect of normal as well as of abnormal spinal behaviour. In the DMD patients studied with long term follow-up, a lack of consistent coupling preceded rapid progression of the deformity, leading to structural collapse of the spine. They explain that most of the clinically normal spines have minor defects in coupling behaviour and irregular patterns of segmental rotation in the straight upright position. However, these irregularities involved small segmental rotations when compared to abnormal spines, and were generally in alternating directions from segment to segment. Thus the overall effect of the imperfections was a balanced spinal column. When bending to the left or right the normal spinal irregularities vanished into a consistent pattern of coupling. In the abnormal spines, however, the noticeably larger initial segmental rotations increased with

lateral bending, and coupling was either inconsistent or completely absent.

Loncar et al. (1991), have offered another description of the etiology of scoliosis, focusing on the evaluation of the impact of the adolescent growth spurt on the onset of idiopathic scoliosis. When normal children were compared with scoliotics, it became evident that the latter grew faster. Girls whose scoliosis developed from a previously normal conformation showed a significantly higher peak-height velocity per year, compared to girls with normal spines. Thus, the possibility that rapid growth during the pubertal period can lead to changes in spinal status, should also be considered. However, in a school screening study, Dickson and Sevitt (1982) measured the stature of boys and girls with idiopathic scoliosis and suggested that increased body length was related to the progression rather than to the presence of the deformity. Nicolopoulos et al. (1985), have also investigated stature and its components in scoliosis and found that sex difference in the hormonal control of trunk growth may be linked to the predilection of girls for developing progressive scoliosis during adolescence.

White (1971) concluded that due to increased use of one hand, a slight thoracic curve might occur as a normal response of muscular adaptation. Basing his conclusion on diverse observations, White offered a different explanation to the etiology of scoliosis; that since a slight

physiological thoracic curve are already present, if some precarious balance of the normal thoracic motion should go askew, vertebrae in the physiologic thoracic curve might rotate too much into the convex side. Such an occurrence could set off a chain of events which lead to asymmetrical loads on the epiphyseal plates, muscular and ligamentous imbalances, and ultimately, progression to scoliosis. The precipitating condition could be an abnormal or malaligned facet joint, which might upset the delicate balance of the spine. Goldberg and Dowling (1991) investigated dimensions of hand- and foot- preference in children with scoliosis and children with clinically straight spines and found that there was a statistically significant tendency for children with any degree of asymmetry to show uniform lateralization in the sense of consistency of side preference.

In dealing with the etiology of scoliosis, Irvin (1991) examined the relationship between tilt of sacral base and lateral deviation. The results of his study lead to the suggestion that a tilted sacral base, as viewed in the frontal plane, contributes to lumbar scoliosis and that the use of a heel-lift to level the sacral base in mild cases of lumbar scoliosis can be beneficial. Wagner (1990) found that pelvic tilt is often the consequence of discrepancy in leg length. However, pelvic tilt can also occur independently of uneven leg length in cases of asymmetry of the pelvis, malposition of the hip joint or scoliotic deviation of the spine. In such cases, Wagner also contended that correction

of the unbalanced pelvis should aim a balanced body alignment. Steindler (1964) observed that it is the shape of the fifth lumbar vertebra (L<sup>5</sup>) which determines the changes of the sacrum and the pelvis. If the lower contour of L<sup>5</sup> is obliquely planted into the pelvic ring, then it serves as the keystone of a curve which includes the sacrum as well as the lumbar spine. The pelvis in this case might be tilted downward on the side of convexity of the lumbar curve. Frischhut and Krismer (1990) concluded that severe oblique pelvis and scoliosis can be related to the severity of neurologic dysfunction.

A cause-and-effect relationship between scoliosis and tibiotarsal deformities associated with slipped tendons was found in the work of Droual et al. (1991). Significant positive correlations were observed between lateral deviation of the spine and rotational and bending deformities of the distal tibiotarsus on the convex side of the scoliosis. Pal (1991) generated an hypothesis for the mechanism of production of scoliosis, postulating that vertical stability of the thoracic spine is maintained by equal support through the ribs from both sides due to the equal load brought to the lamina by both the ribs through the costotransverse articulations and ligaments. Any interference in this balancing mechanism would disturb the mechanism of spinal stability and the spine would bend toward the more heavily loaded side at the intervertebral joints. On the basis of this hypothesis, mechanisms of production of scoliosis (both

in experimental animals and humans) after removal of ribs on one side, can be explained. Removal of the ribs from one side produces an imbalance in the symmetrical weight transmission through the ribs on the two sides. Pathological deformation within the vertebrae in scoliosis results from the asymmetrical load and the altered route of the load-transmission of the convex side of the curve. This hypothesis finds further support in the results of an experimental study on rabbits which indicated that scoliosis resulted because of the asymmetry in load-transmission through the ribs to the vertebral column (Pal *et al.*, 1991). Although these results might sound plausible, any explanation of the etiology of orthograde human scoliosis through experiments on pronograde rabbits is dubious. Yarom *et al.* (1978), investigated the paraspinal muscles at the level of the apex of the curvature as well as deltoid, trapezius and gluteus maximus muscles, and determined that all the scoliotic patients who were examined suffered from myopathic changes in the paraspinal and deltoid muscles. Some changes were also found in the trapezius and the gluteal muscles.

Nudelman and Reis (1990) concluded that unbalanced forces acting in the musculoskeletal system may lead to increasing mechanical pressure on certain points of the skeleton, which over time may bring about the deformation of scoliosis. The deformities of idiopathic scoliosis are the lateral bend as previously discussed and a paradoxical rotation of the vertebral column around its vertical axis with the

displacement of its front towards the convex side. In contrast, normal physiological bending of the spine sideways is accompanied by the rotation of the front of the vertebrae to the side of the bend. According to Nudelman and Reis, the points of application of forces to the vertebral column are the points of muscle attachments which are the transverse and spinous processes. However, they noted that the intrinsic spinal muscles are unable to deform the vertebrae as in the case of scoliosis and thus, some other combination of muscle is needed to create the change. Therefore it is difficult to postulate an initial cause-and-effect dependence on one particular group of intrinsic muscles. In addition to the paraspinal muscles, the spine is influenced by powerful muscles attached to the spinous processes and to the limb girdles (Alter, 1988). Such extrinsic muscles are the Trapezius, Latissimus Dorsi and the Rhomboid muscles. These arise from the spinous processes and activate the upper extremities via the scapulae. The Trapezius muscle is attached to the nuchal ligament and to the spinous processes of the cervical and dorsal vertebrae at different angles. The fibres in question are inclined downwards from the cervical vertebrae, horizontally from the upper dorsal and upwards from the middle and lower dorsal vertebrae. The fibres of the Rhomboid muscles slope downwards from the spine. The Latissimus Dorsi muscle arises from the spinous processes of the 7th dorsal down to the 5th lumbar vertebrae. It also arises from the iliac crest. The Pectoral and Serratus Anterior muscles are attached to the ribs on the

anterior and lateral surface of the thorax and to the sternum. According to Nudelman and Reis (1990) this complex of muscles is a triradiate elastic system whose points of actions are:

- A. In the front: the sternum, ribs and clavicle (ventral ray, Figure 5).
- B. In the upper back: the cervical and upper dorsal vertebrae (upper dorsal ray, Figure 6).
- C. In the lower back: the lower dorsal and lumbar vertebrae and the iliac crest (the lower dorsal ray, Figure 6).

With a change in the elastic qualities of any part of this triradiate system, the distribution of forces applied to the points of origin and attachment of the muscles also changes, and that in turn creates an asymmetry of applied forces, and as a result, displacement of the points of attachment (one relative to the other) occurs.

On the basis of the above presentation, Nudelman and Reis explain the biomechanics of the development of scoliosis. The lower dorsal ray of this triradiate system might pull the spinous processes upwards due to unbalanced muscles forces, and might also pull the scapula downwards (Figure 7). The scapula pulls the upper dorsal ray which acts like a bow-string together with the lower dorsal ray. The traction

force of the upper dorsal ray pulls the upper part of the curve to the mid-line, adding to the compensatory curvature.

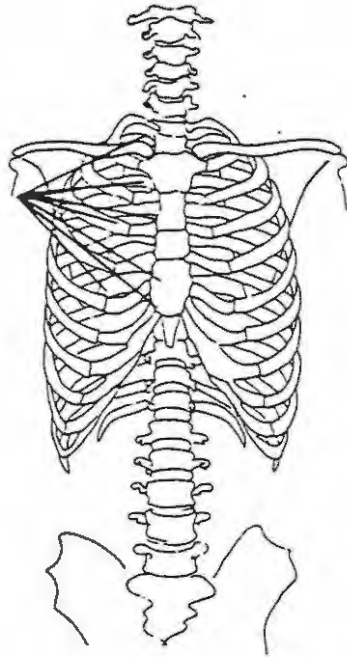

**Figure 5 :** Ventral Ray of the Triradiate System (Nudelman and Reis, 1990).

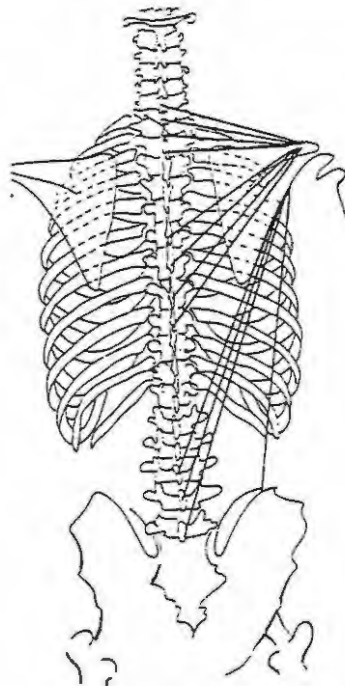

**Figure 6 :** Upper and Lower Dorsal Rays of the Triradiate System (Nudelman and Reis, 1990).

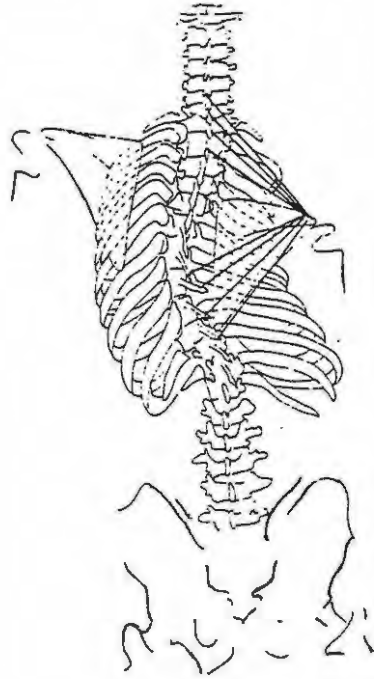

**Figure 7 :** Formation of the thoracic scoliosis (Nudelman and Reis, 1990).

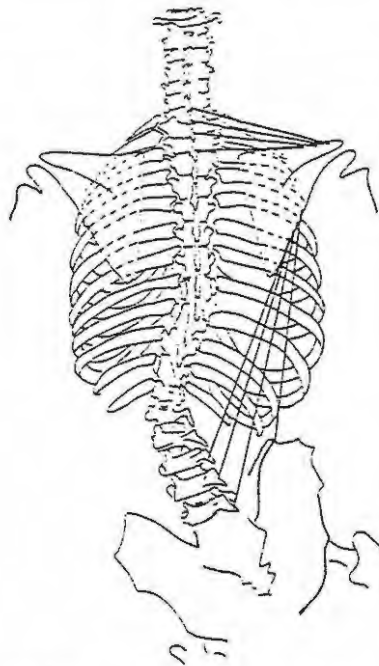

**Figure 8 :** Formation of the lumbar scoliosis (Nudelman and Reis, 1990).

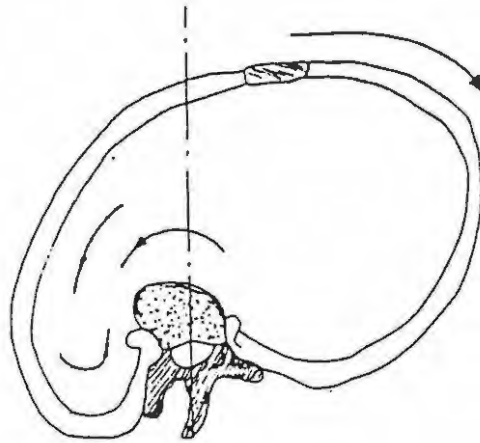

Figure 9 : Forces deforming the chest wall  
(Nudelman and Reis, 1990)

Besides the Trapezius muscle the Latissimus Dorsi muscle can achieve similar results but since this muscle acts on the lumbar vertebrae whose spinous processes are less inclined, their displacement has a lesser lateral tilt. According to Nudelman and Reis this explains why the lumbar scoliosis tends to exhibit shallower curves. Concomitantly with the displacement of the lumbar vertebrae, the Latissimus Dorsi muscle pulls up on the iliac crest (Figure 8). Together with the rotation of the dorsal spine, the thorax also turns in the opposite direction to the pulling muscle, but the ventral ray of the elastic system (the pectoral and serratus muscles) limits the rotation of the thorax. The result of the forces twisting the dorsal spine together with the thorax and the limiting forces of the ventral ray (tending to keep the thorax in its proper place) is the increased curvature of the back part of the ribs of the opposite side sharpening the rib hump (Figure 9). Various attempts have been made to explain the deformity which occurs in idiopathic scoliosis, by

postulating pathological changes in the different elements necessary for the balanced alignment of the vertebral column. However, all agree that early detection is essential for a successful treatment (Torell et al., 1981).

#### THE IMPORTANCE OF EARLY DETECTION AND PREVENTIVE TREATMENT OF SCOLIOSIS

Based on the diverse explanations offered for the generation of scoliosis, many investigations have been undertaken in order to establish a programme of treatment. Less emphasis has been put on research endeavouring to prevent the possibility of the deformity occurring in the first place, by instituting a programme of therapeutic exercises in the earlier functional stages of scoliosis. The traditional medical convention is that if certain structural abnormalities are the causes of the problem, then there is no rational bases for the use of therapeutic exercises, for it is difficult to see how the conditioning or strengthening of the trunk musculature can alter the pathological aberrations which are the concomitants of a structural scoliosis. But many orthopaedic surgeons have had first contact with the scoliotic patient only when the curve is severe, and have not seen the deformity in its earliest functional stages. Yet scoliosis is potentially progressive in most children and most health practitioners are agreed that, if untreated, functional scoliosis might well lead to the development of more severe structural changes (Prujjs et al., 1992).

Winthrop et al. (1956) concluded that a long-standing functional scoliosis may produce irreversible changes and develop into a structural curvature. Many investigators agree that if undetected and untreated during the growth years, any type of scoliosis can lead to severe deformity drastically affecting body function and appearance (Bennetti and Podesta, 1991; Cassella and Hall, 1991; Blount and Bolinke, 1967).

Medical advances have improved greatly the health of the population in some domains. However, it is this author's opinion that the potential for more effective solutions lies in a preventive approach. Efforts to reduce risk factors beginning during childhood can be a significant means of decreasing the incidence of different deformities in the adult years. This can also be done through exercise and muscular balancing.

Scoliosis due to asymmetrical bi-lateral muscular contractions has been studied by Noone et al. (1991). They have stated that there are three factors which contribute to the progression of the lateral curve. These are: abnormally small vertebral body dimensions compared to spinal length, an abnormally flexible spine, and the case where the spine is subjected to abnormal loads through abnormal muscle contraction forces. Schultz (1984) argued that it is this latter factor which has the dominant role. Experimental and statistical findings by Schultz highlighted the potential effect of the trunk muscles in the progression or correction

of scoliosis. Haderspeck and Schultz (1981) also hypothesised that a source of progression of scoliosis is due to the inability of the trunk muscles to provide the appropriate forces to maintain an unchanged upright position of the spine. In the case of paralytic scoliosis, the mechanism is almost certainly due to asymmetrical trunk muscles, as also indicated in the work of Koreska et al.(1985). There is an unbalanced lateral bending moment acting on the spine, the neural control system fails to respond with the appropriate asymmetric muscle contractions required to balance the moment, and hence the spine laterally bends.

Many other authors maintain that muscle pathology is the main reason for curvatures. Low et al. (1983), for example, discovered metabolic changes in the erectors spinae muscles. Ford et al. (1984), found myopathic changes on the convex side at the apex of the curve and extending two vertebrae above and two below the apex. These changes were observed in the deep as well as in the superficial muscles of the back. Sagal et al. (1983), studied the gluteus maximus muscle on the concave side of the curve, as well as paraspinal muscles, and were able to identify myopathic changes. They deduced that scoliosis is a general disease which can be considered initially as a muscle disease. Haderspeck and Schultz (1981) investigated muscle action as a cause of curvature of the spine. It was determined that muscles spanning the concave side of the spine can cause an increase in the curvature.

Thus the external oblique and erector spinae muscles can increase lumbar curvatures. Latissimus Dorsi, intercostal and erector spinae muscles can increase the thoracic curvature. In relaxed upright postures of the trunk in structurally normal individuals, Haderspeck and Schultz (1981) assume that the spinal motion segments are seldom called upon to resist lateral bending moment through lateral tilting. The neural mechanisms controlling trunk posture must sense the existence of any moments on the spine and signal the trunk muscles accordingly. The trunk muscles must then contract appropriately to obliterate spinal lateral moments.

The progression of scoliosis might result from failure of the trunk muscles to continuously balance the lateral bending moments that act on the spine. This might be the result of inability of the neural mechanisms extrinsic to the muscles to sense the moment imbalances or to direct the needed response properly, or intrinsic inability of the trunk muscles to respond appropriately to the neural control signals. Malfunctions intrinsic to the trunk muscles might take several forms: excessively high, bilaterally symmetric muscle tone, unilateral weakness, or side to side differences in contraction force levels resulting from inability to sense contraction intensities properly (Haderspeck and Schultz, 1981).

The paraspinal muscles have been implicated by several investigators as a major causative factor in the production and progression of scoliosis. (Ford et al., 1984; Fidler and Jowett, 1976). Ford et al. (1984), suggested that the underlying cause of the scoliotic curve might be the imbalance in the deep muscles at the apex of the curve. Electromyographic studies have revealed hypersensitivity of the muscle imbalance as a possible causative factor in scoliosis (Basmajian, 1978). Alter (1988) concluded that, although the spine has some inherent ligamentous stability, the major portion of the mechanical stability exhibited is due to highly balanced and developed dynamic neuromuscular structures. Thus, the importance of extrinsic support of the trunk muscles in stabilizing the spine in any given position, is obvious. The key to this structural balance is an equal pull by antagonistic muscles. But when a muscle imbalance is present, the structure being held in place must deviate from normal and as might happen to the spine in functional scoliosis, cannot be returned to permanent balance until the muscle imbalance is corrected. (Figure 10).

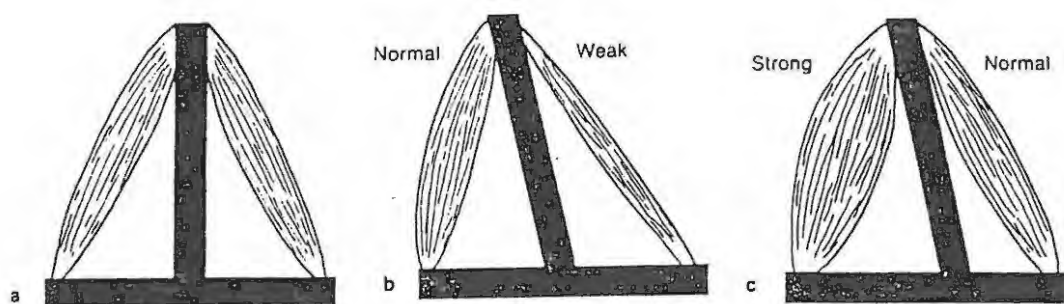

Figure 10 : Muscle balance (Alter, 1988) .

There is substantial clinical controversy regarding the use of muscle forces for the treatment of scoliosis. With regard to muscular function, Wynarsky and Schultz (1991) undertook studies to examine what active muscle contraction forces would be required to produce biomechanically optimal correction of a spine with a scoliotic curve. These studies examined the extent to which scoliosis can be corrected by corrective muscle forces. Their biomechanical analysis showed that muscle balance can produce substantial curve correction. However, they have stated that even under optimal conditions it is unlikely that scoliosis can be fully corrected by active trunk muscle contractions.

A different biomechanical model is presented in the study of Crisco and Panjabi (1991) which compared lateral stabilization potential in the lumbar spine. These authors demonstrated that in any given situation multi-segmental muscles were the most efficient at laterally stabilizing the spine, and that efficiency increased with the number of segments spanned. The most efficient muscles were those that originated from the pelvis, spanning the maximum number of segments. In this work it was shown that the muscular model was unstable when any vertebral segment was devoid of muscle and, moreover, that when the load on the spine is increased, buckling can be prevented most efficiently with the pelvic muscles. These findings explain something of the importance of the muscular system in stabilizing the spine.

Mcgill (1991) analyzed the lower back during complex, dynamic postures, and demonstrated the force and torque contributions of approximately 50 laminae of various trunk muscles to flexion-extension, lateral bending, and axial twisting torque in the lumbar vertebrae. Various portions of erector spinae were observed to have appreciable potential to generate torque about all three orthopaedic axes. This observation also supports the notion held by other therapists, that conditioning of the erector spinae is of utmost importance. To the extent that this is so, it makes sense to address the problem of scoliosis in its earlier stages, by combined treatment of life-style changing and therapeutic exercise prescription. This may well reduce the suffering of the child resulting from bracing equipment that acts to restrict the body and disturb normal life. The importance of preventing the mild forms of scoliosis has been stressed by many investigators and some of the benefits of early exercise treatment have already been addressed. Although it is by no means a panacea, it very well may enable some individuals to assume a more active and enjoyable life.

Another important clinical finding concerns the response of scoliotic patients to treatment by electric stimulation of their trunk muscles. It has been reported that curve corrections result when appropriate trunk muscles are stimulated through external devices (Anciaux *et al.*, 1991; Herbert and Bobeckko, 1985). This indicates that the trunk

muscles do have the inherent ability to correct the lateral spinal curves.

Skeletal maturation is marked by an orderly and reproducible sequence of recognisable changes in the appearance of the skeleton during childhood. But the main problems of the mal-aligned spine in the frontal plane (lateral deviation) are the changes which might occur in the vertebrae themselves, or in costovertebral articulations and, eventually, rib morphology. Nearly half a century ago Arkin (1950) noted that habitual positions of lateral flexion of the trunk produce pressures on the convex side of the spine, which might have a deforming effect on the thorax. According to Steindler (1964), as the deformity progresses, some morphological changes of the vertebrae might occur:

- a. The concave side becomes lower than the convex.
- b. In some cases there is a distortion in the frontal view, the normal rectangular contours being changed into a rhomboid under the effect of side-shift.
- c. Constant pressure of the ribs backward against their transverse processes in time causes the latter to be deflected backward, producing an increase in the length of the pedicle. Frequently, torsion of the body of the vertebra takes place, causing asymmetry of its upper and lower surfaces and sometimes the spinous processes deviate from the mid-line because of unequal

muscular and ligamentous tension on the two sides of the vertebra.

Smith et al. (1991), described structural scoliosis as a complex three-dimensional deformity associated with changes in the shape of the spine in the sagittal, coronal, and transverse planes, and emphasised their studies on the asymmetry of scoliotic vertebrae in the transverse plane. To study the transverse plane aspect of scoliotic vertebrae and to examine their growth, Smith and co-workers used human skeletons with a scoliotic deformity and identified a consistent pattern of intravertebral rotation. Their studies confirm that the transverse plane vertebral deformity of scoliosis is more than simple rotation and that structural deformity of the vertebrae themselves occurs in this plane. These alterations are complex and include changes in the size and shape of the posterior elements and spinal canal in addition to the shape of the vertebral body. The normal axis of rotation of a vertebral segment is governed, according to the above authors, by the angle of the local facet joints. In a normal thoracic vertebra, these produce an axis of rotation in the vertebral body. The pedicle on the convex side of the curve is compressed and responds according to Wolff's law by becoming strong and stout. In contrast, the pedicle on the curve's concavity is unloaded and becomes attenuated.

The deformity of the vertebral body is more difficult to explain. Smith et al. (1991), show that two factors act in

opposition. Although the rotation of the scoliosis turns the whole vertebral body toward the curve convexity, in contrast, there is active growth of the whole vertebra in the opposite direction producing bone drift toward the curve concavity (Figure 11).

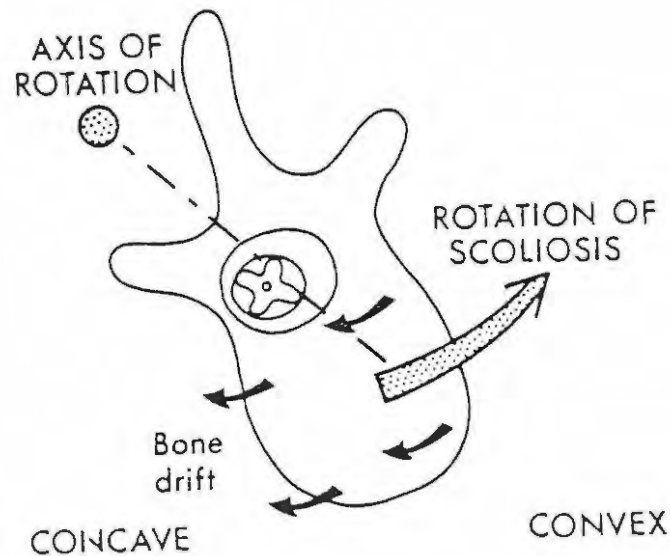

**Figure 11 :** The pattern of growth of a scoliotic vertebra. There is drift of the whole vertebra toward the curve concavity in contrast to the direction of the vertebral rotation (Smith *et al.*, 1991).

According to these authors this bone drift can be explained by considering the mechanics of the column as a whole. The vertebrae are growing maximally where the column is under the greatest longitudinal stress, along its concave surface: moving away from the apex of the curve, the changes are less marked. Beyond the neutral vertebrae, the changes in the pedicle are reversed, the stouter pedicle being on the concave side with reference to the primary curve, These

vertebrae are in segments of the spine that are returning to their normal alignment and compensating for the apical deformity. Their loading is reversed compared with the apex, producing opposite changes in spinal shape by reversal of the same mechanism. Clarity with respect to the changes in vertebral growth demonstrated in the work of Smith et al. (1991) is fundamental to an understanding of the mode of development of spinal deformities. This is essentially simple and follows basic principles of mechanics and the long established "laws" of bone growth and remodelling. It is now conceded that the nature of these bony changes is structurally induced by Wolff's law, which governs the functional adaptation of bone (Pugh, 1983).

Following their studies on osteoporosis and bone dynamics, Martin et al. (1986), concluded that mechanical stresses in bone are carried, not by the bone cells themselves, but by the extracellular matrix which they produce. The dynamic nature of this matrix had been observed since the time of Galileo, but it was Wolff (1892) who applied "the form follows function" argument to bone. This reorganization of bone, after prolonged changes in applied loads, can be observed in many situations, one of which is the condition of disuse. The rapid loss of bone in individuals subjected to weightlessness or various types of immobilization has been well documented and averages about 4% per month for trabecular bone and close to 1% for cortical bone, though the variance is large (Mazess and Whedon, 1983).

Limb casts after injuries resulted in an 18% loss of bone mass (Andersson and Nelsson, 1979). Paraplegics and poliomyelitic patients suffer serious bone loss and degeneration, resulting from muscular inactivity (Brighton *et al.*, 1985). On the other hand, bone formation demonstrated a similar dependence on mechanical stress. Unusual stresses on growing bone show that its shape and size may be much less under genetic control than is generally appreciated. Asking whether a particular bone has its characteristic shape because of genetic design or is simply the optimal shape for its functional requirements, Houston (1978) brings a case of congenital absence of the tibia, from the University Hospital in Saskatoon U.S.A, which provided dramatic insight into this question. At the age of two, the infant's fibula was surgically centred and by age three and a half, radiographs showed that the fibula had assumed the size, shape and cortical thickness of a normal tibia; a classic example of Wolff's law.

Animal studies provide strong support for the role of regular weight-bearing activity in increasing bone mass. Enforced exercise regimes in at least seven different species resulted in both increased bone mass and cortical thickness (Martin *et al.*, 1986). In another experiment, rabbits had one hind limb subjected to an impulsive load by means of a motor driven cam, while the opposite leg served as control. Bone changes were induced in the experimental limb as early as four days into the experiment (Pugh, 1983). Case studies

involving paralysis, injury, amputation, neurological damage and other forms of musculoskeletal problems, exemplify Wolff's law, which states that bone subjected to mechanical stresses, changes its shape and mass accordingly. In other words, the law states that changes in the function of a bone are followed by certain definite changes in its internal architecture and secondary alterations in its external configuration (Davis et al., 1965). It is clear, then, that bone has an ability to adapt to stresses placed upon it.

In conformity with Wolff's law, bone remodelling and osteophyte formation which might occur in advanced stages of scoliosis deformity may alter the joints of the spine to the point where they are much different from the original pre-scoliotic condition. Thus a model based on Wolff's law in terms of bone remodelling in response to changing dynamic loads can explain the risks due to the progression of scoliosis.

The human spine is constantly governed by mechanical principles. The principles of statics, or stability, when it is at rest, and of dynamics, or motion, when moving. Of all the bony structures of the human body, the spinal column plays a unique role in that it serves as a sustaining multi-segmented rod for maintenance of the upright position in a gravital environment. As such it is subjected to a complex system of forces and stresses of a wide variety of types. The pressure to which any given part of the spinal column can

be exposed without it suffering damage is naturally limited. It is therefore essential from a safety standpoint that the area of support of each vertebra be optimal. The average pressure is decreased whenever the area of support is increased. When the sums of forces and of moments acting upon each vertebrae are equal to zero, the spinal column is in equilibrium. In the scoliotic spine, due to the decrease in the area of support, the pressure on some parts of the vertebrae is increased and, as has been discussed, structural changes in the bone might begin to develop. Since the main soft-tissue structures which maintain the stability of the body are muscles and ligaments, we can also assume that any deviations from the midline of the balanced spine might cause uneven tension to be thrown on the ligaments and result in uneven tonus in opposing muscles groups. This might cause fatigue, if not actual strain. Enoka (1988) explains that when the muscles are called upon to bring the segments into vertical alignment, the work required becomes greater as the angle between the segments decreases. This is illustrated by a comparison of the amount of force required to hold a broom by one end, vertically, with that required to hold it horizontally. This is because the length of the resistance arm of the involved levers increases from the vertical to the horizontal position. Consequently, a position of vertical alignment of the vertebral body segments is more economical of energy expenditure than one in which the segments are in a "zig-zag" relationship.

In many patients a mild idiopathic scoliosis will remain stable if left untreated. In others, the severity of the lateral curves will progressively increase. It is not yet known under what circumstances one or the other of these occurs. Haderspeck and Schultz (1981) investigated what kinds of loads could be developed internally to make lateral curves tend to increase. The general goal of their studies was to determine what factors can cause a mild idiopathic lateral curve in a spine to get worse. From a biomechanical viewpoint, a scoliosis may tend to get worse because the spine is too slender, because the soft tissues of the spine allow excessive lateral flexibility, or because abnormal loads continuously act on that spine. Haderspeck and Schultz examined the last factor: what mechanisms could plausibly be sources of lateral curve progression resulting from abnormal loads? According to these investigators, the abnormal loads of concern in scoliosis must be unbalanced lateral bending moments, since compression alone on a motion segment does not cause a significant lateral tilt. When unbalanced lateral moments are imposed on a spine, its involved motion segments will take on lateral tilts. They concluded that even small imbalances in lateral bending moments must be continually resisted by lateral tilts of spinal motion segments, and soft-tissue growth and remodelling processes eventually will translate these small lateral tilts into the large structural lateral deformities seen in the advanced stages of scoliosis.

On the basis of the previous discussion it can be claimed that the treatment goal in cases of functional scoliosis should be to prevent moderate curves from becoming severe, because severe curves in adults may not only cause significant cosmetic deformities but also may lead to serious medical and physical complications. Early detection, through school screening programmes, might also lead to successful non-operative management of idiopathic functional scoliosis.

#### THE EVALUATION OF SCOLIOSIS

Lateral curves of the spine are often first noticed by parents and are sometimes detected by paediatricians during routine physical examinations. The majority of lateral curves, however, are detected in school screening programmes such as those which began in the 1940's and have become widespread in the United States, Canada and other countries. These programmes are usually conducted on children aged 8-16 years, because earlier studies showed that this is the age group of highest risk for adolescent idiopathic scoliosis (Cassella and Hall, 1991).

In their preventive medicine programme for school age children, Bennetti and Podesta (1991) used as clinical method the "Bending Test" that appraises limb asymmetry and rib hump. Following this test, subjects suspected of scoliosis were examined again by an orthopaedic surgeon in order to

decide whether to take radiographs and to define, if necessary, treatment.

However, one of the major factors limiting our understanding of the relationship between treatment and improvement of spinal deformities is the lack of easily administered valid and reliable measures of spinal function and habitual activity. Patients with scoliotic deformity can be evaluated from a biomechanical viewpoint by measurement of spinal morphology, back surface topography and changes in these measurements, both acutely and over time. According to Stokes (1991), these measurement techniques can provide information on spinal deformity and also give further insights into the treatments needed. However, biomechanical evaluations are often done in a nonstandardized manner, which makes it difficult to compare the results of one researcher with those of another.

The scope of available biomechanical techniques can be broken into three main areas. First, there are many methods for recording and quantifying the "shape" of a patient. Second, measurements of change of shape quantify motion and flexibility, or, over a period of time, detect change or progression of the truncal deformity. Third, there are measurements of the forces generated within the musculoskeletal system and of external forces applied to the body. Stokes (1991) stated that these forces can be responsible in the short term for producing motion and change

of shape, and in the long term may also contribute to the pattern of growth and development of the skeletal system. However, it is usually impossible to measure the forces that are directly active on the spine, without the aid of mathematical models which help to translate the physical measurements that are possible, into the force needed to be measured.

As previously stated, the standard clinical measurement of scoliosis is the "Cobb angle" measured directly on a radiograph. However, radiographs are costly as well as time consuming and are not without health risks. Thus a non-roentgenographic method of measuring spinal deviations can be an excellent clinical and research tool, specially when dealing with assessment of exercise or bodily adjustment, attempting to decrease a patient's scoliosis and improve spinal function. During the last few years, some different techniques for noninvasive analysis of human back shape have been proposed (Murphey et al.,1992; Stokes,1991; Kojima and Kurokawa,1992; Slupsky et al.,1992; Capasso et al.,1992). The primary goals of such techniques have been to make large screening safe and to follow up patients more frequently without increasing x-ray exposures. Assente et al.(1987), presented the AUSCAN (Automatic Scoliosis Analyzer) for the evaluation of spinal deformities, which creates a 3-D description of the body geometry with the load distribution during standing (Figure 12).

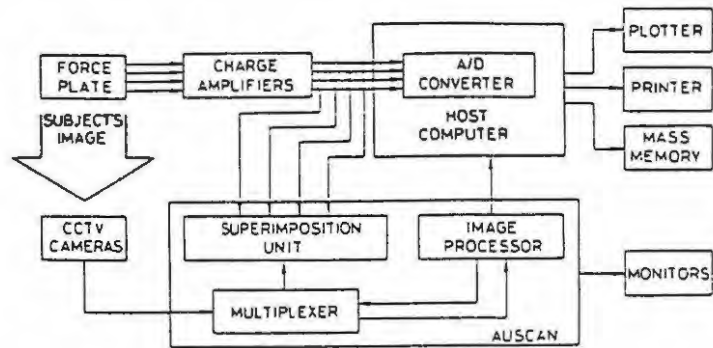
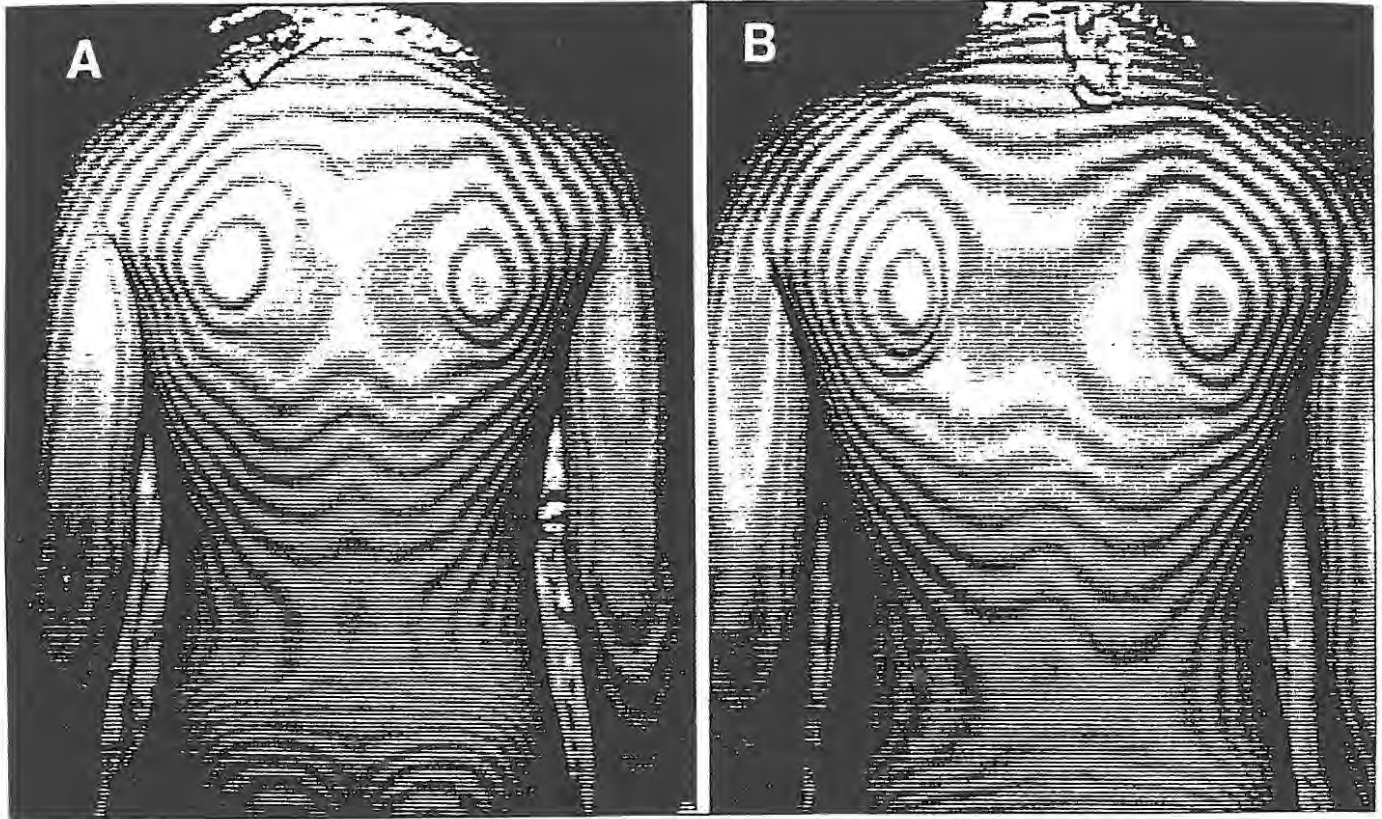

Figure 12 : AUSCAN System (Assente et al., 1987)

Surface shape measurements or topography have also been used by various investigators to record the scoliosis deformity. Recently, Moire' fringe topography has become popular as a non-invasive method for recording the back surface, and showing whether it is symmetrical. In the shadow method (Figure 13) light is projected through a grating next to the patient's back and viewed from a different direction to produce interference fringes. The resulting image can be quantified by counting fringes or by measuring the inclinations of lines drawn between fringes of equal order.



**Figure 13 :** Moir'e topography; (a) relative symmetric contour; (b) asymmetric contour (Cassella and Hall, 1991).

The Integrated Shape Investigation System (ISIS) is another alternative to roentgenography which has made it possible to monitor children with scoliosis without exposing them to unnecessary radiation. It is a non-invasive, automated stereophotogrammetric technique that utilizes computer imaging and measures contours in the transverse, frontal and sagittal planes (Figure 14).

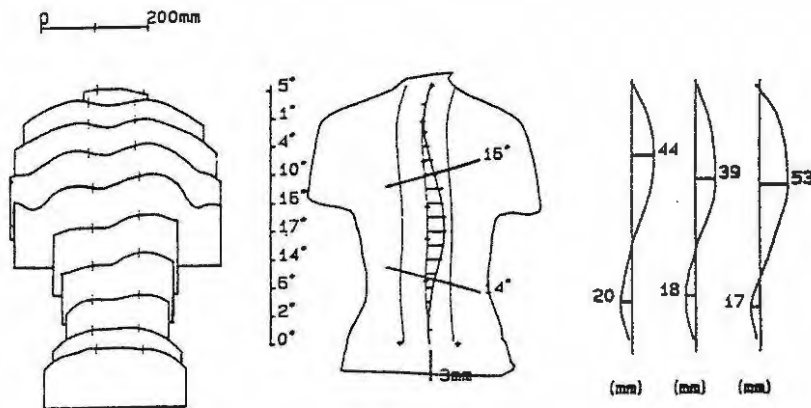

**Figure 14 :** Integrated Shape Investigation System (ISIS). Contour patterns of a patient with a right thoracolumbar scoliosis. (Cassella and Hall, 1991).

To date, very little research has addressed the accuracy of these visual evaluations as compared to radiographic measures. Thus, the therapist should not design treatment plans based only on visual inspection of body malalignment. The results of specific examination procedures, testing joint mobility as well as muscle length, strength and coordination are required to design and implement the appropriate therapeutic programme.

A review of the literature shows much variation in the actual method of measuring children with scoliosis. Cassella and Hall (1991) suggest that prior to the initiation of any treatment programme, the patient should undergo a comprehensive assessment which includes the following measures:

1. Inspection of the patient's natural, relaxed standing position in anterior, posterior, and lateral views.
2. Leg-length measurement from the anterior superior iliac spine (ASIS) to the medial malleolus of the tibia. This measurement is used to determine the presence of leg-length discrepancy which could affect body alignment.
3. Range of motion (ROM) with emphasis on areas that could have a negative effect on the alignment of the body such as the hip flexors, hamstrings, low back muscles and trunk and shoulder girdle.
4. Muscle strength with emphasis on the abdominal musculature.
5. Breathing pattern, especially if the patient has a history of respiratory disorder.
6. Functional activity levels to establish a baseline of the patient's ability in various activities of daily living.

Procedures used by clinicians to evaluate scoliosis often include examination of the positions of the ilia to determine the symmetry or asymmetry of the pelvis. The position of the pelvis is important to consider because many problems associated with lateral deviation of the spine may affect its position. Smith et al. (1988), used a sliding pointer to measure the positions of bony landmarks in relation to the floor and a stationary base ("posture

board"). Three measurements of the anterior superior iliac spine (ASIS) and the posterior superior iliac spine (PSIS) were made as follows (Figure 15):

- a. The vertical distance to the floor.
- b. The horizontal distance to the back of the posture board.
- c. The horizontal distance to the nearest side edge of the board.

In measuring patients with lateral deviation of the spine Brooks *et al.* (1975), collected data in the following categories:

- a. Biographical, including sex, age, weight, height, race and family history of scoliosis.
- b. Medical and surgical history of scoliosis.
- c. Physical signs, including rib hump, lumbar hump, spinal imbalance and discrepancy in shoulder height.
- d. Roentgenographic findings including site, size and extent of curve as well as criteria of spinal growth. The criteria for the existence of scoliosis in their study included the presence of at least one positive physical sign of scoliosis with a minimum curve of 5 degrees (Cobb) as measured on the anteroposterior roentgenograph.

(a)



(b)

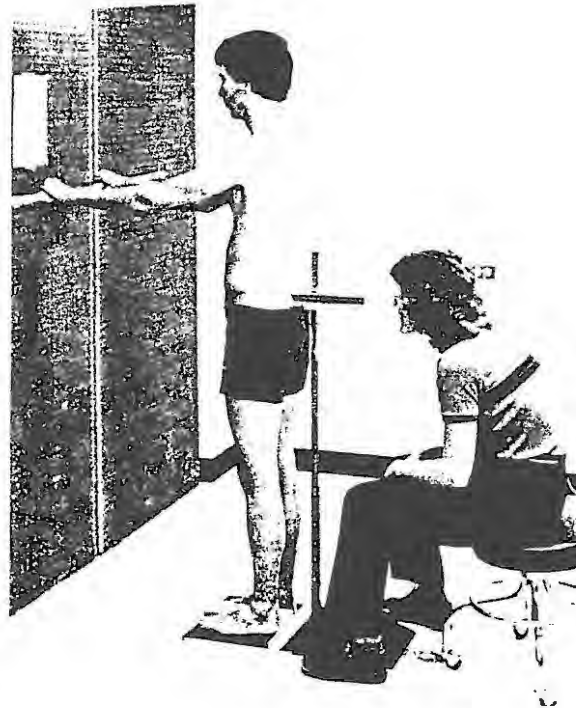

**Figure 15 :** Measurements of bony landmark positions.(a) measurements of the ASIS.(b) measurements of the PSIS. (Smith et al., 1988).

Kisner and Colby (1985) suggested that in evaluation of scoliosis, the following procedure should be used:

1. Anterior, posterior and lateral assessments of the spine, with the use of plumb line to note any deviations in alignment.
  
2. If a lateral curvature is noted, they suggest using the following tests to detect any early structural changes:
  - a. Lateral bending test, to determine whether the curve corrects or reverses as the child side-bends, toward the convex side of the curve. According to Kisner and Colby, asymmetrical side bending might be an early sign that structural changes may have already begun to develop in the spine.
  
  - b. Forward bending test, to determine whether the curve straightens out as the child bends forward, and to identify a visible rotational deformity of the rib cage. If structural changes are present, a posterior rib hump might be seen on the side of the convexity of the thoracic curve, when the child bends forward (Figure 16).

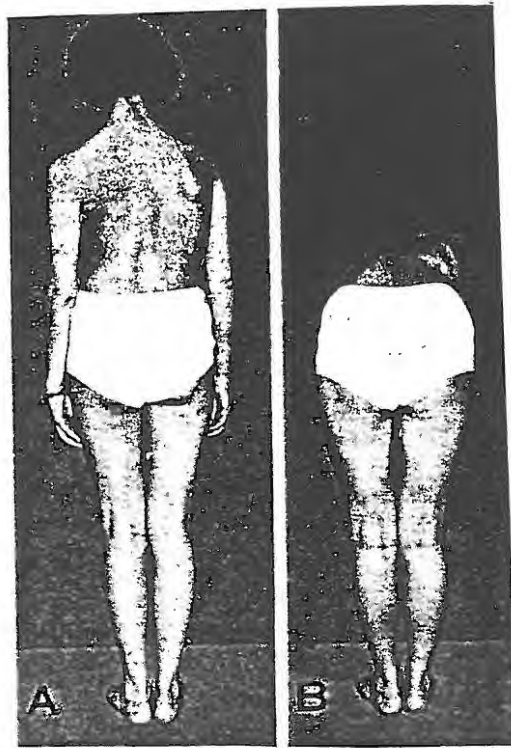

**Figure 16 :** Forward bending test. The rotation of the vertebrae and ribs is most readily detected as the subject bends forward, and a posterior rib hump can be seen on the side of the convexity (Salter, 1988).

In the lumbar spine, prominence of the erector spinae muscles may also be evident on the side of the convexity, due to the posterior rotation of the transverse processes of the vertebrae on the side that pushes the muscles outward (Steindler, 1964).

- c. Evaluation of muscle strength, with emphasis on the abdominal and trunk extensor muscles.
- d. Morphostatic examination in various positions, which is an important factor in the evaluation of any case of scoliosis since some functional spinal

deviations are directly related to habits constructed by the individual in the course of their daily activities.

e. Relating diagnostic information including medical history and x-ray series if needed.

Occhipinti et al. (1989), have described and validated a method for the clinical and functional examination of the spine. Using a scoliosometer, they observed asymmetries of different reference points such as shoulders, ASIS, lateral deviation of C<sub>7</sub> and more.

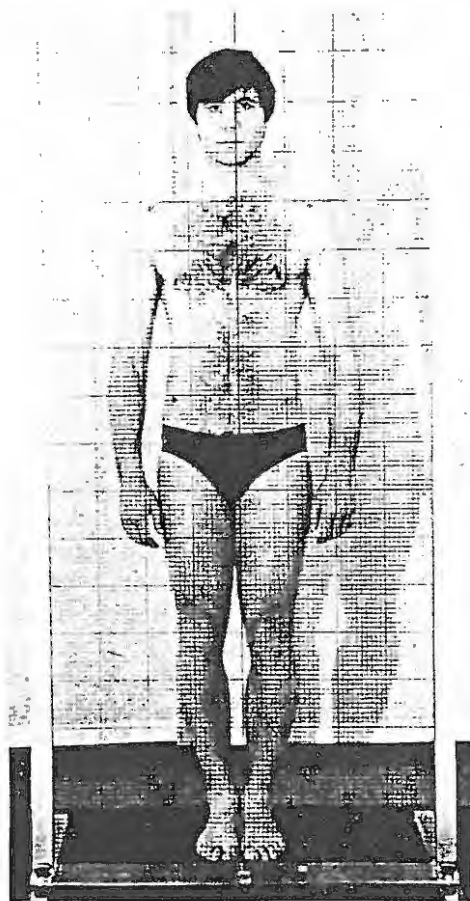

Figure 17 : Frontal plane behind the scoliosometer. (Occhipinti et al., 1989).

The examination model used also consisted assessment of spinal mobility in extension, flexion, lateral inclination (side-bending) and rotation, respectively, for the cervical and thoraco-lumbar regions. The right and left lateral inclination angles were calculated using the parameters of height from C<sub>7</sub> to bed surface in a seating position (Figure 18), and the height from C<sub>7</sub> to bed surface with patient bending right and left (Figure 19).



**Figure 18 :** Measurement of distance between C<sub>7</sub> and seating plane with patient upright seated position (Occhipinti et al., 1989).



**Figure 19 :** Measurement of distance between C<sub>7</sub> and seating surface with patient bending sideways (Occhipinti *et al.*, 1989).

Skeletal maturity assessment is also frequently requested as part of the evaluation of children with scoliosis. As previously addressed, skeletal maturation is marked by an orderly and reproducible sequence of the skeleton during childhood. Such changes include the timing and sequence of the appearance of the centres of ossification, specific alterations in the contours of the bones, and the timing and sequence of the ultimate closure of the growth plates. Radiographic assessment of skeletal maturity in the child is most frequently based on the appearance of the hand and wrist. Such assessment can also be useful in planning orthopaedic procedures in which the outcome may be influenced by subsequent growth of the child.

Several authors have reported large variations in the accuracy and reliability of spinal function measurements. Many attempts at standardization of measurement of spinal

motion have been made and various methods used. However, until a reliable, readily available measure of scoliosis is shown to have high validity compared to radiographs, clinicians will probably continue to use visual assessment and subjective definitions of lateral deviations in patients evaluation.

#### **THE ROLE OF EXERCISE IN THE TREATMENT OF SCOLIOSIS**

Many different types of exercise programmes for spinal disorders have been advocated and the popularity of a given type of exercise programme has waxed or waned without apparent reliable scientific data. In reviewing the literature, one finds many different types of exercise programmes available for clinicians and therapists to prescribe for their patients with spinal disorders, such as flexion and extension exercises, active and passive exercises, and postural exercises (isometric and/or isotonic) (Ponte *et al.*, 1984; Kuprian, 1982). What specific type of exercise programme one should choose and whether it has reliable scientific data to support claimed effectiveness are questions on which available information is often lacking. Perhaps one of the most common problems faced by clinicians and therapists has been their inability to establish specific differential diagnoses based on specific pathologic conditions among many different causes of idiopathic spinal disorders. In the process they attempt to apply one specific exercise programme to all types of spinal problems.

Designing and prescribing exercise programmes for the treatment of scoliosis is a difficult task that requires consideration of several factors. In general, knowledge of the various causes of this deformity is required as is an understanding of the role of exercise in treating these afflictions. More specifically, the therapist must be able to select accurate and reliable tests of functional capacity in order to identify the specific exercise needs of the patient. Based on these needs, exercise should be selected and recommendations made with respect to the frequency and extent of these exercises. Once selected, follow up measures are needed to evaluate the effectiveness of the programme. In 1905, a complete system of exercise therapy for scoliosis was devised by Rudolf Klapp, and his method of creeping exercises is still in vogue and considered effective (Basmajian, 1978). Lovett was a strong supporter of the use of exercises as part of the treatment of scoliosis and devoted an entire section of his 1907 text to the appropriate role of exercises. Licht (1965) wrote an extensive review of exercise for functional scoliosis and stated that the aim of exercise therapy in functional scoliosis is not to develop muscular forces to straighten curves, but to select an initial position to make them disappear. The object, according to Licht is to avoid the reappearance of the deviation in the standing position. The studies of Gustavsen (1985) showed that a specific training programme can objectively improve both functional qualities (muscle endurance, coordination and range of motion) and overall

alignment in students with lateral asymmetries. Denner et al. (1990), have also treated children with lateral asymmetries of the trunk by exercise therapy, with good results. Miyasaki (1980) found that thoracic flexion exercises had a positive influence on vertebral position and were effective in reducing vertebral rotation and lateral deviation in the scoliotic spine. He also concluded that the key to a positive prognosis and correction of scoliosis is early detection followed by initiation of treatment, while the curve is still small. His treatment programme consisted of general conditioning exercises and specific corrective exercises to be performed daily. Basmajian (1978) also stated that upon discovering a curvature, treatment must be immediately considered, in which exercises are recommended. The purposes of therapeutic exercises according to Basmajian are to:

- a. Improve body alignment.
- b. Increase strength of abdominal muscles.
- c. Increase flexibility (elongate the concave aspect of the spine and elongate soft tissue constrictures) .
- d. Correct muscular imbalance.
- e. Improve respiration.

Kisner and Colby (1985) agreed that following the evaluation of the scoliotic patient, a therapeutic exercise programme should be started. However, the study of Stone et al. (1979), showed no significant difference in change of

scoliotic curves, after a 9-month exercise programme. The present study contradicts the notion that exercise has no effect on change in curvature in patients with scoliosis and suggests compelling reasons why the exercise regimen and method of instruction and follow-up used by Stone *et al.*, had no effect on change in scoliosis in their specific group of patients.

Some of the positive benefits from participating in an exercise programme for scoliotics have already been addressed. However, the role of therapeutic exercise in the treatment of this problem remains controversial and a great deal has yet to be learned regarding the relationship between physical activity and lateral deviations of the spine. As our understanding of the etiology of functional scoliosis is improved, the probability that exercise may provide some protection against it might likely be increased, and some of the many biological changes that are produced by exercise may favourably alter the underlying pathology of scoliosis or the body's capacity to adapt to this problem.

## CHAPTER 3

### EXPERIMENTAL METHODS AND PROCEDURES

#### INTRODUCTION:

The need to develop objective methods for determining spinal functionality has been a major concern in rehabilitation, biomechanics, and other related research areas for several decades. Because of the growing need for better standardization and control of therapeutic exercises for various conditions, not only in clinical but in research settings also, development of rigorous measurements and evaluation has become necessary.

The idea of treating patients with spinal deviations by preventive exercise programmes is not new. This chapter examines the parameters of scoliotic spinal function before and after a 20-week therapeutic programme. All testing was done in the Orthopaedic Rehabilitation Unit of the Department of Human Movement Studies at Rhodes University.

#### PILOT STUDY

The aim of the pilot study was to examine the incidence of functional scoliosis among prepubescent children in selected schools in Grahamstown, South Africa, and to explore various measurement procedures in an attempt to determine which tests could be used in the experiment. The aim was to standardize positioning the subjects, instrument placement and

instruction commands. In order to follow through with the study, it was necessary to communicate with school districts that were receptive to such a screening and therapeutic programme. This study reports the incidence of scoliosis as well as the variations in the scoliotic angles of subjects drawn from a population of 1052 children aged 7-18 years.

#### **SCREENING PROGRAMME**

The first stage of the examination was conducted with the children separated into groups according to age and sex. Examination included inspecting the back from behind with the subject standing and then bending forward (Figure 20). A subjective assessment of asymmetry of the upper chest, mid chest and lower chest, the lumbar region and the sacrum, was made in this position.

#### **Parameters observed:**

Physical signs were noted, including rib hump, lumbar hump, spinal imbalance, pelvic imbalance and discrepancy in shoulder height, the yardstick, while subjective, was based on the author's training as an exercise therapist.

Parents of those subjects observed to have positive physical signs were brought by the author to the Rehabilitation Clinic to view at first hand further evaluations and to discuss recommendations regarding treatment.

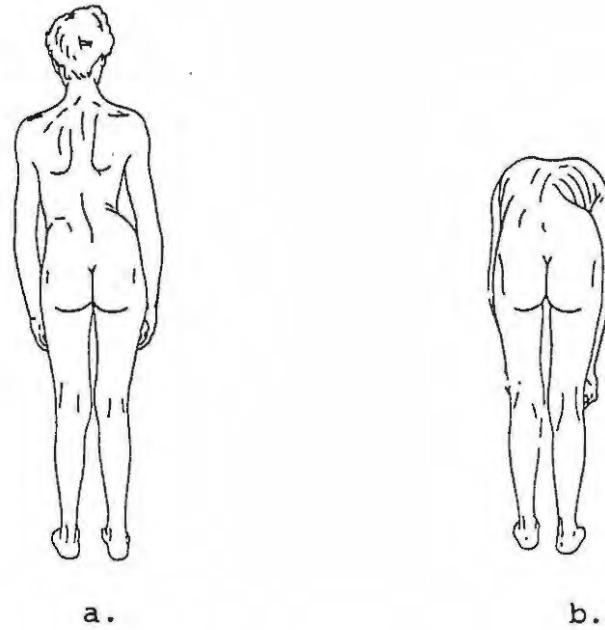

**Figure 20 :** Examination of the spine from behind. (a) Start position. (b) End position with the subject flexing the trunk (Gustavsen, 1985).

**Subject selection:**

Ten scoliotic subjects (7 boys and 3 girls) were examined. Basic data relative to this group are presented in Table I.

**TABLE I :** Physical characteristics of subjects.

	$\bar{x}$	SD
AGE	10.60	2.332
MASS (kg)	31.20	5.64
STATURE (cm)	139.66	10.34
COBB ANGLE	11	5.8779

Because the incidence of scoliosis has been found to be highest in the pre-adolescent years (Brooks et al., 1975), this study was restricted to children at this developmental

stage. Prior to the experiment, informed consent for examination was obtained in writing from the parents of the children targeted for the study. Permission was obtained through a letter (Appendix H) stating the intentions of the examination and of the therapeutic programme, and indicating the importance of early detection of scoliosis. The instrument of consent was approved by the Department of Human Movement Studies, Rhodes University for use in human subject research. Written permission to engage in the therapeutic exercise programme was also obtained from each subject's medical practitioner.

#### Clinical examination

In many cases the decision to implement treatment or to subject a patient to more sophisticated forms of testing was made on the basis of a clinical measurement or observation. The accuracy and precision of clinical measurements is thus not without consequence if performed improperly or if significant margins of error exist in a given procedure. Thus, to test the reliability of all the clinical examinations in this study, they were repeated 10 times (see Appendices E,F,G) and used only when found to be within the acceptable tolerance limits for anthropometric measurements as recommended by various authors (Martin et al., 1986; Occhipinti et al., 198()). The clinical tests used in this study are frequently performed in the evaluation of certain musculoskeletal disorders (Brooks et al., 1975; Smith et al., 1988; Kisner and Colby, 1985).

During this stage of the clinical examination, data were collected in the following categories:

1. **Demographic data:** Including age, mass, stature and family history of scoliosis, as well as medical surgical and developmental history. Handedness was established by asking the child to write his or her name.
  
2. **Anthropometric measurements:** the anthropometric parameters chosen were those that have a functional role in the general aims of the clinical examination, and were aimed at observing any lateral asymmetries along the body. The following measurements were made, all within tolerance limits of 5 mm:
  - A. **Height of acromia:** The vertical distance from each acromion to the floor.
  - B. **Scapula - spine distance:** measured horizontally from the inferior angle of each scapula to the nearest vertebral thoracic spinous process (Figure 21).
  - C. **Biacromial diameter:** The maximum distance between right and left acromia, measured from behind with the subject standing. The pointer was brought down onto each acromion from above.
  - D. **Height of Anterior Superior Iliac Spines (ASIS):** The vertical distance from each ASIS to the floor.
  - E. **Lower limb length:** measured from the ASIS to the medial malleolus, with the subject

lying supine.

- F. Bi-ASIS diameter: the maximal diameter between right and left ASIS. The subject stands erect with the heels together. The measurement is taken from the front with the arms of the anthropometer applied firmly to the bony landmarks.

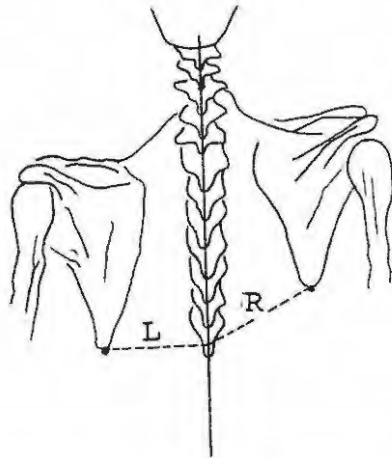

**Figure 21** : Scapula-to-Spine distance.

**Equipment for anthropometric measurements:**

A sliding pointer was used for measurements A and D alone. This pointer moved vertically to measure distances to the floor while the subjects were instructed to stand in a comfortable erect position. A flexible tape was used for measurement E alone, and a calliper was used for measurements B, F and C.

**3. Functional measurements:**

Each motion was performed once only.

- A. Trunk flexion (thoracolumbar spine): The distance between the spinous processes of  $C_7$  and  $S_1$  in the

start position with the subject standing, and at the limit of motion with the subject flexing the trunk forward (Figure 22).

- B. Lateral bending test: measurement of distance between C<sub>7</sub> and seating plane with the subject sitting erect and at limit of motion with the subject bending laterally to the right and left sides (Figures 18; 19). The Pelvis was stabilized to the plane of the seat.
- C. Spinal rotation: rotation angle of the spine (cervical spine excluded) with the subject sitting and at limit of motion with the subject rotating the spine to the right and left sides. The Pelvis was stabilized and a pointer was connected to the sternum to measure angular movement.
- D. Shoulder flexibility: Both shoulder joint and shoulder girdle flexibility were examined.

Test position: the right elbow was raised and the right hand reached down between the shoulders with the subject sitting erect. The left hand was placed in the small of the back with the palm facing away from the back (Figure 23). The distance between the hands if not overlapped or the amount of fingers overlap was measured.

- E. Hamstring flexibility: measurement of the angle of straight leg raising in a supine position, with the lower extremities extended.

**Equipment for functional measurements:**

A flexible tape was used for measurements A and D, which are recorded in centimetres. A sliding pointer was used for measurement B and a goniometer was used for measurements C and E.

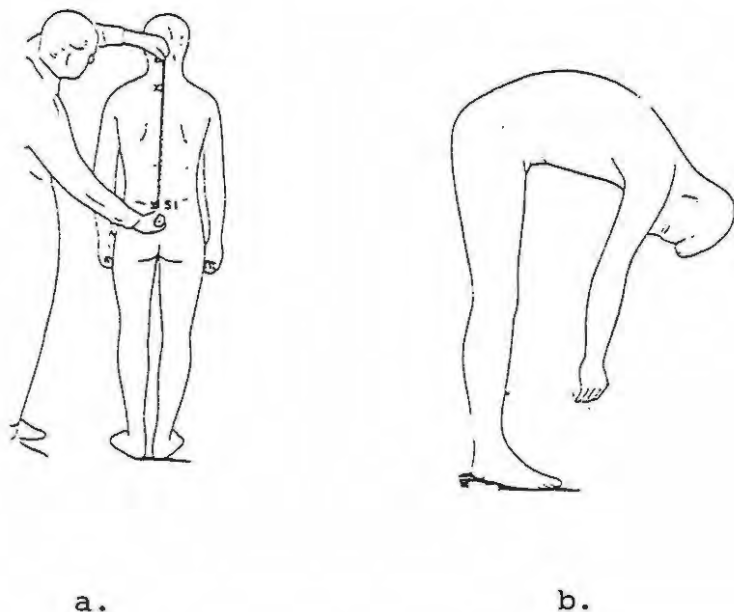

**Figure 22 :** Trunk flexion measurement (C<sub>7</sub>-S<sub>1</sub>). (a) Start position. (b) End position.  
(Hay and Reid, 1978)



**Figure 23 :** Shoulder flexibility measurement.  
(Hay and Reid, 1978)

The error for each functional measurement was as follows:

- A. Trunk flexion:  $\pm 5\text{mm}$
- B. Lateral bending:  $\pm 5\text{mm}$
- C. Spinal rotation:  $\pm 4^\circ$
- D. Shoulder flexibility:  $\pm 5\text{mm}$
- E. Hamstring flexibility:  $\pm 2^\circ$

4. **Scapular asymmetry:**

The angle of frontal plane scapular asymmetry was determined using the linear distance between the acromion (h) and the vertical difference in acromial height measured from the floor (o) as depicted in Figure 24. Thus the angular asymmetry is given by:

$$\Theta = \text{Arc Sin } o/h$$

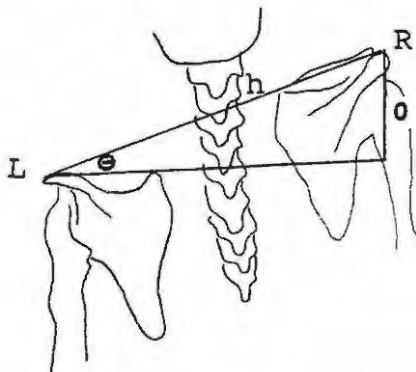
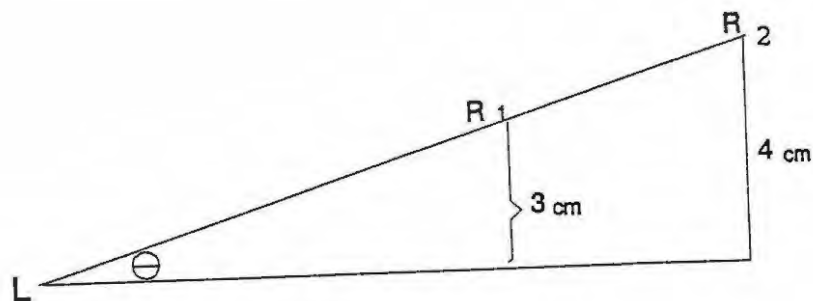

Figure 24 : Angular asymmetry of scapulae.

The scope of the available techniques for measuring lateral symmetries can be broken into three main areas. First, there are many methods for quantifying the shape of a patient. Second, measurements of change of shape quantify motion and flexibility or over a period of time detect change or progression of the truncal deformity. Third, there are

measurements of the forces generated within the musculoskeletal system and of the external forces applied to the body. Several researchers have reported that the development of a curvature is most likely during periods of rapid growth (Taylor, 1983; Loncar *et al.*, 1991). Since the development of scoliosis is so intimately related to the development and growth of the skeleton, physical anthropometry can be an important measurement tool. However, quantifying change of shape, over time, especially as it relates to scoliotic progression or response to treatment, is also an important clinical problem. The precision of measurement techniques is crucial to accurate detection of change, especially in the case of back-surface measurement whose magnitude is small compared with the magnitude of the underlying skeletal deformity. As previously noted, one of the major factors limiting the understanding of the relationship between therapeutic physical activity and scoliosis is the lack of easily administered valid and reliable measures, which will obviate false conclusions.



**Figure 25 :** Asymmetry of acromial height.

As Figure 25 shows, a taller subject (with presumably broader chest), appears to exhibit a greater asymmetry in terms of disparate heights of left (L) and right (R) acromia, while in fact this may be an artifact of body size. Even if stature is identical, an individual with larger bi-acromial axis may exhibit an apparent (but not real) increase in asymmetry. Thus in the present study asymmetry was viewed as an angular deviation which is independent of size, and  $\Theta$  in Figure 25 is identical, despite a considerable apparent difference in left and right acromial height. On the assumption that a subject undergoing an adolescent growth spurt could conceivably grow in stature and or bi-acromial diameter without in fact changing the relative level of asymmetry, this would convey a spurious impression that the asymmetry had increased when in fact it might even have diminished (Figure 26).

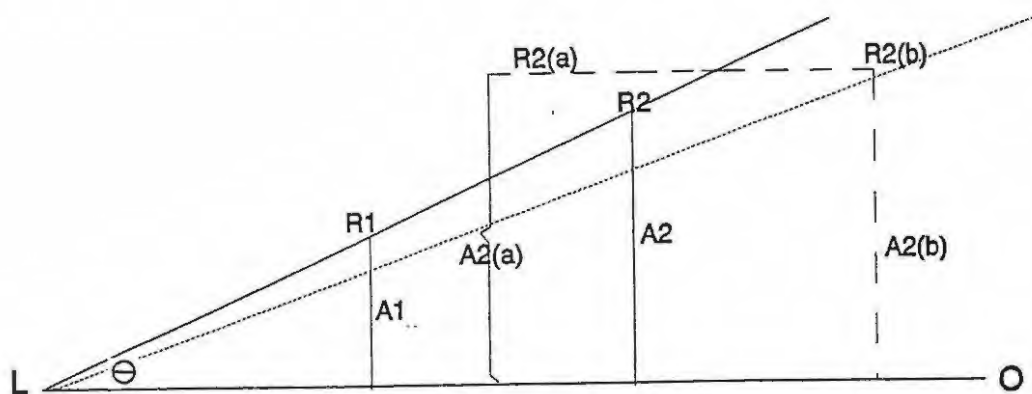

**Figure 26** : Angle of asymmetry.

- L-R<sub>1</sub> : Original measure.
- L-R<sub>2</sub> : Later measure.  $A_2 > A_1$  but  $\Theta$  is constant.
- L-R<sub>2(a)</sub> : Later measure.  $A_2(a) > A_1$  and  $\Theta$  is increased.
- L-R<sub>2(b)</sub> : Later measure.  $A_2(b) > A_1$  but  $\Theta$  is decreased.

Thus the angle  $\Theta$  expresses acromial height asymmetry better, as of size-independent measure, and therapeutic interventions are then aimed at reducing  $\Theta$  to zero, while growth changes are factored-out. This will also enable data from different age groups to be pooled for statistical analysis.

#### 5. Measurements on the Radiographs

Following the clinical tests, subjects suspected of scoliosis were examined again in order to decide whether to take radiographs and to define, if necessary, treatment. Positive findings at this stage would lead to Radiographic examination. The research protocol was approved by the appropriate sub-committee on ethical standards which required, inter-alia, the direct personal involvement of an orthopaedic surgeon during the x-ray phase, to ensure that only children deemed on medical grounds to require x-ray screening would be subjected to this intervention.

One anteroposterior roentgenogram was taken of each subject in a standing position, using a large 36 x 43 cm cassette and directing the central ray horizontally to the mid-point of the film. These radiographs were analyzed using the following measurements:

1. All spinal curvatures were measured in degrees as described by Cobb (1960).

2. Measurement of the general spinal deviation was developed, as follows:

a. A plumb-line parallel to a true vertical on the radiograph was drawn through the spinous process of C<sub>7</sub>. In cases of a cervical curve, this line was drawn from the first symmetrical vertebrae.

b. 5 anatomical points were then identified on each vertebral body within the curve (Figure 27), and used to find the middle point of the vertebra.

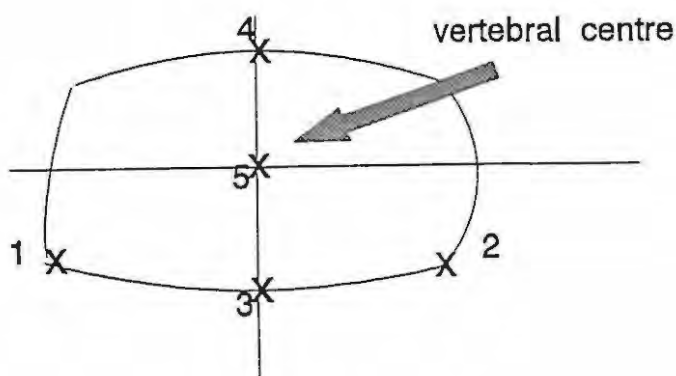
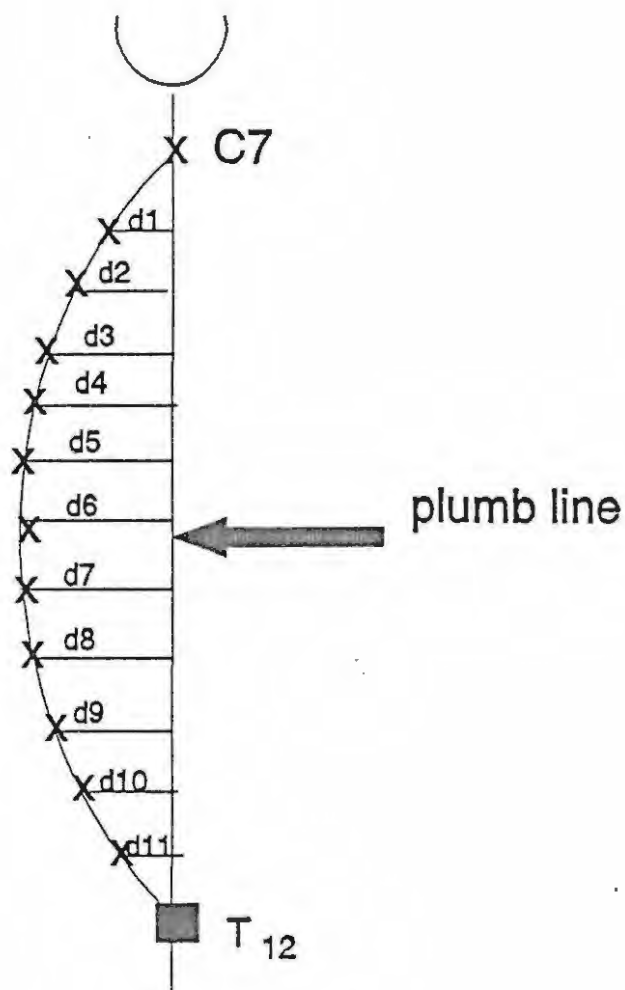

Figure 27 : Measurements of the width and height of each vertebral body, to find its centre.

c. The distance between each vertebral centre and the plumb line was measured to the nearest millimetre and the spinal deviation relative to this vertical line was then calculated using a simple ratio relationship:

$$SD = \Sigma d/H$$

Where SD is the extent of spinal deviation; d is the distance of each vertebrae from the plumb line; and H is the height of the vertebral body of the twelfth thoracic vertebra. This ratio relationship ensured standardization of the measurement if the child grew in size and/or if projected x-ray image altered from test to test.



**Figure 28 :** Measurement of spinal deviation on radiograph of a left thoracolumbar scoliosis, using C<sub>7</sub> as a reference vertebra (zero deviation).

3. The area under the curve (Figure 29) was measured, as follows:
  - a. A straight line was drawn between all the vertebral centra within the curve.
  - b. The area under the curve (ie between the plumb line and the curve) was measured in square centimetres using a compensating polar planimeter.
  - c. For standardization of the measurement, this result was divided by the area of the body of T<sub>12</sub> as measured on the same x-ray. Thus:

$$\text{SRD} = C/A$$

Where SRD is the size-relative curve amplitude encompassing spinal deviation, C is the area under the curve, and A is the area of the twelfth thoracic vertebra. This ratio relationship was used to ensure standardization of the measurement.

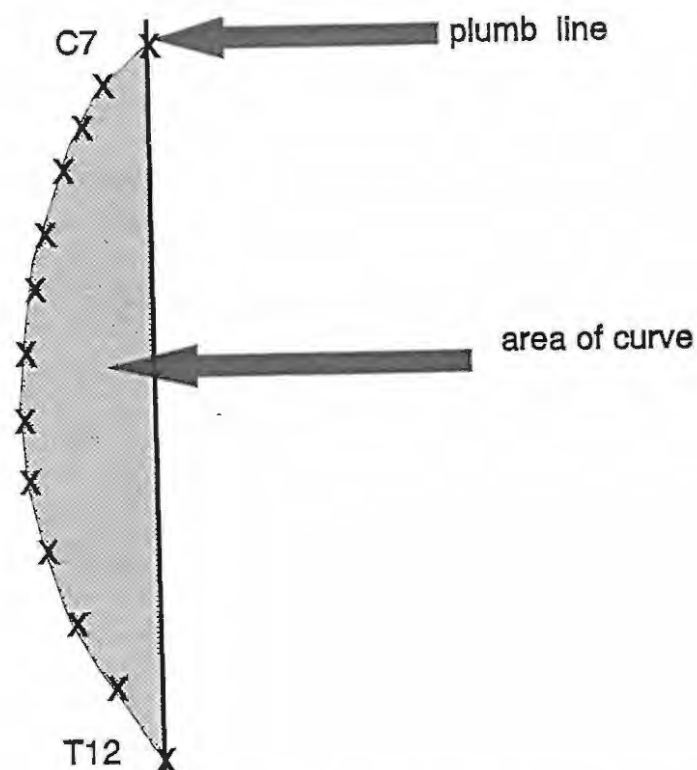
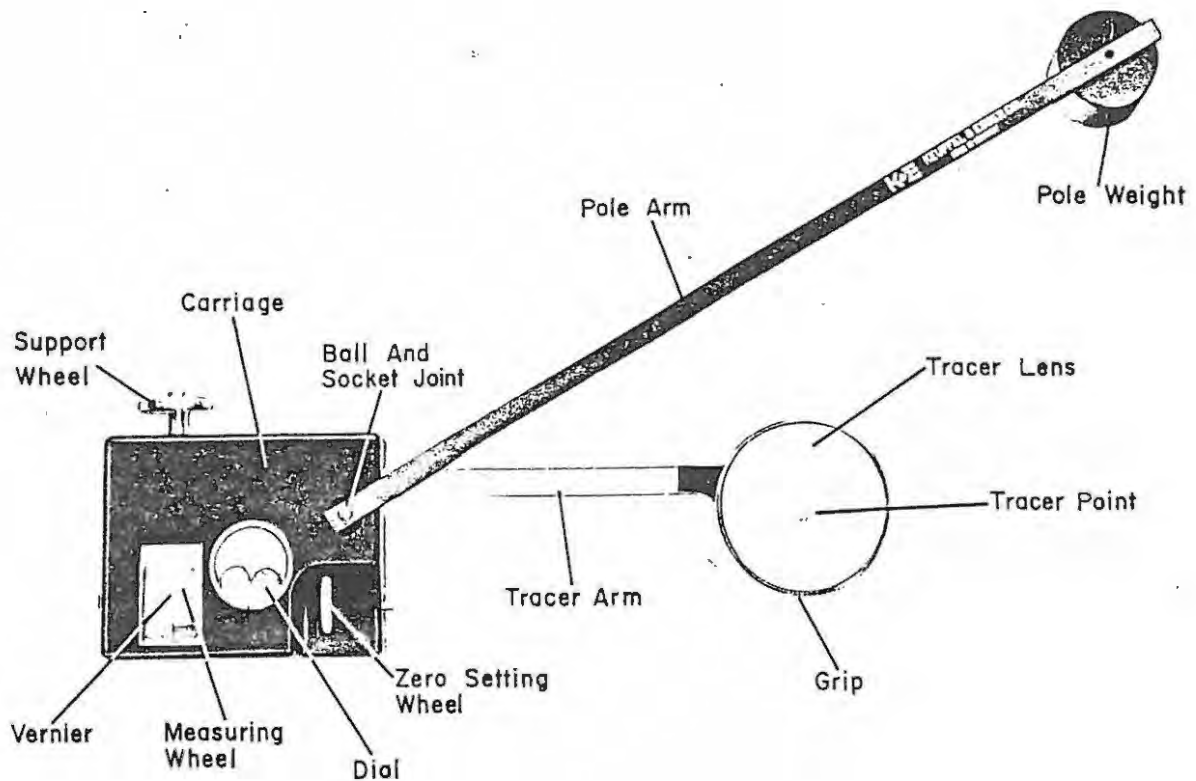

Figure 29 : Measurement of the area under the curve.



**Figure 30 :** A compensating polar planimeter used to measure the area under the curve. The tracer point was run around the periphery of the curve and the measured area was recorded in square centimetres (Keuffel and Esser, 1963).

### **Treatment condition**

Following examinations and x-rays, the subjects were requested to participate in a 60-treatment exercise therapy programme in which a graduated regime was provided to enhance each subject's muscular strength, neuromuscular coordination and joint range of motion (ROM) according to individual needs. The subjects were seen three times weekly for 20 weeks and a warm, well-lit room was utilized throughout.

### Exercise procedures and programme

The aim of the treatment was to provide therapeutic regimens differentiated by each patient's initial functional condition. The treatment was specifically adjusted to the subjects, taking account of the direction and extent of the curve(s). The programme was designed to release muscles contracture on the concave side of the spine, since soft tissue contracture in this area is one of the main forces maintaining the deformity, resisting correction and rejecting implants (Nudelman and Reis, 1990).

The lateral deviation of the spine might also reduce the ability of the intervertebral disc to distribute weight effectively and a decrease in the disc height might occur, causing abnormal weight-bearing by the facet joints and an alteration in facet joint alignment (Cailliet, 1975). Therefore, one of the general aims of treatment was to encourage awareness of the use of the spine in everyday life, and teach the application of mechanical principles of kinetic handling in activities of daily living.

The exercise system and procedures were developed by the author. The exercises were taught to the subjects during an orientation session. Before the subjects were allowed to participate in the study, they were required to perform the exercises correctly. Subjects were individually supervised during their exercises to ensure correct execution. A log was kept recording exercise dosage data in the following

categories: intensity, repetition and frequency. Adjustments of exercise intensity were made for exercise progression each month. Treatment sessions were of 1h duration each. During the first two weeks, quality of performance of the exercises was emphasized. In addition to performing exercises during the treatment sessions, the subjects were instructed to do these same exercises at home.

The exercises were of two types. The first, which consisted of ten exercises, was a standard conditioning routine to maintain the strength of the trunk muscles as well as its normal range of motion. (For exercise descriptions see Appendix I). Vigorous exercises included incidental movements which were directed at active correction of the major curve. The second type comprised six exercises involving specific movements designed to diminish the curve of the individual in question.

After 20 weeks (60 treatments) subjects were re-evaluated and the initial measurements were compared to post-programme responses. Paired t tests were used to evaluate the effectiveness of the programme in reducing bodily imbalance, improving spinal functionality and altering the Cobb angle as measured on the x-rays.

#### **Assistants**

The assistant in this study was experienced in clinical testing and familiar with the protocols and equipment being

used. Both the author and the assistant were certificated exercise therapists.

## CHAPTER 4

### RESULTS AND DISCUSSION

#### PILOT STUDY RESULTS

To ensure early treatment and prevention, school screening for scoliosis has burgeoned throughout North America and elsewhere (Brooks *et al.*, 1975; Lonstein, 1977; Rogala *et al.*, 1978; Lonstein *et al.*, 1982). The screening test in this study involved examining the child while standing and bending forward, to detect signs of asymmetric trunk topography, particularly of a "rib-hump" prominence due to spinal rotation (Kisner and Colby, 1985).

In the current study, 1052 children were screened (561 boys and 491 girls). Fifty seven subjects (5.4% of the sample) were found to have positive physical signs, 36 boys (6.41%) and 21 girls (4.27%). The average age at the time of physical examination was 10.6 years. Table II and Figures 31 and 32 show the distribution of positive physical signs as found in the screening phase. Table III presents the existence of obvious lateral asymmetries which were later found in 20 children (12 boys and 8 girls) during the clinical examinations. Thus, the estimate of the incidence rate of lateral asymmetries in this population was 1.90%.

TABLE II : Screening Programme Results

Age Group	In each cell, the number of positive physical signs is shown, over the number of children measured					
	Boys	Incidence (%)	Girls	Incidence (%)	Total	Combined Incidence (%)
8	15 / 258	5.81	9 / 196	4.59	24 / 454	5.28
9	7 / 98	7.14	4 / 113	3.53	11 / 211	5.21
10	6 / 91	6.59	5 / 72	6.94	11 / 163	6.74
11	4 / 79	5.06	3 / 71	4.22	7 / 150	4.66
12	2 / 14	14.28	0 / 22	0.00	2 / 36	5.55
13	1 / 13	7.69	0 / 11	0.00	1 / 24	4.16
14	1 / 8	12.5	0 / 6	0.00	1 / 14	7.14
Total	36 / 561	6.41	21 / 491	4.27	57 / 1052	5.41

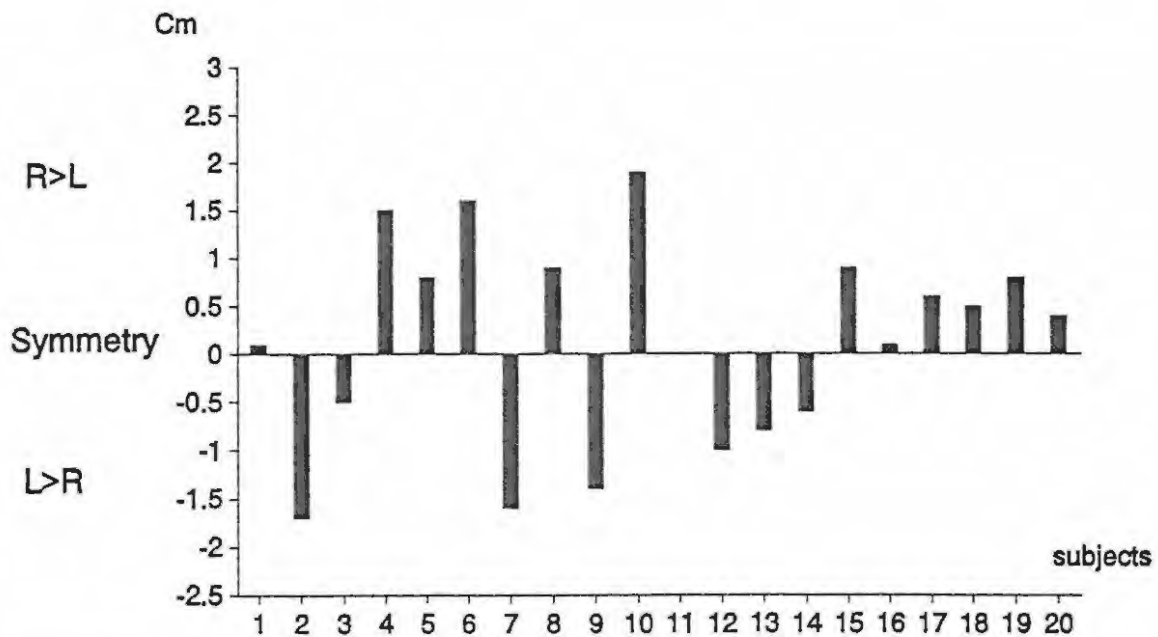

Figure 31: Direction of asymmetry in acromial height. The ratio R/L was used to indicate the direction of the acromial asymmetry. R>L designated + value (right acromion higher); R<L designated - value (right acromion lower).

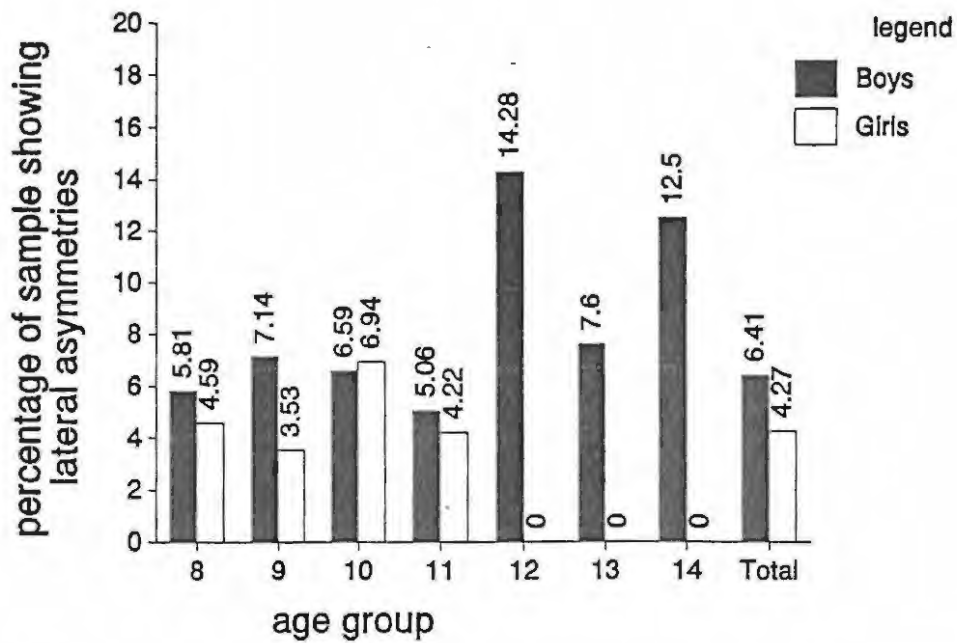

FIGURE 32 : Incidence of Lateral Asymmetries (N = 1052)

TABLE III: Clinical examination results.

Number of Children who underwent clinical examinations			Number of Children with Positive Physical signs of Lateral Asymmetries			Combined % incidence of total examined Sample (n = 1052)
Boys	Girls	Total	Boys	Girls	Total	
36	21	57	12	8	20	1.90

#### Analysis of clinical data in the pilot study

Of 57 children who underwent the clinical examination, 20 were found to have clear signs of lateral asymmetry. These, according to overall impression regarding the extent of asymmetry, were divided into two groups: one group of 10 children with "severe" lateral asymmetries and one of 10 children with "mild" asymmetries.

Since only 10 subjects could participate in the study, this analysis was done to avoid unnecessary x-ray examination of those who would not participate. To test whether this clinical assignment of subjects to "severe" and "mild" categories in fact differentiated the greater from the lesser signs, t tests ( $p < 0.05$ ) for independent groups were conducted on the data.

In order to be able to compare different asymmetries at different sites on the same scale, an asymmetry ratio (AR) was derived as follows:

$$AR = H/L - 1$$

Where: H = higher shoulder height, and L = lower shoulder height. Thus, all data were recorded as positive values. For each subject AR was calculated for the following measurements:

1. Heights of acromia, bilaterally.
2. S<sub>1</sub>-Acromion distance, bilaterally.
3. Scapula-to-spine distance, bilaterally.
4. C<sub>7</sub>-Acromion distance, bilaterally.

The results of these analyses are presented in the following two tables:

TABLE IV: Asymmetry Ratios from the clinical measurements.  
(H/L-1)

Group	Subject No	Height of Acromia	S <sub>1</sub> to Acromia Distance	Scapula to Spine Distance	C <sub>7</sub> to Acromia Distance	Summed Asymmetry
Severe Group	1	0.0009	0.0000	0.0769	0.0406	0.1184
	2	0.0186	0.0487	0.1250	0.0869	0.2792
	3	0.0039	0.1818	0.0322	0.1428	0.3607
	4	0.0146	0.0212	0.2857	0.0000	0.3215
	5	0.0071	0.0152	0.1666	0.0318	0.2207
	6	0.0165	0.0394	0.3529	0.0489	0.4577
	7	0.0166	0.0138	0.1212	0.1153	0.2669
	8	0.0090	0.0422	0.3333	0.0489	0.4334
	9	0.0126	0.0287	0.0000	0.0206	0.0619
	10	0.0194	0.0439	0.0500	0.0357	0.1490
	Σ	0.1196	0.4354	1.5440	0.5719	2.6709
	$\bar{x}$	0.0119	0.0435	0.1544	0.0571	0.2670
	SD	0.0064	0.0511	0.1276	0.0444	0.1317
Mild Group	11	0.0000	0.0183	0.3461	0.0344	0.3988
	12	0.0099	0.0285	0.0625	0.0000	0.1009
	13	0.0075	0.0000	0.0000	0.1111	0.1186
	14	0.0049	0.0508	0.0000	0.0000	0.0557
	15	0.0083	0.0102	0.1428	0.0869	0.2482
	16	0.0009	0.0340	0.1250	0.0689	0.2288
	17	0.0054	0.0198	0.2380	0.1290	0.3922
	18	0.0045	0.0000	0.0000	0.0967	0.1012
	19	0.0077	0.0333	0.0434	0.0000	0.0844
	20	0.0038	0.0219	0.0434	0.0000	0.0691
	Σ	0.0535	0.2171	1.0015	0.5273	1.7994
	$\bar{x}$	0.0053	0.0217	0.1001	0.0527	0.1799
	SD	0.0032	0.0159	0.1154	0.0517	0.1304
	t <sub>0</sub>	2.9330	1.2898	0.9975	0.2066	1.4868
t <sub>c</sub> (df18:α 0.05=2.1009)		SIG	NS	NS	NS	NS

**TABLE V: Angle of Asymmetry Resulting from Differences in Acromial Height.**

Group	Subject No	Angle of Asymmetry ( $\Theta$ )
Severe Group	1	0.1
	2	3.3
	3	0.7
	4	2.8
	5	1.4
	6	3.1
	7	3.3
	8	1.7
	9	2.7
	10	3.8
		$\bar{x}$ 2.31
		SD 1.24
Mild Group	11	0.0
	12	2.0
	13	1.5
	14	0.9
	15	1.7
	16	0.1
	17	1.0
	18	0.8
	19	1.3
	20	0.6
		$\bar{x}$ 1.0
		SD 0.64
		$t_0$ 2.8731
$t_c(df18:\alpha0.05) = 2.1009$		SIG

Table IV shows that the magnitude of the overall asymmetry was lower in the mild group. The difference in absolute magnitude in terms of mean values according to the asymmetry ratio (H/L-1) was 0.27 cm for the severe group versus 0.18 cm for the mild group and at first glance the data appear to show two different groups. However, statistical analysis

indicated that no significant difference existed. Therefore all 20 children underwent x-ray examinations.

## EXPERIMENTAL RESULTS

### Pre-treatment Roentgenographic Findings

The criteria for the existence of scoliosis in this study included the presence of obvious truncal lateral asymmetries as well as confirmation of those signs in the erect anteroposterior roentgenogram of the spine using as criterion a minimum of 5°, determined by Cobb's technique.

Thus 20 children with positive findings of lateral asymmetries went through x-rays. The results of these x-ray films are presented in Tables VI and VII.

**TABLE VI:** Distribution of Pre-Treatment Roentgenographic Signs.

Number of x-rays taken	Incidence of scoliosis of 5° or more	Incidence of scoliosis under 5°	Number of subjects with no scoliosis	Incidence of scoliosis in the screened population (n=1052)
20	12	6	2	1.14 %

TABLE VII: Distribution of Pre-Treatment Roentgenographic Signs among subjects with Scoliosis of 5° or more.

No	Sex	Age	Stature (cm)	Mass (Kg)	Type of Curve	Side of Curve	Cobb Angle (deg)	Area: SRD=C/A)	Deviation (SD=Ed/h)
1	M	12	152.1	34.6	Single	Left	27	47.8	8.2
2	M	9	145.0	30.0	Single	Left	7	27.0	6.5
3	M	13	157.6	37.6	Single	Left	12	66.0	12.3
4	M	10.5	134.7	26.6	Single	Left	6	42.4	7.0
5	M	9.5	142.1	29.0	Single	Left	11	17.5	4.4
6	M	12	145.7	37.8	Single	Left	7.5	12.2	2.5
7	M	8.5	126.0	26.3	Single	Left	9.5	13.6	2.6
8	F	10	141.2	26.1	Single	Left	8	41.0	9.7
9	F	9.5	137.5	30.9	Single	Right	7	10.5	2.8
10	F	6.5	121.1	23.2	Single	Right	9	31.0	7.8
11	M	15	172.1	54.2	Single	Right	15	28.2	3.2
12	M	9	129.9	25.7	Double	left lumbar right thoracic	9 5	11.9	3.1
$\bar{x}$	-	-	142.08	31.86	-	-	10.66	29.09	5.84
SD	-	-	13.50	8.13	-	-	5.47	16.68	3.09

**Pre-treatment clinical findings:**

Only 10 subjects with scoliosis of 5° or more went through the next stage of clinical examination. Subjects 2 and 5 (see Table VII) were excluded from the experiment due to logistic difficulties related to attendance in the programme.

**Anthropometric measurements:**

The results of the anthropometric measurements are presented in Tables VIII and IX.

**TABLE VIII: Programme effects on selected asymmetry measures (H/L -1)**

Condition	Subject No	ACROMIAL HEIGHT	S <sub>1</sub> -ACROMIA DISTANCE	Scapula to Spine Distance	C <sub>7</sub> ACROMIA DISTANCE	SUMMED ASYMMETRY
PRE-TREATMENT	1	0.0170	0.0975	0.1333	0.0179	0.2657
	2	0.0039	0.0082	0.1084	0.0643	0.1848
	3	0.0126	0.0243	0.0547	0.0000	0.0916
	4	0.0067	0.0336	0.4074	0.0551	0.5028
	5	0.0099	0.0285	0.0625	0.0000	0.1009
	6	0.0104	0.0429	0.7142	0.1150	0.8825
	7	0.0009	0.0393	0.2321	0.0429	0.3152
	8	0.0070	0.0263	0.1315	0.0645	0.2293
	9	0.0171	0.0601	0.6500	0.0714	0.7986
	10	0.0097	0.0930	0.0000	0.0000	0.1027
	Σ	0.0952	0.4537	2.4941	0.4311	3.4741
	$\bar{x}$	0.0095	0.0453	0.2494	0.0431	0.3474
	SD	0.0052	0.0295	0.2548	0.0383	0.2883
POST-TREATMENT	1	0.0046	0.0111	0.0000	0.0000	0.0157
	2	0.0000	0.0000	0.0377	0.0259	0.0636
	3	0.0026	0.0087	0.0294	0.0000	0.0407
	4	0.0000	0.0117	0.1290	0.0222	0.1629
	5	0.0000	0.0000	0.0000	0.0000	0.0000
	6	0.0000	0.0147	0.1000	0.0400	0.1547
	7	0.0000	0.0000	0.1153	0.0140	0.1293
	8	0.0000	0.0105	0.0000	0.0384	0.0489
	9	0.0000	0.0044	0.0000	0.0333	0.0377
	10	0.0000	0.0000	0.0000	0.0000	0.0000
	Σ	0.0072	0.0611	0.4114	0.1738	0.6535
	$\bar{x}$	0.0007	0.0061	0.0411	0.0173	0.0653
	SD	0.0016	0.0059	0.053	0.0167	0.0617
	t <sub>o</sub>	6.1893	4.1655	2.7894	3.505	3.4654
t <sub>c</sub> (df9α0.05)= 2.2628		SIG	SIG	SIG	SIG	SIG

**TABLE IX :** Programme-Effects on Acromial Angle Asymmetry.

Condition	Subject No	Angle of Asymmetry (°)
PRE-TREATMENT	1	4.3
	2	1.0
	3	3.1
	4	1.9
	5	2.0
	6	2.8
	7	0.1
	8	2.4
	9	4.2
	10	2.1
		$\bar{x}$ 2.39
		SD 1.2
POST-TREATMENT	1	1.2
	2	0.0
	3	0.6
	4	0.0
	5	0.0
	6	0.0
	7	0.0
	8	0.0
	9	0.0
	10	0.0
		$\bar{x}$ 0.18
		SD 0.4167
		$t_0$ 6.4635
$t_c$ df9; $\alpha$ 0.05 = 2,2622		SIG

A high degree of reliability was evidenced for repeated anthropometric measurements taken by the same examiner (see Appendix F). These findings are in agreement with results obtained by other investigators (Licht,1965; Vercautern et al.,1982).

Table VIII shows that the exercise programme had a positive effect on all the asymmetries which were observed in the anthropometric measurements. The general asymmetry scores ( $\Sigma H/L-1$ ) were significantly decreased ( $p < 0.05$ ) by the treatment programme.

#### **Angle of acromial asymmetry:**

The angle of acromial asymmetry appears to serve not only as a good indicator of the need for treatment, but as a quantitative measurement of realignment. A comparison between pre- and post-treatment results shows a significant improvement after the programme (Table IX).

#### **Functional measurements**

Functional tests were used in this study as a means of the determining functional limitations of the scoliotic spines and extent of truncal asymmetries.

The comparison between functional measurements of pre- and post-treatment examinations are presented in Table X.

TABLE X: Programme-Effects on Functional Measurements.

Condition	Subject No	Difference in Lateral Bending ROM (Cm)	Differences in Right/Left Shoulder Flexibility (Cm)	Differences in Truncal Rotation to Right and Left (in degrees)
PRE-TREATMENT	1	0.7	3.0	4.0
	2	1.0	3.0	9.0
	3	5.7	9.0	5.0
	4	2.2	6.0	2.0
	5	1.0	6.0	4.0
	6	2.1	6.0	6.0
	7	2.4	0.0	4.0
	8	4.0	4.0	1.0
	9	2.1	7.0	0.0
	10	2.0	0.6	2.0
		$\Sigma$ 23.2	40.2	37.0
		$\bar{x}$ 2.32	4.02	3.7
		SD 1.512	2.931	2.6268
POST-TREATMENT	1	0.3	1.0	1.0
	2	0.1	0.0	2.0
	3	0.5	5.0	3.0
	4	0.3	2.0	0.0
	5	0.4	4.0	0.0
	6	0.1	0.0	1.0
	7	0.7	0.0	2.0
	8	1.0	2.0	2.0
	9	0.4	5.0	0.0
	10	0.0	0.5	0.0
		$\Sigma$ 3.8	19.5	11.0
		$\bar{x}$ 0.38	1.95	1.10
		SD 0.3011	2.0337	1.1005
		$t_0$ 4.4475	4.8024	3.5455
$t_c$ df9; $\alpha$ 0,05) = 2,2622		SIG	SIG	SIG

As has been noted, even small imbalances in lateral bending moments must be continually resisted by lateral tilts

of the spinal motion segments (Haderspeck and Schultz, 1981). Soft tissue growth and remodelling processes may eventually translate these small lateral tilts into the large structural lateral deformities seen in the advanced stages of scoliosis. Therefore, selecting a treatment programme that will hold or reduce the deformity of the lateral curve until growth stops, is important.

Many investigators agree that scoliosis rarely occurs in children who have bilaterally symmetrical trunk muscles (Haderspeck and Schultz, 1981; Noone et al., 1991; Schultz, 1984; Koreska et al., 1985; Ford et al., 1984; Basmajian, 1978; Alter, 1988; Crisco and Panjabi, 1991). The results of the functional measurements concur with other studies of lateral asymmetries, which found that there is a relation between scoliosis and functional imbalances (Nudelman and Reis, 1990; Kisner and Colby, 1985; Tompson, 1989). The majority of the subjects in this study presented with tightness in postural muscles, predominantly those maintaining the locomotor posture, to correlate with the concept that these muscles adaptively shorten and become tight (Janda, 1983).

The pattern of tight scapular elevators and shoulder girdle protractors with inhibited scapular retractors, which was observed in the functional examinations, confirmed the imbalance trend which Janda (1983) attributes to cervicothoracic and craniovertebral joint disorders.

Biomechanical analysis of the shoulder emphasizes the synchronized movement of four joints: gleno-humeral, scapulothoracic, sternoclavicular and acromioclavicular, (Hay and Reid, 1978). A stiff shoulder has limited capsular flexibility and altered muscle function. Therefore, in order to re-establish harmonious movement within the shoulder complex, it was necessary to rehabilitate the connective tissue by restoring its extensibility and a more normal muscle balance.

In addition to direct measurement of the shoulder joint, indirect methods are often used to quantify range of motion of a joint or a series of joints. The test which was used in this study to evaluate the flexibility of the shoulders provided general information and was used as a test-retest indicator of flexibility improvement.

As can be seen in Table X, the treatment apparently exerted a significant influence on all the observed functional asymmetries, over the 20 week period of the programme ( $P < 0.05$ ).

#### **Results of measurements on the x-ray films:**

In Roentgenographic examinations, magnification of the image depends on the tube position. A magnification factor was taken into account to standardize this.

Because all of the geometric information was compressed onto a single film plane, the magnification varies with the position of the part of the skeleton being measured, since it is also dependent on the distance from the film plane. This may produce small differences on the radiograph and therefore all the measurements on the x-rays in this study were standardized (using T<sub>12</sub> as a reference vertebra) by the method described earlier, before the data on the spinal deformity could be obtained with confidence.

#### Cobb Angles:

The results of pre- and post-treatment curves, as measured on the X-rays, show significant reduction in Cobb angles and are presented in Figure 33 and Table XI.



Figure 33: Roentgenographic Results of pre- versus post-treatment curves (Cobb Angles).

**TABLE XI: Roentgenographic Results of Pre-Post Treatment Curves (Cobb angles).**

No.	PRE-TREATMENT	POST-TREATMENT	% REDUCTION
1	27.0	9.5	64.8
2	12.0	8.0	33.3
3	6.0	6.0	NIL
4	7.5	3.0	60.0
5	9.5	5.0	47.3
6	8.0	4.0	50.0
7	7.0	4.0	42.8
8	9.0	5.0	44.4
9	15.0	4.0	73.3
10	9.0	2.0	77.7
	$\bar{x}$ 11.0	$\bar{x}$ 5.05	54.1
	SD 6.2	SD 2.3	SIG
	$t_0$ 3.808		

$t_c (df9; \alpha 0.05) = 2.2622$
-----------------------------------

**The area under the curve:**

Figures 34, 35 and Table XII represent comparisons, (SRD=C/A), between pre- and post-treatment scoliotic curves. (See Chapter 3, Figure 29).

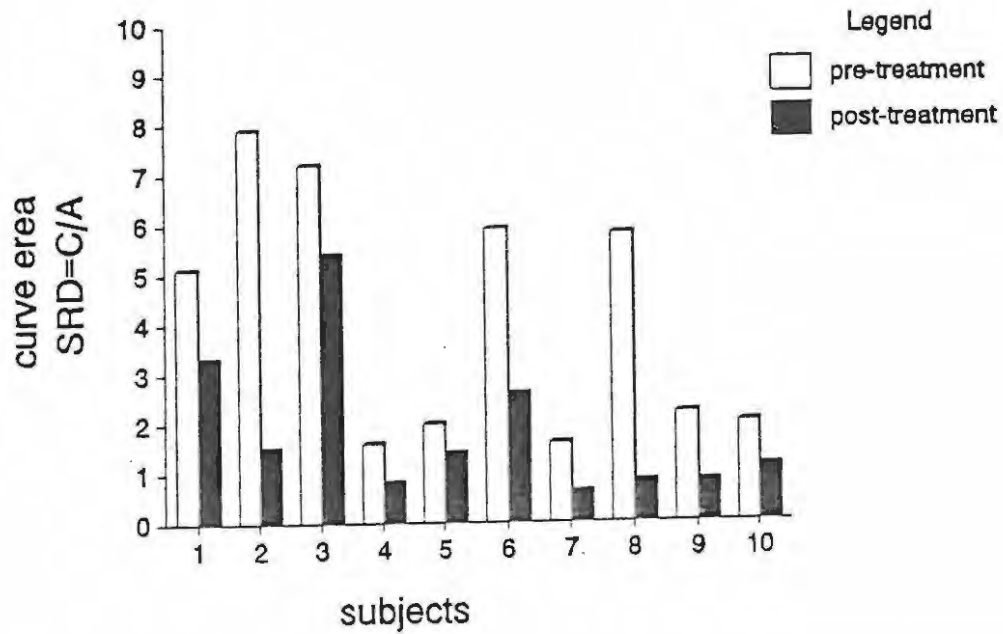

Figure 34: Pre-Post Treatment Results of the Area Under the Curve (SRD=C/A).

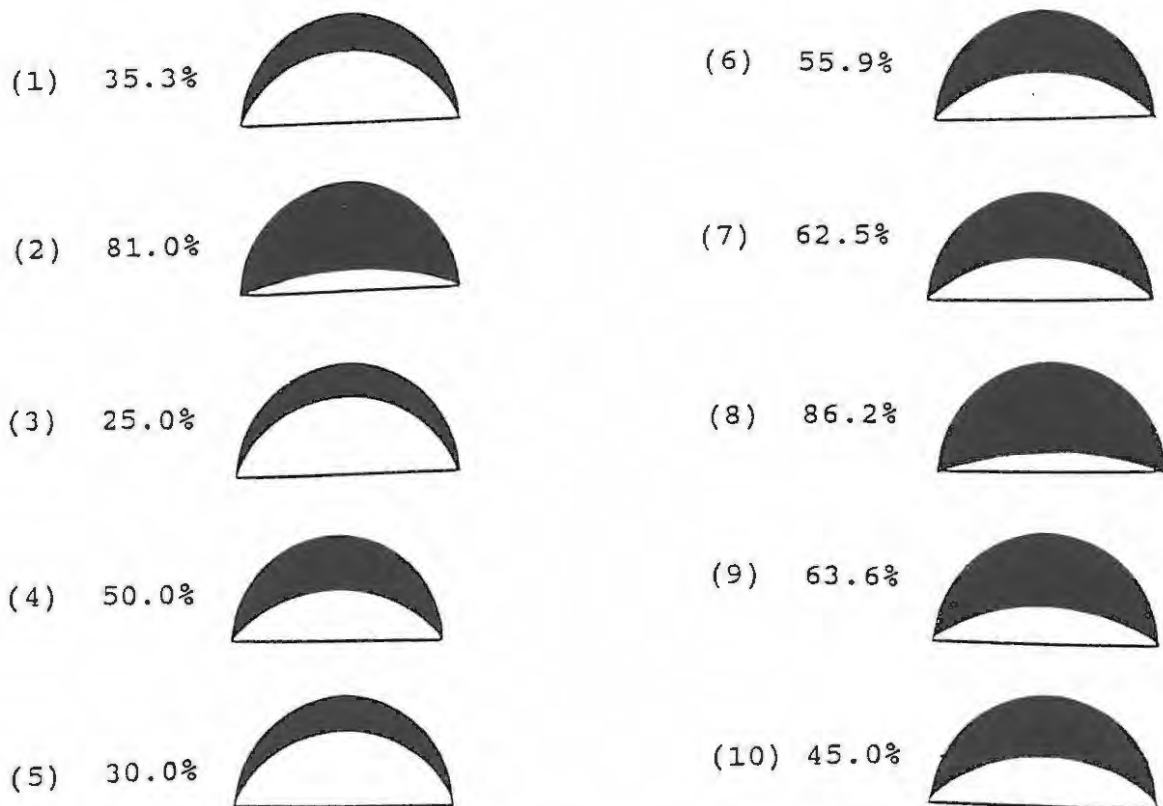

Figure 35: Percentage Reduction in Scoliotic Curves After Treatment. The shaded areas represent the percent of area reduction. Numbered curves identify the subjects.

**TABLE XII:** The area under the curve (SRD=C/A).

Subject	PRE-TREATMENT	POST-TREATMENT	% Reduction
1	5.1	3.3	35.3
2	7.9	1.5	81.0
3	7.2	5.4	25.0
4	1.6	0.8	50.0
5	2.0	1.4	30.0
6	5.9	2.6	55.9
7	1.6	0.6	62.5
8	5.8	0.8	86.2
9	2.2	0.8	63.6
10	2.0	1.1	45.0
	$\bar{x}$ 4.13	$\bar{x}$ 1.83	$\bar{x}$ 55.7
	SD2.4967	SD1.5283	-
	$t_0$ 3.6777		
$t_c = 2.2622$			SIG

**Spinal Deviation Scores ( $\Sigma d/h$ ):**

As has been presented in Chapter 3 (Figure 28), this measurement examined the extent of spinal deviation as observed on the X-rays. Figure 36 presents the comparison of

the spinal deviation scores ( $\Sigma d/h$ ) between pre- and post-treatment curves, Where SD is the extent of spinal deviation; d is the distance of each vertebrae from the plumb line; and h is the height of the vertebral body of the twelfth thoracic vertebra.

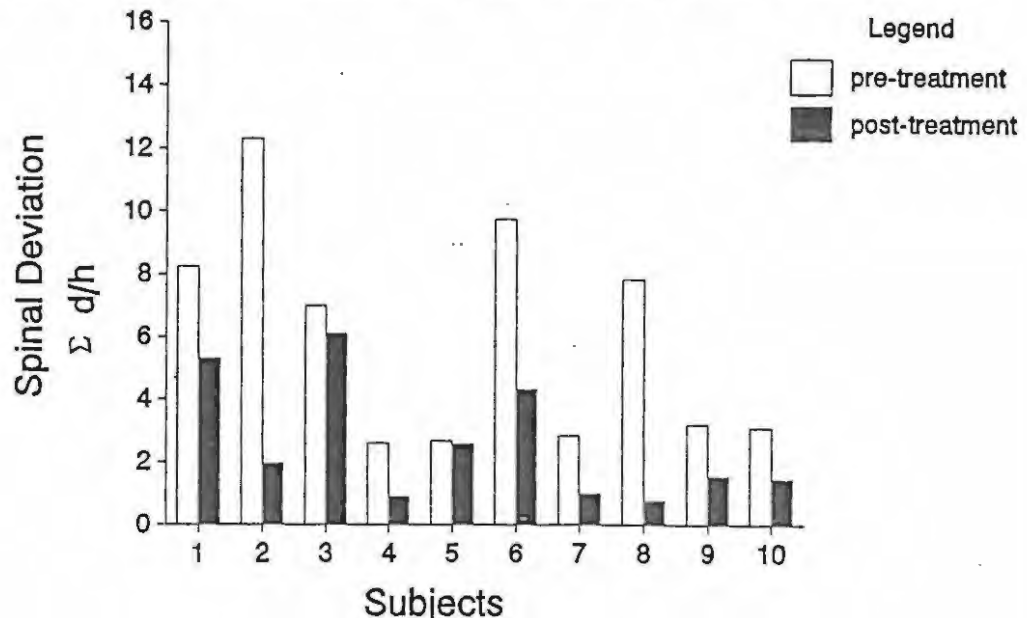
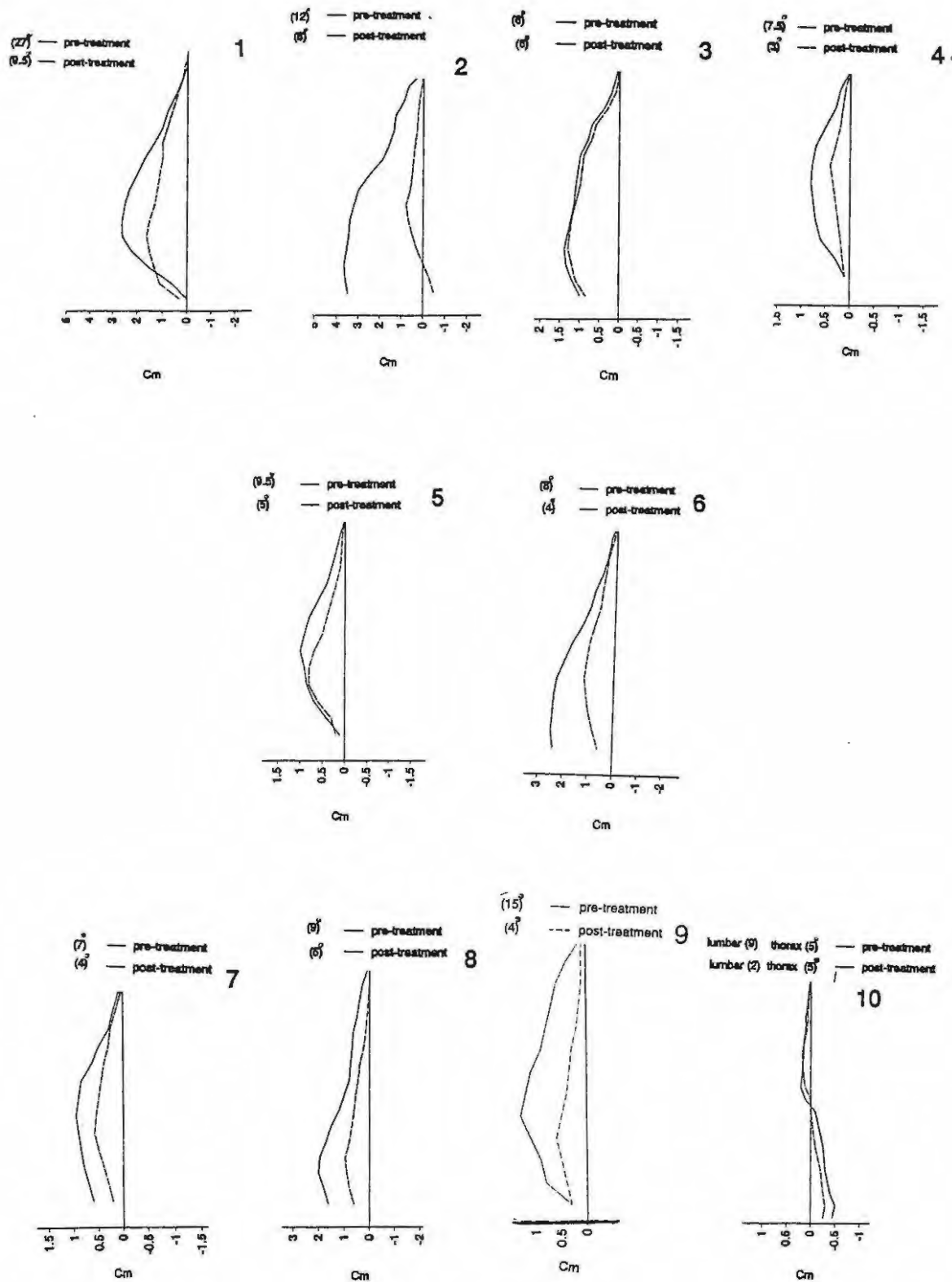
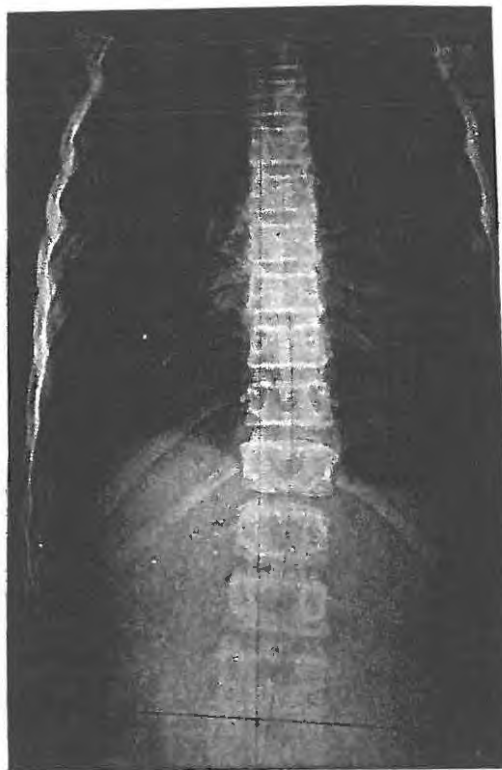

Figure 36: Spinal deviation scores ( $\Sigma d/h$ ).

From the data presented in Tables XI-XII and Figures 33-36 it would seem that the area under the curve as well as the general spinal deviation scores were significantly lower in the post-treatment measurements. The significant positive changes in these measurements, and in the Cobb angles, give some indication of the success of the training programme. The results seem to confirm the potential value of an intensive and rigorous therapeutic exercise programme in the treatment of scoliosis, and argue against the opinions postulated by Kisner and Colby (1985) and others (Keim, 1982; Roaf, 1956), who consider exercises beneficial only when performed by patients wearing trunk orthoses.



**Figure 37:** Graphic presentation of scoliotic curves. Views of spine shape as reconstructed from Radiographs. The coordinates of each vertebral centrum were plotted and vectors were drawn connecting one centrum with the next. The views are of the spines of all 10 subjects (seen in the anteroposterior view).



Subject 1: Before treatment - 27° After treatment 9.5°

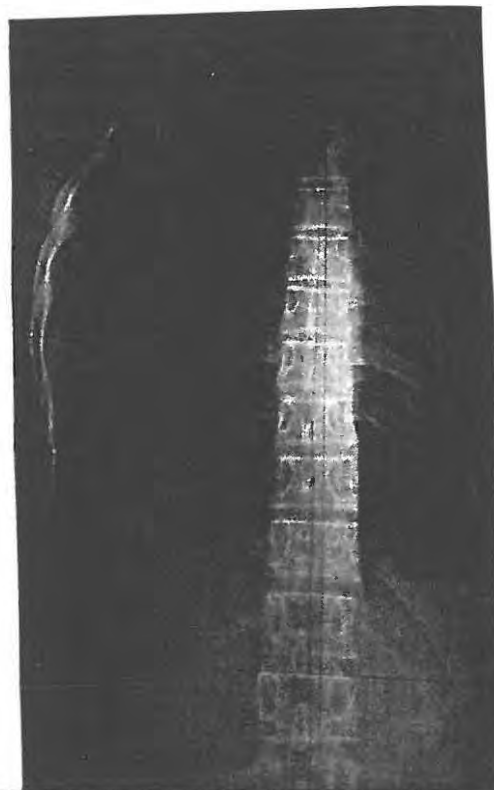
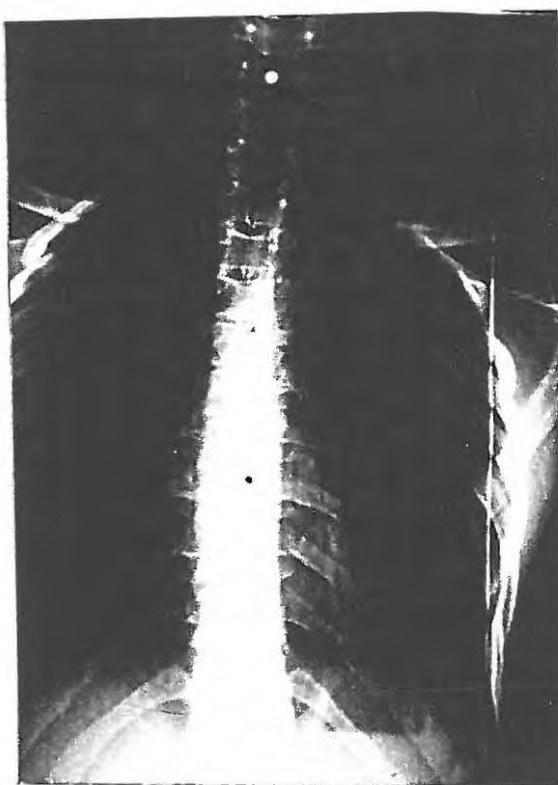

Subject 9: Before treatment - 15° After treatment - 4°

Figure 38: x-ray films of scoliotic spines before and after treatment.

### **The incidence of scoliosis:**

The presence of scoliosis among preadolescent and adolescent children may be indicative of motor development patterns having a direct relationship on the skeletal growth of the vertebrae. Research by Risser and Ferguson (1936) has shown that the scoliotic spine grows slowly from 7 to 10 years of age, and three to five degrees of curvature may develop each year during that period. The pre-adolescent age of 10 to 15 years is a period of rapid spinal growth, and curvature increases may develop as quickly as one degree per month. This would be considered a primary age for obvious scoliotic developments among children. Additional evidence of this age group being a primary population for alteration in vertebral growth has been provided by Loncar *et al.*, 1991; Dickson and Sevitt, 1982; Kane and Moe, 1970; Avikainen and Vaherto, 1983 and Brooks *et al.*, 1975. Thus, this study dealt with children in this age group.

The prevalence of demonstrable scoliosis reported in this study was 1.14 per cent (Table VI). The prevalence reported in the literature ranges from 0.4 to 14.0 per cent due to different definitions of what is regarded as scoliosis (Brooks *et al.*, 1975; Lonstein *et al.*, 1982). Some authors reported all curves that were more than 5 degrees, while others reported only those of more than 20 degrees. In the current study the diagnosis was based on the finding of a curve of 5 degrees or more, accompanied by functional and anthropometrical asymmetries.

The incidence of trunk asymmetry, as found in this study was relatively low. Table II shows the distribution of positive physical sings as found in the screening phase. Table III presents the existence of obvious lateral asymmetries which were later found in 20 children during the clinical examinations. Thus the estimate of the incidence of lateral asymmetries in this population was 1.90 per cent (before confirmation on x-rays). This is in contrast with the results of Vercautern *et al.* (1982), who reported that in the total of the examined population, clinical evidence of obvious truncal asymmetries were found in 50 per cent of the children.

#### **Measurement Procedures:**

The measurement techniques used in this study have been applied to studying the effects of treatment, as well as to improving our description of the scoliosis deformity and our understanding of its etiology.

Regarding the measurements used, although some of the traditional methods of static anthropometry using the tools of classic morphological osteology have been employed, a number of new techniques have been developed, and were used to obtain various functional measures. In consideration of the complexity of the scoliosis deformity, the author has found it necessary to quantify spinal alignment. A quantitative measurement has therefore been developed to assess the spinal deformity, as well as the resultant

alteration in alignment that is observable following a comprehensive therapeutic programme. It was concluded that there are considerable differences in lateral asymmetries between children of various stature. Therefore, the study indicates that emphasis should be placed on using measurements which are factored for size. These descriptions are useful in medical and therapeutic treatment where there is a need to identify the pathology or disability for purposes of correction.

The test sequence presented facilitated observation in an ordered way to avoid unnecessary changes in starting positions. This further encouraged efficiency during the tests and was a practical method of evaluating the musculoskeletal system in children. To ensure valid conclusions from the data, the reliability of all the measurements was determined.

The measurements used yielded acceptable test-retest reliability, and can improve the therapist's ability to decide the effectiveness of treatments. In this way modifications of the treatment plan can be initiated at an earlier phase of therapy. The author believes that the methods which were developed in the study are rigorous and would appear to reflect the magnitude of the scoliotic curve. Thus, clinicians should consider using the methods described when evaluating patients with suspected spinal problems.

The data recording forms (Appendices C,D) accommodated all the main findings from the assessments, providing quick inspection of important details when discussing the evaluation with each individual's parents.

**Results of Exercise programme and treatment procedures:**

Studies of the effect of exercise on scoliosis are lacking in the English-language literature. Exercise alone is not currently used in managing scoliosis because clinical experience has historically demonstrated progression of curves despite vigorous exercise regimens. Rather, exercise is thought to be beneficial when performed by patients wearing trunk orthoses such as the Milwaukee or Boston braces. A pilot study by Miyasaki (1980) supported the beneficial effect of one exercise when performed in the Milwaukee brace. Studies by Brooks *et al.* (1975) and Blount and Bolinke (1967) have also placed emphasis on physical therapy in the nonoperative treatment of scoliosis in a population of braced patients only.

As previously noted, much of the clinical literature suggests that scoliosis and imbalances in muscle function are related. (Nudelman and Reis, 1990; Avikainen and Vaherto, 1983; Stone *et al.*, 1979; Porttillo *et al.*, 1982; Gustavsen, 1985; Licht, 1965; Miyasaki, 1980; Steindler, 1964). Apparently this concept is based on their understanding of the anatomy of the spinal muscles and of the effect which they hypothesise these muscles have on scoliosis.

However, knowledge about the response of scoliosis to exercise alone has been gained from experience with moderate to severe curves, that is, those of approximately 20 degrees or greater. With the advent of school screening programmes, smaller curves (those less than 20 degrees) are being detected, thus affording the opportunity to investigate the effect of exercise on the small, unbraced curve. The present study was conducted to explore further the use of the therapeutic exercise programme as a tool to improve the condition of the unbraced scoliotic spine. Treatment of scoliosis by exercise therapy remains controversial, with most of the investigators reporting poor results and questioning its effectiveness (Cobb,1958; Keim,1982; Roaf,1956; Tarr,1948; Kisner and Colby,1985; Stone et al.,1979). Most of these authors contend that exercise of any kind is not beneficial in inhibiting scoliotic development.

A number of papers (Crisco and Panjabi,1991; Ford et al.,1984) have reported biochemical, histological, and ultrastructural differences in trunk muscle tissues between patients with idiopathic scoliosis and control patients. These reports might suggest that since such differences exist, no change in the curves can be achieved through any exercise programme. However, those differences appeared in tissues biopsied during surgery to correct scoliosis, so that the patients from whom they were taken in all probability had more severe curves and a longer

history of the condition than the subjects in the present study.

In 1941 the American Orthopaedic Association's Research Committee came to the conclusion, after a study of 425 cases of end-result idiopathic scoliosis, that exercise should be avoided. This study found that approximately 60 per cent of the patients treated with exercise had an increase in the deformity, and 40 per cent had no change (Appendix A).

Recent work done by Stone et al.(1979), has included a nine-month exercise therapy programme for 99 subjects with scoliosis and also reported poor results. However, the results of this study showed the extent to which, under the optimal conditions outlined, therapeutic exercises were capable of correcting functional scoliosis and significant change in both body position and spinal functionality were shown after 20 weeks of treatment. The data revealed that post-treatment values were consistently smaller than pre-treatment values, suggesting that some positive changes had taken place due to the therapeutic programme. It appears that in cases of lateral asymmetries, young children have high potential for balancing the trunk muscles if the exercise intensity is well regulated and monitored. This should encourage clinicians to consider using exercise therapy as an important treatment for functional scoliosis.

A study by Schultz (1984), highlighted this potential effect of the trunk muscles in the progression or correction of idiopathic scoliosis. These authors argued that a source of progression of scoliosis is due to the inability of the trunk muscles to provide the appropriate forces to maintain an unchanged upright posture of the spine. There are several possible reasons for the controversy concerning the use of exercise therapy as an efficient treatment for scoliosis. Research on this question is complicated and to date, no study has been found which has satisfactorily controlled all variables.

Most previous studies which examined the relationships between exercise programmes and scoliosis exhibited limitations of the following type:

1. Short length of treatment.
2. Lack of individual supervision.
3. Improper exercise programme.

Extreme care was taken in the present study to control testing procedures and the conduct of the treatment programme itself. It is admissible, where other outcomes are the focus, to be less rigorous with respect to the treatment itself. Thus Stone et al.(1979), had subjects perform an active exercise programme at home with no supervision, as opposed to the individual attention given to each subject in the present study. However, it is the author's opinion that without individual supervision, no valid information on the

effect of exercise programmes on functional scoliosis can be achieved.

Another important difference between this study and previous ones (Vercautern *et al.*,1982; Avikainen and Vaherto,1983; Licht,1965) involves the testing procedures and the methodology of measuring lateral asymmetries. More rigorous measurements of the magnitude of scoliosis and lateral asymmetries than were used by these authors are needed. Thus in the present study the extent of scoliosis was determined objectively and quantitatively by using anthropometric and functional measurements as well as x-rays.

The information presented here is an attempt to show the responses of the functional scoliotic spine to an individualised and closely supervised exercise programme. This knowledge may provide a useful basis for better understanding and management of functional scoliosis, and might shed additional light on the effectiveness of exercise therapy in the treatment of this problem.

## CHAPTER 5

### SUMMARY, CONCLUSIONS AND RECOMMENDATIONS

#### AIMS

Previous studies have tended to demonstrate that in cases of functional scoliosis, postural muscle "tightness" should be assessed during musculo-skeletal examinations, and that the treatment rationale should include appropriate mobilization therapy along with improving imbalances between antagonistic muscle groups along the spine (Janda,1983; Alter,1988; Nudelman and Reis, 1990). However, no published data were found on the effect of these treatments on lateral deviations of the spine.

This study reports the results of a therapeutic intervention in cases of functional scoliosis, using methods of exercise training. After 20 weeks of intensive treatment, the findings demonstrate postural improvement of spinal functionality and reduction of Cobb's angle, spinal deviation scores and area under the scoliotic curve.

The following test hypothesis was developed: There is no change in the scoliotic curve and functionality due to an exercise therapy programme.

## **METHOD**

School-children aged 7 to 18 years (n = 1052) were examined and measured by one trained observer via the following stages:

### **A. Subjective assessment : screening programme.**

The presence or absence of the following bodily asymmetries was recorded:

- Shoulder height
- Scapular level
- Chest and hip prominence
- Lateral deviation of the spine.

The child was then asked to bend forward looking at the floor, keeping the feet together, knees braced back, shoulders loose and hands positioned between the knees. A subjective assessment of asymmetry of the upper chest, mid-chest and lower chest, the lumbar region and sacrum was made in this position. The presence or absence of a lateral spinal curvature (clinical evidence of scoliosis) was recorded.

### **B. Objective assessment:**

Subjects found to have positive physical signs underwent objective clinical examination. At this stage data were collected in the following categories:

1. Demographical data including sex, age, ethnicity, body mass, stature, and familial history of scoliosis.
2. Anthropometric measurements including height of Acromia, Bi-Acromial diameter, C<sub>7</sub>-Acromion distance, Scapula-to-Spine distance, height of Anterior Superior Iliac Spine

(ASIS), Bi-iliac diameter, Lower Limb length and S<sub>1</sub>-Acromion distance.

3. Functional measurements included trunk flexion, lateral flexion, spinal rotation, shoulder flexibility and hamstring flexibility.
4. Radiographs: Anteroposterior spinal radiographs were taken at the time of the first clinical examination. Measurements from these were made by the author as follows:
  - a. All spinal curve angles using Cobb's method.
  - b. Spinal deviation scores ( $\Sigma d/h$ ).
  - c. Area under the curve (SRD = C/A).

Informed consent was obtained from the parents of each subject prior to examination (See Appendix H).

Following the clinical examinations, each of 10 subjects was placed on a specific exercise programme, and participated in 60 treatments for 20 weeks (3 times weekly for one hour).

Following the treatment programme, the subjects were again examined. All data were analyzed using related t-tests to compare pre-treatment and post-treatment measurements.

## RESULTS

1. The exercise programme was found to exert a positive effect on asymmetries observed in the anthropometric measurements. Before treatment, the mean of the general asymmetry scores ( $E = H/L-1$ ) was 0.34 cm. After the treatment the mean was 0.06 cm indicating a significant ( $p < 0.05$ ) decrease as a result of the programme.
2. A comparison between pre- and post-treatment results of the angle of acromial asymmetry showed a significant improvement after the programme. The mean angle reduced from  $2.4^\circ$  before the treatment to  $0.1^\circ$  after the treatment.
3. The functional parameters measured before and after the treatment showed significant changes. Mean asymmetry scores in ROM of lateral flexion reduced from 2.32 cm to 0.3 cm. Asymmetry in shoulder flexibility was reduced from a mean of 4.0 cm to 1.95 cm, and differences in truncal rotation were reduced from a mean of  $3.7^\circ$  before the treatment to  $1.1^\circ$  following the treatment. Thus, the general functional asymmetries were significantly decreased by the programme ( $P < 0.05$ ).
4. The exercise programme resulted in a significant reduction in Cobb's angles as measured on x-rays, from a mean of  $11.0^\circ$  before the treatment to  $5.0^\circ$  after the treatment. The programme reduced the spinal curve in

nine subjects and did not change the curve in one. This contrasts with the results reported by Stone et al. (1979) who found no significant changes after an exercise programme of 9 months. It is probable that their negative results may be related to the fact that there was no individual supervision of the exercise programme. It is noteworthy that, by the end of Stone's programme only 59% of the subjects could remember all the exercises taught to them, and only 48% of the group could perform all of them correctly. Clearly this regimen was not sufficient and no valid conclusions can be made from this as to the effect of exercise programmes on functional scoliosis. In treating scoliosis by exercise therapy, apparently no positive effect can be achieved without close interaction between therapist and patient (if possible on a daily basis). This in fact was the conclusion reached by Stones and co-workers.

5. A mean reduction of 55.7% was measured in the area under the curve ( $SRD = C/A$ ) following personalised treatment in the present study.
6. The general spinal deviation scores ( $\Sigma d/h$ ) as measured on the x-rays were significantly lower ( $p < 0.05$ ) in the post-treatment measurements.

7. Previous school screening surveys have shown that a high proportion of the pre-pubescent and adolescent population have mild scoliotic curves. Corroborative results were not observed in this study, in which the incidence rate of scoliosis was only 1.14%.

#### CONCLUSIONS

Based upon the experimental findings of this investigation involving young scoliotic children (average age 10.6 years) the following conclusions are made:

1. The exercise programme resulted in a significant decrease in Cobb's angles and thereby positively affected spinal alignment in the treatment of scoliosis.
2. The treatment resulted in major changes in functional factors and significantly reduced all the spinal functional asymmetries which were observed in the study.
3. The therapeutic programme had a positive effect on reduction of the general asymmetry scores ( $\Sigma H/L-1$ ) as reflected in the anthropometric measurements.
4. Acromial angular asymmetry was significantly reduced due to the programme.
5. The treatment resulted in significant reductions both in the area under the curve ( $SRD = C/A$ ) and the general spinal deviation scores ( $\Sigma d/h$ ).

The findings of this study force a rejection of the null hypothesis, and support a tentative acceptance ( $p > 0.05$ ) of

the alternative hypothesis, namely; that changes in functional scoliotic curves and functionality can be achieved by a rigorous, individualised, exercise therapy programme.

#### **RECOMMENDATIONS**

1. In dealing with anthropometric methods, attention should be directed to improving and/or developing new techniques for describing the human body and measuring spinal deviations and lateral asymmetries.
2. Future study in this area would help to determine whether adaptive changes in the musculo-skeletal system relate to lifestyle, sporting or recreational influences in specific groups. A cross-sectional study may help to assess the onset of postural muscular imbalances and changes in these patterns for age/sex groups.

## REFERENCES

Adams RC and McCubbin JA (1991). Games, sports and exercises for the physically disabled, Fourth Edition. Philadelphia: Lea and Febiger, publ.,pp. 158-166.

Alter MJ (1988). Science of stretching, First Edition. Illinois: BA Brooks, pp. 17-21.

Andersson SM and Nelsson BE (1979). Changes in bone mineral content following ligamentous knee injuries. *Medicine in Sport and Science*, 11(1): 351-353.

Anciaux M, Lenaer A, Van Beneden ML, Blonde W and Vercauteren M (1991). Transcutaneous electrical stimulation (TCES) for the treatment of adolescent idiopathic scoliosis: Preliminary results. *Acta Orthopaedica Belgica*, 57(4): 399-405.

Arkin AM (1950). The mechanism of rotation in combination with lateral deviation in the normal spine. *Journal of Bone and Joint Surgery*, 32(A): 180-190.

Assente R, Ferrigno G, Pedotti A, Santambrogio GC and Vigano R (1987). AUSCAN system: A new procedure to evaluate spinal deformities. *International Series of Biomechanics*, 6(A): 206-211.

Avikainen VJ and Vaherto H (1983). A high incidence of spinal curvature. *Acta Orthopaedica Scandinavica*, 54(1): 267-273.

Basmajian JV (1978). Therapeutic exercise, Third Edition. Baltimore: Williams and Wilkins, pp. 430-447.

Basmajian JV (1967). Muscles alive: their function revealed by electromyography, Second Edition. Baltimore: Williams and Wilkins, pp. 146-157.

Bennetti GL and Podesta F (1991). Scoliosis: ten years experience of screening. *Paediatric Medicine*, 13(4): 379-385.

Blount WP and Bolincke J (1967). Physical therapy in the nonoperative treatment of scoliosis. *Physical Therapy*, 47(1): 919-925.

Brighton CT, Katz MJ and Goll SR (1985). Prevention and treatment of sciatic denervation disuse osteoporosis in the rat tibia. *Bone*, 6(1): 87-97.

Brooks HL, Azen EG, Brooks R and Chan L (1975). Scoliosis: A prospective epidemiological study. *Journal of Bone and Joint Surgery*, 57(A): 968-972.

Brown L (1988). An introduction to the treatment and examination of the spine by combined movements. *The Journal of the Chartered Society of Physiotherapy*, 74(7): 347-353.

Cailliet R (1975). *Scoliosis, First Edition*. Philadelphia: FA Davis, pp. 12-43.

Capasso G, Maffulli N and Testa V (1992). The validity and reliability of measurements in spinal deformities: a critical appraisal. *Acta Orthopaedica Belgica*, 58(2): 126-135.

Carr AJ, Ogilvie DJ, Wordsworth BP, Priestly LM, Smith R and Sykes B (1992). Segregation of structural collagen genes in adolescent idiopathic scoliosis. *Clinical Orthopaedics*, 274(1): 305-310.

Cassella MC and Hall JE (1991). Current treatment approaches in the nonoperative and operative management of adolescent idiopathic scoliosis. *Physical Therapy*, 71(12): 897-909.

Chukuka S, Enwemeka I, Bonet MI, Jayanti AI, Prudhithumrong S and Ogbahon EF (1986). Postural correction in persons with neck pain. *The Journal of Orthopaedic and Sports Physical Therapy*, 8(5): 235-238.

Cobb JR (1958). Scoliosis. *Journal of Bone and Joint Surgery*, 40(A): 510-512.

Cobb JR (1960). The problem of the primary curve. *Journal of Bone and Joint Surgery*, 42(A): 1413-1425.

Crisco JJ and Panjabi MM (1991). The intersegmental and multisegmental muscles of the lumbar spine. A biomechanical model comparing lateral stabilizing potential. *Spine*, 16(7): 793-799.

Cyriax J (1979). *Textbook of orthopaedic medicine*, 7th Edition. London: Bailliere Tindall Cassell, pp. 32-61.

Davis EC, Logan GA and Mckinney WC (1965). Biophysical values of muscular activity, Second Edition. Iowa : Brown company, pp. 30-33.

Denner F, Siegling CW, Franke J and Hochheim B (1990). Personal experiences using the cheneau brace. Beitr Orthop Traumatol, 37(7): 378-382.

Dickson RA and Sevitt EA (1982). Growth and idiopathic scoliosis: a longitudinal cohort study. Journal of Bone and Joint Surgery, 64(B): 385-386.

Droual R, Bickford AA and Farver TB (1991). Scoliosis and tibiotarsal deformities in broiler chickens. Avian Diseases, 35(1): 23-30.

Duncan NA and Ahmed AM (1991). The role of axial rotation in the etiology of unilateral disc prolapse. An experimental and finite-element analysis. Spine, 16(9): 1089-1098.

Enoka RM (1988). Neuromechanical basis of kinesiology, First Edition. Illinois: MC Davis, pp. 198-200.

Ford DM, Bagnall KM, Mcfadden KD, Greenhill BJ and Raso VJ (1984). Paraspinal muscle imbalance in adolescent idiopathic scoliosis. Spine, 9(1): 373-376.

Frischhut B and Krismer M (1990). Pelvis tilt in neuromuscular diseases. Orthopaed 19(5): 292-299.

Garret R (1987). Back strength and fitness programme using Norsk and sequence training. Journal of the Chartered Society of Physiotherapy, 73(10): 573-575.

Geissele ME, Kransdorf MJ, Geyer CA, Jelinwk JS and Van Dam BE (1991). Magnetic resonance imaging of the brain stem in adolescent idiopathic scoliosis. Spine, 16(7): 761-763.

Goldberg CJ and Dowling FE (1991). Idiopathic scoliosis and asymmetry of form and function. Spine, 16(1): 84-87.

Gustavsen R (1985). Training therapy, First Edition. New-York: Weer Goff, publ., pp. 17-32.

Haderspeck K and Schultz A (1981). Progression of idiopathic scoliosis: an analysis of muscle actions and body weight influences. *Spine*, 6(1): 447-455.

Hawley G (1949). *The kinesiology of corrective exercise*, First Edition. Philadelphia: HL Dickins, pp. 17-36.

Hay GJ and Reid GJ (1978). *The anatomical and mechanical bases of human motion*, First Edition. New-Jersey: Englewood cliffs, pp. 29-46.

Hellebrandt FA (1938). Standing - a geotropic reflex, the mechanism of the asynchronous relation of motor units. *American Journal of Physiology*, 8(3): 471-474.

Herbert MA and Bobechko WP (1985). The use of electrical stimulation of muscle to treat scoliosis in children (ESI). *International Series of Biomechanics*, 5(A): 258-260.

Houston CS (1978). The radiologist's opportunity to teach bone dynamics. *Journal of Canadian Association of Radiologists*, 29(1): 232-238.

Irvin RE (1991). Reduction of lumbar scoliosis by use of a heel lift to level the sacral base. *Journal of the American Osteopathic Association*, 9(1): 34-44.

Janda V (1983). On the concept of postural muscles and posture in man. *Australia Journal of Physiotherapy*, 29(1): 83-85.

Jarvis JG, Ashman RB, Johnston CE and Herring JA (1988). The posterior tether in scoliosis. *Clinical Orthopaedics*, 227(1): 126-134.

Kane WJ and Moe JH (1970). A scoliosis prevalence survey in Minnesota. *Clinical Orthopaedics*, 69(1): 216-218.

Keim HR (1982). *The adolescent spine*, First Edition. New York: Springer-Verlag, pp. 25-62.

Kendall F and McCreary EK (1983). *Muscles: testing and function*, Third Edition. Baltimore: Williams and Wilkins, pp. 270-285.

Keuffel K and Esser E (1963). Compensating Polar Planimeters -Instruction manual. Keuffel and Esser Co., pp. 2-13.

Kisner C and Colby LA (1985). Therapeutic exercise, Second Edition. Philadelphia: FA Davis, pp. 519-542.

Koeslag JH (1993). What is normal? South African Medical Journal, 83(1): 47-50.

Koreska J, Seebacher JR and Moseley CF (1985). Coupled motion of the spine: A study of abnormal behaviour. International Series of Biomechanics, 5(A): 252-255.

Kojima T, and Kurokawa T (1992). Quantitation of three-dimensional deformity of idiopathic scoliosis. Spine, 17(3): 22-29.

Kuprian W (1982). Physical Therapy for sports, First Edition. Philadelphia: W B Saunders Co., pp.12-43.

Licht S (1965). Therapeutic exercise, Second Edition. Baltimore: Elizabeth Licht, pp. 507-551.

Lindbeck L (1985). Analysis of functional scoliosis by means of an anisotropic beam model of the human spine. Journal of Biomechanical Engineering, 107(1): 281-285.

Loncar DM, Pecina M and Preberg Z (1991). A longitudinal study of growth velocity and development of secondary gender characteristics versus onset of idiopathic scoliosis. Clinical Orthopaedics, 270(1): 278-282.

Lonstein JE (1977). Screening for spinal deformities in Minnesota schools. Clinical Orthopaedics, 126(1): 33-42.

Lonstein JE, Bjarklund S, Wanninger MH and Nelson RP (1982). Voluntary school screening for scoliosis in Minnesota. Journal of Bone and Joint Surgery, 64(A): 481-488.

Low WD, Chew EC, Kung LS, HSU LCS and Leong JCY (1983). Ultrastructures of nerve fibres and muscle spindles in adolescent idiopathic scoliosis. Clinical Orthopaedics, 174(1): 217-221.

Martin AD, Howie JL, Bailey DA and Houston CS (1986). Osteoporosis and bone dynamics: a radiological perspective. In T Reilly, J Watkins and J Borms : Kinanthropometry, First Edition. London: E and FN Spon, pp. 3-7.

Mazess RB and Whedon GD (1983). Immobilization and bone. *Classifications Research*, 35(1): 265-267.

McKenzie R (1981). *The lumbar spine*, First Edition. Upper Hott NZ: Wright and Carmen, pp. 13-47.

McGill SM (1991). Kinetic potential of the lumbar trunk musculature about three orthogonal orthopaedic axes in extreme postures. *Spine*, 16(7): 809-815.

Miyasaki RA (1980). Immediate influence of the thoracic flexion exercise on vertebral position in Milwaukee brace wearers. *Physical Therapy*, 60(8): 1005-1009.

Murphey M, Ouale JL, Martin NL, Bramble JM, Cook LT and Dwyer SJ (1992). Computed radiography in musculoskeletal imaging: state of the art. *American Journal of Roentgenology*, 158(1): 19-27.

Nicolopoulus KS, Burwell RG and Webb JK (1985). Stature and its component in adolescent idiopathic scoliosis. Cephalo-caudal disproportion in the trunk of girls. *The Journal of Bone and Joint Surgery*, 67(13): 594-601.

Noone G, Mazumdar J and Ghista D (1991). Continuous model of the human scoliotic spine. *Journal of Biomedical Engineering*, 13(1): 473-480.

Nudelman W and Reis ND (1990). Anatomy of the extrinsic spinal muscles related to the deformity of scoliosis. *Acta Anatomica*, 139(3): 220-225.

Occhipinti E, Colombini D, Molteni G, Menoni O, Boccardi S and Grieco A (1989). Clinical and functional examination of the spine in working communities: Occurrence of alterations in the male control group. *Clinical Biomechanics*, 4(1):25-33.

Panjabi MM (1983). The human spine: story of its biomechanical functions. In A Winter, W Norman, P Wells, C Hayes and E Patla: *International Series on Biomechanics*, First Edition. Illinois: EC Hall, pp. 219-223.

Pal GP (1991). Mechanism of production of scoliosis. A hypothesis. Spine, 16(3): 288-292.

Pal GP, Bhatt RH and Patel VS (1991). Mechanism of production of experimental scoliosis in rabbits. Spine, 16(2): 137-142.

Piscopo J and Baley J (1981). Kinesiology: the Science of Movement, First Edition. New-York: John Wiley and sons, pp. 446-450.

Ponte DJ, Jensen GJ and Kent BE (1984). A preliminary report on the use of the Mckenzie protocol versus Williams protocol in the treatment of low back pain. The Journal of Orthopaedic and Sport Physical Therapy, 6(2): 130-139.

Portillo D, Sinkora G, Mcneill T, Spencer D and Schultz A (1982). Trunk strengths in structurally normal girls and girls with idiopathic scoliosis. Spine, 7(6): 551-554.

Pruijjs JE, Keessen W, Van Der Meer R, Van Wieringen JC and Hageman MA (1992). School screening for scoliosis: methodologic considerations. Part 1: External measurements. Spine, 17(4): 431-436.

Pugh J (1983). Mechanical aspects of osteoarthritis. In : A Winter, W Norman, P Wells, C Hahes and E Patla International series of biomechanics, First Edition. Illinois: JR Tompson, pp.135-139.

Risser JC and Ferguson AB (1936). Scoliosis. Journal of Bone and Joint Surgery, 18(d): 667-668.

Roaf R (1956). Paralytic Scoliosis. Journal of Bone and Joint Surgery, 38(b): 640-659.

Roaf R (1966). The basis anatomy of scoliosis. Journal of Bone and Joint Surgery, 48(B): 786-792.

Roaf R (1977). Posture, First Edition. London: Academic Press, pp. 21-72.

Rogala EJ, Drummond DS and Gurr J (1978). Scoliosis: incidence and natural history. Journal of Bone and Joint Surgery, 60(A): 173-176.

Sagal V, Shah A, Glangan N, Schaffer M, Kane W, Subramani V and Singh H (1983). Morphologic and morphometric studies of muscle in idiopathic scoliosis. *Acta Orthopaedica Scandinavica*, 54(1): 242-251.

Salter RB (1988). *Textbook of disorders and injuries of the musculoskeletal system*, Second Edition. Baltimore: Williams and Wilkins, pp. 309-316.

Samuelsson L, Lindell D and Kogler H (1991). Spinal cord and brainstem anomalies in scoliosis. MR screening of 26 cases. *Acta Orthopaedica Scandinavica*, 62(5): 403-406.

Schneider E, Niethard FU, Schiek H, Carstens C and Pfiel J (1991). How idiopathic is idiopathic scoliosis? Results of neurological studies, with somatosensory evoked potentials (SSEP) in children and adolescents. *Orthopaedics*, 129(4): 355-361.

Schultz AB (1984). Biomechanical factor in the progression of idiopathic scoliosis. *Annals of Biomedical Engineering*, 12(1): 621-630.

Shands AR and Eisberg HB (1955). The incidence of scoliosis in the State of Delaware. A study of 50 000 minifilms of the chest made during a survey for tuberculosis. *Journal of Bone and Joint Surgery*, 37(A): 1243-1249.

Siracusano G (1984). The physical therapist's use of exercise in the treatment of chronic pain. *The Journal of Orthopaedic and Sports Physical Therapy*, 6(2): 73-88.

Slupsky SH, Durdle NG, Raso VJ, Hill DL and Peterson AE (1992). A video digitizer for analysis of trunk deformity in scoliosis. *Journal of Biomedical Engineering*, 14(1): 69-72.

Smith GL, Odwyer KD, Lin SY and Blanpied RP (1991). The effect of trunk resistive exercise on muscle strength in post-menopausal women. *The Journal of Orthopaedic and Sports Physical Therapy*, 13(6): 300-309.

Smith LR, Sebastian BA and Gajdosik RL (1988). Effect of sacroiliac joint mobilization on the standing position of the pelvis in healthy man. *The Journal of Orthopaedic and Sports Physical Therapy*, 10(3): 77-80.

Somerville EW (1952). Rotational lordosis: the development of the single curve. *Journal of Bone and Joint Surgery*, 34(B): 421-427.

Steindler A (1964). *Kinesiology of the human body under normal and pathological conditions, Second Edition.* Springfield: Charles C Thomas Publishers, pp. 241-254.

Stokes IA and Gardner MM (1991). Analysis of the interaction between vertebral lateral deviation and axial rotation in scoliosis. *Journal of Biomechanics*, 24(8): 753-759.

Stokes IA (1991). Biomechanical Testing and Scoliosis: In Vivo Methods. *Spine*, 16(10): 1217-1223.

Stone B, Beekman C, Hall V, Guess V and Brooks L (1979). The effect of an exercise program on change in curve in adolescents with minimal idiopathic scoliosis. *Physical Therapy*, 59(6): 759- 763.

Tarr I (1948). Analysis of normal and scoliotic spine. *Physiotherapy*, 28(1): 6-10.

Taylor JR (1983). Scoliosis and growth. Patterns of asymmetry in normal vertebral growth. *Acta Orthopaedica Scandinavica*, 54(1): 596-602.

Tompson CW (1989). *Manual of structural kinesiology, Eleventh Edition.* Boston: Times Mirror, pp. 51-83.

Torell G, Nordwall A and Nachemson A (1981). The changing pattern of scoliosis treatment due to effective screening. *Journal of Bone and Joint Surgery*, 63(A): 337-341.

Vercautern M, Van Benden M, Verplaetse R, Croene P, Uyttendaele D and Verdonk R (1982). Trunk asymmetries in a Belgian school population. *Spine*, 7(6): 555-562.

Wagner H (1990). Pelvis tilt and leg length correction. *Orthopade*, 19(5): 273-277.

Wells F K and Luttgens K (1976). *Kinesiology, 6th Edition.* Philadelphia: WB Saunders company, pp. 403-405.

White AA (1971). Kinematics of the normal spine as related to scoliosis. *Journal of Biomechanics*, 4(1): 405-411.

White A A and Panjabi M M (1978). *Clinical biomechanics of the spine*. First Edition. Philadelphia: J B Lippincott, pp. 2-55.

Winthrop MP, Kiphuth JH and Goff CW (1956). *The diagnosis and treatment of postural defects*, First Edition. Baltimore: Wilkins, pp. 13-71.

Wolff J (1892). *The law of bone transformation*, First Edition. Berlin: Hirschwald, pp. 13-46.

Worthington V and Shambaugh P (1991). Systemic abnormalities in idiopathic scoliosis. *Journal of Manipulative Physiology Therapy*, 14(8): 467-471.

Wynarsky GT and Shultz AB (1991). Optimization of skeletal configuration: studies of scoliosis correction biomechanics. *Journal of Biomechanics*, 24(8): 721-732.

Zernicke RF, Gregor RJ and Cratty BJ (1982). Balance and visual proprioception in children. *Journal of Human Movement Studies*, 8(1): 1-13.

## APPENDIX A

### Statement of the American Academy of Orthopaedic Surgeons - 1974:

The American Academy of Orthopaedic Surgeons hereby gives its official recommendation to any programme of routine evaluation of school children for the detection of scoliosis and other crippling spine deformities. The Academy recognises that by early detection, more appropriate treatment can be given and better total treatment of this disability healthy problem can be carried out.

(Adams and McCubbin, 1991)

## APPENDIX B

Dear Parents/Guardians,

There will be a screening programme for scoliosis for all pupils aged 7 through 18.

Scoliosis is defined as a condition for the spine in which the spine may curve to the left or right. It is most commonly found during the time of rapid growth and may progress if it is not treated. The purpose of the screening programme is to recognise scoliosis in its earliest stages.

Your son/daughter will be advised in advance of the exact date of his/her screening.

Female pupils are requested to wear a two-piece bathing suit or a halter and shorts. Male pupils will be evaluated in shorts.

If your child is suspected of a possible scolioses, you will be given written notice with a recommendation for further evaluation by a physician or specialist.

If you, for any reason, have any objections to this scoliosis screening of your child, please notify the school your child attends, in writing, at your earliest convenience.

Thank you for your co-operation.

Sincerely,

Gill Solberg,  
Exercise Therapist.

APPENDIX C

DEPARTMENT OF HUMAN MOVEMENT STUDIES

RHODES UNIVERSITY

SCREENING TESTS

NAME: \_\_\_\_\_ AGE: \_\_\_\_\_ STATURE: \_\_\_\_\_ cm

MASS: \_\_\_\_\_ DATE: \_\_\_\_\_ SEX: \_\_\_\_\_ M \_\_\_\_\_ F

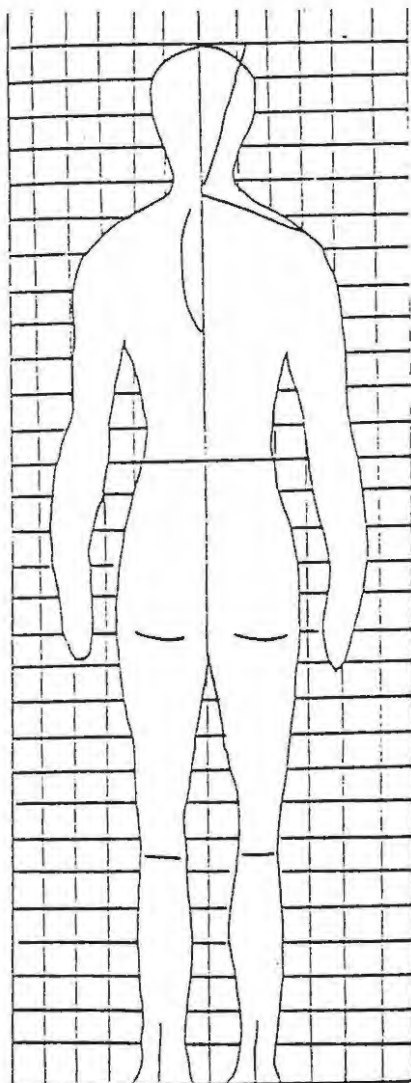

		1	2	3	4
HEAD TILT -	(R)	—	—	—	—
	(L)	—	—	—	—
SHOULDER LEVEL (HIGHER)	(R)	—	—	—	—
	(L)	—	—	—	—
UPPER SPINE (DORSAL) (CURVE)	(R)	—	—	—	—
	(L)	—	—	—	—
SCAPULA (HIGHER)	(R)	—	—	—	—
	(L)	—	—	—	—
RIBS (PROMINENT)	(R)	—	—	—	—
	(L)	—	—	—	—
LOWER SPINE (LUMBAR) (CURVE)	(R)	—	—	—	—
	(L)	—	—	—	—
ILIAC RESTS (HIGHER)	(R)	—	—	—	—
	(L)	—	—	—	—

FORWARD BENDING TEST: RIB HUMP - Y N

SIDE - L R

GENERAL INFORMATION AND RECOMMENDATIONS: \_\_\_\_\_

**APPENDIX D**  
**MEASUREMENT FORM**

Name: \_\_\_\_\_ Age: \_\_\_\_\_ Stature: \_\_\_\_\_ cm

Mass: \_\_\_\_\_ Sex: \_\_\_\_\_ M \_\_\_\_\_ F Date: \_\_\_\_\_ Time: \_\_\_\_\_

Handedness : R/L

1	ANTHROPOMETRIC MEASUREMENTS		Left	Right	Lateral Asymmetry
a	Height of acromia				
b	Height of inferior angle				
c	Height of ASIS				
d	Acromial diameter				
e	L <sub>5</sub> - S <sub>1</sub> acromia distance	Standing			
		forward flexion			
f	Bi-iliac diameter				
g	Scapulae-to-spine distance				
h	C <sub>7</sub> - acromia distance				
i	Lower Limb Length				
2	FUNCTIONAL MEASUREMENTS				
a	Trunk flexion - Thoracolumbar spine		standing:	Forward Flexion:	
b	Lateral bending				
c	Shoulder flexibility right elbow up left elbow up				
d	Spinal rotation				
e	Abdominal muscle strength				
f	Hamstring flexibility test				
3	X-Rays:		a. Cobb Angle b. Area under curve (SRD=C/A) c. Vertebral deviation (SD=Σ d/H)		

APPENDIX E

FIVE MEASUREMENTS OF AREA UNDER THE CURVE USING PLANIMETER

MEASUREMENT NUMBER	RESULT
1	46.80
2	47.80
3	48.20
4	47.10
5	45.90
$\bar{X}$	47.16
SD	0.8014
CV	1.69

COEFFICIENT OF VARIATION (CV) - ANTHROPOMETRIC MEASUREMENTS:

No	Height of Acromia	Height of Inferior Angle	Height of (PSIS)	Height of (ASIS)	L <sub>5</sub> -S <sub>1</sub> Acromia Distance	C <sub>7</sub> -Acromia Distance	Lower Limb Length	Scapula-Spine Distance	Biacromial Diameter
1	103.8	93.0	73.7	71.5	47.0	15.0	67.5	3.6	30.0
2	103.7	93.2	73.7	71.5	47.2	15.1	67.5	3.6	30.1
3	103.8	93.2	73.5	71.6	47.2	15.0	67.6	3.7	30.0
4	103.9	93.1	73.4	71.5	47.0	15.0	67.7	3.5	30.2
5	103.8	93.1	73.6	71.7	47.0	15.1	67.6	3.6	30.1
6	103.7	93.0	73.7	71.6	47.1	15.0	67.5	3.7	30.0
7	103.9	92.9	73.8	71.6	46.9	15.2	67.7	3.5	29.9
8	103.9	92.9	74.0	71.6	46.8	14.9	67.6	3.6	29.9
9	103.7	93.1	73.8	71.7	47.1	14.9	67.7	3.6	30.0
10	103.8	93.2	73.7	71.7	46.9	14.8	67.5	3.5	29.8
$\bar{x}$	103.8	93.07	73.69	71.62	47.05	15.0	67.59	3.590	30.0
SD	0.0774	0.11	0.1577	0.0979	0.1857	0.1095	0.0830	0.0700	0.1095
CV	0.0007	0.0011	0.0021	0.0013	0.0039	0.0073	0.0012	0.0194	0.0036
CV %	0.07	0.11	0.21	0.13	0.39	0.73	0.12	1.94	0.36

APPENDIX G

COEFFICIENT OF VARIATION (CV) - FUNCTIONAL MEASUREMENTS:

NO	TRUNK FLEXION (CM)	LATERAL BENDING (CM)	SPINAL ROTATION (degrees)	SHOULDER FLEXIBILITY (CM)	HAMSTRING FLEXIBILITY (degrees)
1	44.0	31.5	36	9.0	85
2	44.2	31.7	38	8.5	86
3	44.1	31.4	36	8.8	84
4	43.9	31.7	37	8.9	87
5	44.3	31.6	39	8.8	85
6	44.2	30.8	38	9.1	85
7	44.0	30.9	39	9.0	86
8	44.1	31.2	40	9.0	84
9	43.9	31.0	37	8.9	86
10	43.8	31.4	35	8.9	87
$\bar{x}$	44.05	31.32	37.5	8.9	85.5
SD	0.15	0.3124	1.5	0.1549	1.0246
CV	0.0034	0.0099	0.04	0.0174	0.0119
CV%	0.34	0.99	4.00	1.74	1.19

## APPENDIX H

### EXERCISE THERAPY PROGRAMME

General information for parents-

The Department of Human Movement Studies at Rhodes University is conducting a special exercise programme which has been established as part of the Department's activities.

The main objectives of our programme are to serve some of the special needs of local children through specific physical activities. The method is to improve the child's general abilities, as well as giving a sports framework.

As part of this unique programme, we measured your child in initial screening tests, and have found slight asymmetric posture. Therefore, we would like to offer him/her participation in these specific exercise sessions, because we strongly feel that such a programme may improve his/her general physical abilities and positively influence his/her bodily development.

Personalised attention is given by an experienced exercise therapist, working in close association with senior medical and academic staff of the Department.

Prior to the beginning of the programme, various clinical examinations (including x-rays) will be done.

Please note that since the programme consists of only 60 sessions, the children will be requested to participate in all of them.

---

#### INFORMED CONSENT

I \_\_\_\_\_ having been fully informed of the nature of the rehabilitative procedure to be instituted in the Department of Human Movement Studies at Rhodes University, do hereby give my consent to the administration of such procedures.

Signature: \_\_\_\_\_

Date: \_\_\_\_\_



## APPENDIX J

### THERAPEUTIC EXERCISES

1. (a) Prone position.  
(b) Arms at sides.  
(c) Elbows straight.  
(d) Palms of hands upward.  
(e) Pull scapulae together.  
(f) Do not move shoulders.  
(g) Hold.  
(h) Return to starting position.
2. (a) Prone position.  
(b) Arms at sides.  
(c) Elbows straight.  
(d) Palms of hands upwards.  
(e) Raise arms to 45° angle.  
(f) Do not move shoulders.  
(g) Hold.  
(h) Return to starting position.
3. (a) Prone position.  
(b) Place hands in the small of the back.  
(c) Palms of hands upward.  
(d) Raise elbows and shoulders.  
(e) Do not move head.  
(f) Hold.  
(g) Return to starting position.
4. (a) Prone position.  
(b) Arms at sides.  
(c) Elbows straight.  
(d) Raise head, shoulders and chest.  
(e) Hold.  
(f) Return to starting position.
5. (a) Prone position.  
(b) Arms at shoulder level at a right angle to the body.  
(c) Elbows straight.  
(d) Palms of hands facing downward.  
(e) Raise arms.  
(f) Hold.  
(g) Return to starting position.
6. (a) Supine position.  
(b) Knees flexed, feet flat on floor.  
(c) Tilt pelvis backward.  
(d) Force lower back flat against floor.  
(e) Contract abdominal muscles.  
(f) Hold.  
(g) Return to starting position.

7.
  - (a) Supine position.
  - (b) Knees bent, feet flat on floor.
  - (c) Roll pelvis backward.
  - (d) Try to force lower back flat against floor.
  - (e) Contract abdominal muscles.
  - (f) Lift head and shoulders upward, touch knees with fingertips.
  - (g) Hold.
  - (h) Return to starting position.
  
8.
  - (a) Supine position.
  - (b) Legs out straight.
  - (c) Bend both knees to 90°.
  - (d) Grasp with hands. Pull knees to chest.
  - (e) Hold.
  - (f) Return to starting position.
  
9.
  - (a) Supine position.
  - (b) Knees flexed, feet flat on floor.
  - (c) Arms extended overhead.
  - (d) Slowly raise arms forward toward knees.
  - (e) With chin to chest, raise the upper body 45°.
  - (f) Hold.
  - (g) Lower slowly.
  - (h) Return to starting position.
  
10.
  - (a) Supine position.
  - (b) Knees flexed, feet flat on floor.
  - (c) Arms folded across chest.
  - (d) Contract abdominal muscles.
  - (e) Slowly raise the upper body to a semi-sitting position.
  - (f) Hold at approximately a 45° angle.
  - (g) Lower slowly.
  - (h) Return to starting position.
  
11.
  - (a) Supine position.
  - (b) Knees flexed, feet flat on floor.
  - (c) Hands clasped behind head.
  - (d) Elbows back.
  - (e) Contract abdominal muscles.
  - (f) Slowly raise the upper body to a semi-sitting position.
  - (g) Hold at 45° angle.
  - (h) Lower slowly.
  - (i) Return to starting position.
  
12.
  - (a) Supine position.
  - (b) Hips and knees flexed.
  - (c) Feet flat on floor.
  - (d) Inhale through nose to maximum.
  - (e) Hold briefly.
  - (f) Exhale slowly.
  - (g) Repeat.

13. (a) Supine position.
- (b) Hips and knees flexed.
- (c) Feet flat on floor.
- (d) Place one hand on each side of
- (e) Inhale through nose. Try to elevate chest only.
- (f) Hold briefly.
- (g) Exhale.
- (h) Abdomen should remain fairly still during exercise.
- (i) Repeat.

**Specific exercises for scoliosis:**

**The following exercises are designed for a left C scoliosis, as an example, and can be adjusted to any specific case.**

14. (a) Prone position.
  - (b) Pelvis is stabilized.
  - (c) Left arm reach toward the knee, while right arm is stretched up and overhead.
  - (d) Hold.
  - (e) Return to starting position,
15. (a) Prone position.
  - (b) Hands behind the head.
  - (c) Lift head and trunk and bend the trunk to the left side.
  - (d) Hold.
  - (e) Return to starting position.
16. (a) Heel sitting (to stabilize the lumbar curve).
  - (b) Lean forward with abdomen resting on the thighs.
  - (c) Arms stretched overhead bilaterally.
  - (d) Hands are flat on the floor.
  - (e) Bend the trunk to the left by "walking" the hands to the convex side of the curve.
  - (f) Hold.
  - (g) Return to starting position.
17. (a) Quadruped (four-legged) position.
  - (b) Extend right leg with simultaneous overhead extension of the right arm.
  - (c) Hold.
  - (d) Return to starting position.
18. (a) Side-lying position, over the edge of a mat table on the convex (left) side.
  - (b) A rolled towel at the apex of the convexity.
  - (c) Lumbar spine is stabilized by the therapist.
  - (d) Top arm (right side) stretched overhead.
  - (e) Hold.
  - (f) Return to starting position.

19. (a) Side lying position on the concave (right) side.  
(b) Pelvis is stabilized by therapist.  
(c) With lower arm across the chest, the patient rotates the trunk, lifts up the head and shoulders (lateral trunk bending) and slides the top arm down to the knee.  
(d) Hold.  
(e) Return to starting position.

