

**AN EXPLORATION OF THE PRIOR CONCEPTUAL UNDERSTANDING OF
MEASUREMENT OF FIRST YEAR NATIONAL CERTIFICATE (VOCATIONAL)
ENGINEERING STUDENTS**

A thesis submitted in fulfilment of the requirements for the degree of

DOCTOR OF PHILOSOPHY

of

RHODES UNIVERSITY

by

PAMELA VALE

March 2017

ABSTRACT

Measurement is acknowledged to be a critical component in mathematics education and is particularly important for vocational Engineering students, for whom this is a key skill required in the workplace. The goal of this research was to explore the existing measurement conceptualisations of vocational Engineering students at the outset of their course, as evident in their engagement with mediated measurement tasks. The focus on students' prior knowledge in measurement, was for the value that this awareness holds in understanding the learning needs of the students.

Students participated in five measurement tasks. Four took the form of dynamically assessed task-based interviews, and the fifth was a written test assessing what they had learned during their Mathematics classes. Domains of measurement that were assessed in these tasks included length, area, surface area, volume and flow rate. The interviewer took the role of mediator and students were assessed according to the number of moments of mediation and the degree of mediation required to successfully complete the task. Students' responsiveness to this mediation provided insight as to their conceptualisations of the measurements relevant to the task.

This research was exploratory in nature and adopted an open and flexible approach to the data analysis. Critical incidents were identified and coded according to the mediation offered and the actions of the students during the measuring activity. This allowed patterns to emerge that revealed stable and emerging conceptualisations that related to embodied and symbolic aspects of measurement. Evidence was found that for many of these students the link between the embodied and symbolic aspects of the concept was broken. This insight allowed suggestions to be formulated about how better to facilitate these students' learning of measurement.

TABLE OF CONTENTS

LIST OF FIGURES	xiii
LIST OF TABLES	xvii
CHAPTER 1: INTRODUCTION	1
1.1 Introduction	1
1.2 Rationale for the research	1
1.3 The measurement research context	3
1.3.1 The measurement research context in 2016	3
1.3.1.1 Measurement research in conference proceedings	4
1.3.1.2 Measurement research in mathematics education journals	5
1.3.2 Increasing attention to measurement teaching and learning	7
1.3.3 The needs in measurement research	8
1.4 Research questions	8
1.5 Organisation of content	9
1.6 Use of terminology	10
CHAPTER 2: CONTEXT	13
2.1 Introduction	13
2.2 The vocational education landscape in South Africa	13
2.2.1 Addressing the critical need for artisans	14
2.2.2 TVET and the triple problems of unemployment, inequality and poverty	15
2.2.3 Rationale for the TVET focus of this research	16
2.3 The National Certificate (Vocational)	17
2.3.1 The position of the NC(V) in the National Qualifications Framework	18
2.3.2 Vocational education and combined approaches to formal education	20
2.3.3 Pathways to the workplace and further training available to NC(V) graduates ..	20
2.3.3.1 Seven steps to trade certification as an artisan	21
2.3.3.2 Pathways to further study post-NC(V)	23
2.3.3.3 Pathways to the workplace as a professionally registered engineer	25
2.3.4 The importance of mathematics at every level of engineering work	26
2.4 Shifts in approaches to TVET research in South Africa	26
2.4.1 Distinct research periods	27
2.4.1.1 The Period of Reconstruction	27

2.4.1.2	The Period of Early Critique	27
2.4.1.3	Shifting policy discourse	28
2.4.2	Educational research in a time of measurement	28
2.4.3	Taking a fresh approach to TVET research	30
2.5	What do we know about the TVET sector?	30
2.5.1	Performance in Mathematics	30
2.5.2	Developing the skills of Mathematics lecturers	32
2.5.3	Asking new questions	32
2.6	Prior schooling in context	33
2.6.1	The quintile system in South Africa	33
2.6.2	All grade passes are not equal	35
2.6.3	Acknowledging prior knowledge	36
2.7	Measurement learning across curricula	37
2.7.1	Measurement as crucial to engineering practice	37
2.7.2	Expected trajectory of measurement learning	38
2.7.2.1	Measurement learning in the Intermediate and Senior Phases	39
2.7.2.2	Measurement learning in ABET Level 4	40
2.7.2.3	Measurement learning in the FET Band	40
2.7.2.4	Technical Mathematics	41
2.7.3	Measurement learning in NC(V) Level 2 Engineering programmes	41
2.7.4	Summary of measurement foci per curriculum	42
2.8	Summary	43
 CHAPTER 3: LITERATURE REVIEW		 45
3.1	Introduction	45
3.2	Piaget and fundamental thinking about measurement	46
3.2.1	Piaget's four stages of development	47
3.2.2	Piaget and learning	48
3.2.3	Some critiques of Piaget's theory	49
3.2.4	Piaget in the context of this research	50
3.3	David Tall and the development of mathematical thinking	50
3.3.1	Skemp and the formation of mathematical concepts	50
3.3.2	David Tall and the development of mathematical thinking	51
3.3.2.1	Proceptual thinking	52

3.3.2.2	The development of mathematical thinking	52
3.3.3	Applying Tall's theory to measurement	54
3.3.3.1	Classifying measurement tasks	55
3.3.3.2	Using Tall to understand the measurement learning trajectory	59
3.4	Measurement	60
3.4.1	What is object measurement?	61
3.4.2	Units in measurement	62
3.4.3	Rational numbers in measurement	63
3.4.4	Estimation	64
3.4.5	Conceptual and procedural knowledge in measurement	65
3.4.6	Domains of measurement in this research	66
3.4.6.1	Area measurement	66
3.4.6.2	Volume measurement	70
3.4.6.3	Measurement of rates	72
3.5	Vygotsky and the process of concept formation	76
3.5.1	The role of words in concept formation	76
3.5.2	The process of concept formation	77
3.5.3	Scientific and everyday concepts	78
3.5.4	Concept development in mathematics	79
3.5.5	Signs and tools	80
3.5.6	The zone of proximal development	81
3.5.7	A note on mediation	82
3.5.8	Conceptualisation of the act of measuring for this research	82
3.6	Dynamic assessment	84
3.6.1	What is dynamic assessment?	84
3.6.2	Approaches to dynamic assessment	84
3.6.3	Problems with quantification and the solutions offered by computer-based tests	85
3.6.4	The application of dynamic assessment in this research	87
3.7	Reconsidering the use of Piaget and Vygotsky	88
3.8	Mediated measurement interaction	89
3.9	Summary	90

CHAPTER 4: METHODOLOGY	91
4.1 Introduction	91
4.2 Research questions	91
4.3 Research approach	92
4.3.1 Research paradigm	92
4.3.1.1 Interpretivism as a research position.....	92
4.3.1.2 Constructivism	93
4.3.2 Ontology, epistemology and methodology	99
4.3.2.1 Realism as ontology	99
4.3.2.2 Constructivist epistemology	99
4.3.2.3 Interpretivist methodology	99
4.3.2.4 Qualitative approach.....	100
4.3.3 Exploratory research	101
4.3.4 Case study research	101
4.3.5 Position of the researcher	102
4.3.5.1 Participant-observer	103
4.3.5.2 Unobtrusive nonparticipant observation	103
4.3.6 Summary of research approach	104
4.4 Research design	104
4.4.1 Site selection and participants	104
4.4.1.1 Sampling methods	105
4.4.1.2 Sample group demographics	106
4.4.1.3 Contextual influences on sample selection	109
4.4.2 Methods	109
4.4.2.1 Task-based interviews	110
4.4.2.2 Dynamic assessment design of task-based interviews	111
4.4.2.3 Video-recordings	114
4.4.2.4 Formal written test	116
4.4.3 A summary of the research design	116
4.5 Data analysis	117
4.5.1 Overall approach	117
4.5.2 Analysing the task-based interviews	117
4.5.2.1 First steps in processing raw data	118
4.5.2.2 The inductive process	119

4.5.2.3	The role of critical incident analysis	122
4.5.2.4	Basic and emergent mediation codes	123
4.5.3	Analysing the written test	125
4.5.4	A summary of data analysis techniques.....	125
4.6	Validity and reliability	125
4.6.1	Persistent observation	126
4.6.2	Triangulation	126
4.6.3	Leaving an audit trail	127
4.6.4	Member checking	127
4.6.5	Clarifying researcher bias	127
4.6.6	Peer debriefing	128
4.6.7	Rich and thick description	129
4.6.8	Quantitising qualitative data	130
4.6.9	Summary of approach to ensuring trustworthiness	131
4.7	Ethical considerations	131
4.8	Summary	133
 CHAPTER 5: THE FIVE MEASUREMENT TASKS		135
5.1	Introduction	135
5.2	Task One: Measuring the area of an irregular surface	136
5.3	Task Two: Measuring the volume of a cube	138
5.4	Task Three: Measuring volumetric flow rate	139
5.4.1	Subtasks 1 and 2	140
5.4.2	Subtasks 3 and 4	142
5.5	Task Four: Collaborative area measurement task	143
5.5.1	The question	144
5.5.2	Mediation	145
5.5.3	The interview process	146
5.6	Task Five: Formal written test	147
5.7	Summary	149
 CHAPTER 6: PRESENTATION AND ANALYSIS OF DATA: INTERVIEWS 1 & 2 ...		151
6.1	Introduction	151
6.2	Process of summary and analysis	151

6.2.1	Summary and analysis of Task 1	151
6.2.2	Summary and analysis of Task 2	153
6.3	Data presentation and analysis: Task 1	153
6.3.1	General summary of task performance	154
6.3.2	Summary of work in Task 1, Phase 1	158
6.3.2.1	Strategies used in Phase 1	158
6.3.2.2	Mediation provided in Phase 1	161
6.3.3	Summary of work in Task 1, Phase 2	164
6.3.3.1	Strategies used in Phase 2	164
6.3.3.2	Mediation provided in Phase 2	165
6.3.4	Summary of work in Task 1, Phase 3	169
6.3.5	Summary	170
6.4	Data presentation and analysis: Interview 2	171
6.4.1	General summary of task performance	171
6.4.2	Student definitions of volume	172
6.4.3	Summary of work in Task 2, Phase 1	174
6.4.4	Summary of work in Task 2, Phase 2	175
6.4.5	Summary	177
6.5	Stable and emerging conceptualisations	178
6.5.1	Stable conceptualisations	178
6.5.2	Emerging conceptualisations	179
6.5.3	Additional insights	179
6.6	Summary	179
 CHAPTER 7: PRESENTATION AND ANALYSIS OF DATA: INTERVIEW 3		181
7.1	Introduction	181
7.2	Process of summary and analysis	181
7.3	Data presentation and analysis: Subtasks 1 and 2	182
7.3.1	General summary of performance: Subtasks 1 and 2	182
7.3.2	Performance in Subtask 1	183
7.3.3	Predictions for Subtask 2	187
7.3.4	Performance in Subtask 2	188
7.3.5	Summary	190
7.4	Data presentation and analysis: Subtasks 3 and 4	190

7.4.1	General summary of task performance: Subtask 3	191
7.4.1.1	Student predictions for Subtask 3	191
7.4.1.2	Subtask 3, Question 1	194
7.4.1.3	Subtask 3, Question 2	198
7.4.2	General summary of task performance: Subtask 4	199
7.4.2.1	Student predictions for Subtask 4	200
7.4.2.2	Subtask 4, Question 1	204
7.4.2.3	Subtask 4, Question 2	207
7.4.3	Summary	207
7.5	Stable and emerging conceptualisations	207
7.5.1	Stable conceptualisations	208
7.5.2	Emerging conceptualisations	208
7.5.3	Additional insights	208
7.6	Summary	209
 CHAPTER 8: PRESENTATION AND ANALYSIS OF DATA: INTERVIEW 4		211
8.1	Introduction	211
8.2	Process of summary and analysis	211
8.3	Data presentation and analysis	212
8.3.1	General comparison of performance between Tasks 1 and 4	212
8.3.2	Analysis of performance per task	214
8.3.2.1	Interview summary: Ndileka	214
8.3.2.2	Interview summary: Mzwakhe	216
8.3.2.3	Interview summary: Nobuhle	218
8.3.2.4	Interview summary: Sisipho	219
8.3.2.5	Interview summary: Ntando	220
8.3.2.6	Interview summary: Neliswa	222
8.3.2.7	Interview summary: Aviwe	223
8.3.2.8	Interview summary: Sandla	225
8.3.2.9	Interview summary: Kaden	227
8.3.2.10	Interview summary: Malusi	228
8.3.2.11	Summary	229
8.3.3	Analysis of performance per task phase	230
8.3.3.1	Mediation in Task Phase 1	230

8.3.3.2	Mediation in Task Phase 2	231
8.3.3.3	Mediation in Task Phase 3	232
8.3.3.4	Mediation in Task Phase 4	233
8.3.3.5	Mediation in Task Phase 5	234
8.3.4	Summary	235
8.4	Stable and emerging conceptualisations	235
8.4.1	Stable conceptualisations	235
8.4.2	Emerging conceptualisations	236
8.4.3	Additional insights	237
8.4.3.1	The influence of the key member's performance in Task 1	237
8.4.3.2	Student talk and strategizing	237
8.4.3.3	The value of the contextual richness.....	237
8.4.3.4	Evidence of development	238
8.5	Summary	238

CHAPTER 9: PRESENTATION AND ANALYSIS OF DATA: FORMAL WRITTEN TEST

9.1	Introduction	239
9.2	Process of summary and analysis	239
9.2.1	Initial summary and analysis	239
9.2.2	Categories of responses	240
9.2.2.1	Use of formulae	241
9.2.2.2	Categories emerging during analysis of work with correct formula use	242
9.2.2.3	Categories emerging during analysis of work with incorrect formula use ..	244
9.2.3	Use of SI units	245
9.3	Data presentation and analysis	247
9.3.1	Overall test results	247
9.3.2	Performance per item	247
9.3.2.1	Volume	248
9.3.2.2	Area	249
9.3.2.3	Length	250
9.3.3	The use of formulae	251
9.3.3.1	Use of the formula sheet	252
9.3.3.2	Types of errors	253
9.3.4	Properties of shapes	255

9.3.5	Use of SI units	256
9.3.6	Summary	257
9.4	Stable and emerging conceptualisations	257
9.4.1	Stable conceptualisations	258
9.4.2	Emerging conceptualisations	258
9.4.3	Additional insights	258
9.5	Summary	258
CHAPTER 10: DISCUSSION AND CONCLUSION		259
10.1	Introduction	259
10.2	An overview of the insights from Tasks 1 to 5	259
10.2.1	Tasks 1 and 2	260
10.2.1.1	Task 1: Area measurement	260
10.2.1.2	Task 2: Volume measurement	261
10.2.2	Task 3	262
10.2.3	Task 4	263
10.2.4	Task 5	263
10.3	Stability and emergence as evident in students' engagement in the measurement tasks	
10.3.1	Research Questions 1 and 2	264
10.3.2	Discrete strands of knowledge and the broken link	266
10.4	Facilitating the construction of stable and accurate measurement conceptualisations	268
10.4.1	Tall and the broken link	269
10.4.2	Tasks 3 and 4 and the development of measurement conceptualisations	271
10.5	Strengths and contributions of the research	272
10.6	Limitations	273
10.7	Implications of the study	273
10.8	Avenues for further research	274
10.9	Reflection	274
REFERENCES		275
APPENDICES		299
A:	Survey of PME Research Reports	301

B:	Survey of Measurement Research in 5 Peer-Reviewed Mathematics Education Journals	303
C:	NC(V) Engineering Programmes of Study	307
D:	NQF Level Descriptors: Levels 1 - 4	311
E:	General Descriptions of Measurement Learning for Intermediate Phase, Senior Phase & ABET L4	315
F:	Curriculum Progression of Measurement Learning (Intermediate Phase & Senior Phase)	317
G:	Curriculum Progression of Measurement Learning (FET Phase Maths, Math Lit & Technical Maths)	322
H:	Curriculum Progression of Measurement Learning (FET Phase Math Lit)	323
I:	Measurement Learning in NC(V) Mathematics Level 2 And NC(V) Engineering Technology Level 2	327
J:	Mediated measurement interaction model	329
K:	Summary of Research Approach	331
L:	Basic Student Demographic Information	333
M:	Tasks completed by each student	335
N:	Levels of Mediation	337
O:	Consent Document	339
P:	Map of Holiday Resort	341
Q:	Formal Written Test	343
R:	Formula Sheet	346
S:	Scans of work from Task 1	347
T:	Summary of performance on Task 1	355
U:	Summary of performance on Task 2	357
V:	Detailed summary: Task 3, Subtask 1	359
W:	Detailed summary: Task 3, Subtask 2	363
X:	Detailed summary: Task 3, Subtask 3	365
Y:	Detailed summary: Task 3, Subtask 4	369
Z:	Performance per test item	375
AA:	Detailed summary of use of incorrect formulae	377
	GLOSSARY OF ABBREVIATIONS AND ACRONYMS	379

LIST OF FIGURES

1.1	Timelines representing research reported at PME and ICME conferences and published in 5 peer-reviewed mathematics education journals	7
2.1	Seven steps to becoming an artisan	22
2.2	Pathways to further training for NC(V) engineering graduates	24
2.3	Pathways to the engineering workplace per NQF exit level	25
2.4	Distribution of schools by province and quintile	34
2.5	Average grade 8 mathematics test scores for middle income countries participating in TIMSS 2011	35
3.1	Tall's organisation of mathematical thinking and development	54
3.2	Grade 4 and Grade 5 ANA test items	55
3.3	Introducing the calculation of volume in a Grade 6 workbook	56
3.4	Grade 7 ANA test item	56
3.5	Grade 9 ANA test items	57
3.6	Grade 12 Mathematics NSC examination item	57
3.7	Grade 12 Mathematical Literacy NSC examination item	58
3.8	Application of Tall to the measurement learning trajectory in South African school curricula	59
3.9	Tall's diagonal development trajectory	60
3.10	Iteration of unit (B)	61
3.11	Row and column subdivision	67
3.12	Over and Back user interface	74
3.13	Sign and tool mediation	81
3.14	The individual engaging in measuring activity	83
3.15	Interaction with the mediator in the mediated measurement task	87
3.16	The mediated measurement interaction model	89
4.1	Complexities of the second continuum	96
4.2	Continuum 1: Individual psychology vs Public discipline	98
4.3	Continuum 2: Nature as instructor vs Humans as creators	99
4.4	Continuum 3: Individual cognition vs Social and political processes	99
4.5	Age of student participants	107
4.6	Number of students per qualification level	108
4.7	Quintile status of schools previously attended by participants	109

4.8	Students per NC(V) programme	109
4.9	The position of the mediator	113
4.10	Basic levels of mediation	114
4.11	Observer and participant perspectives in video-recording	116
4.12	Observer perspective and framing of video of interview 4	116
4.13	Parallel data collection and analysis	119
4.14	Timing of data analysis	119
4.15	The composition of the interview narrative	120
4.16	First level of coding of the narrative	121
4.17	Process of constant comparison	122
4.18	List of basic and emergent mediation levels and types	125
5.1	The question: Measure the area of the surface using the tile as a unit	137
5.2	Student working on Task 1	137
5.3	The question: Measure the volume of the block using the small cube as a unit	138
5.4	Student working on Task 2	139
5.5	Cylindrical container used for Task 3	139
5.6	Student and interviewer participating in Task 3	140
5.7	Task 3, Subtask 1	141
5.8	Task 3, Subtask 2	141
5.9	Task 3, Subtask 3	142
5.10	Task 3, Subtask 4	143
5.11	Map of holiday resort	144
5.12	Information card	145
5.13	Artefact cards containing area formulae	146
6.1	Areas measured in Phase 1 and Phase 2 (lower-bound strategy)	152
6.2	Areas measured in Phase 1 and Phase 2 (upper-bound strategy)	153
6.3	Strategies used in Task 1, Phase 1	159
6.4	Strategy type: Other	161
6.5	Mediation in Task 1, Phase 1	162
6.6	Student work: Ndileka	163
6.7	Strategies used in Task 1, Phase 2	165
6.8	Mediation in Task 1, Phase 2	166
6.9	Whole number bias: An example	167
6.10	Evidence of unstable knowledge	168

6.11	Student work: Neliswa	168
6.12	Student work: Malume	169
6.13	Mediation in Task 1, Phase 3	170
6.14	Mediation in Task 2, Phase 1	174
6.15	Malusi: Rectangular array	175
6.16	Mediation in Task 2, Phase 2	177
7.1	Mediation provided during Subtask 1	184
7.2	Student predictions for Subtask 2	187
7.3	Mediation provided during Subtasks 1 and 2	189
7.4	Position of holes for Subtask 3	191
7.5	Subtask 3: Number of utterances/gestures referring to each variable	198
7.6	Subtasks 1 – 3, Question 2: Mediation provided.....	199
7.7	Position of holes for Subtask 4	200
7.8	Comparison of student predictions: Subtasks 3 and 4	202
7.9	Subtask 4: Number of utterances/gestures referring to each variable	206
8.1	Moments of mediation and levels of mediation: Task 4, Phase 1	230
8.2	Moments of mediation and levels of mediation: Task 4, Phase 2	231
8.3	Moments of mediation and levels of mediation: Task 4, Phase 3	232
8.4	Moments of mediation and levels of mediation: Task 4, Phase 4	233
8.5	Moments of mediation and levels of mediation: Task 4, Phase 5	235
9.1	Emergent categories of test item responses	241
9.2	Correct use of the formula (Item 1.1a)	242
9.3	Correct use of a self-generated formula (Item 3.1b)	242
9.4	Substitution error (Item 3.3b)	243
9.5	Technical error (Item 3.4b)	243
9.6	Incomplete solution (Item 3.2b)	243
9.7	Formula applied for the incorrect shape (Item 1.1a)	244
9.8	Formula applied for the incorrect property (Item 1.2)	244
9.9	Application of an invalid formula (Item 3.3b)	245
9.10	Volume formula applied for an item requiring surface area (3.3b)	245
9.11	Surface area applied for an item requiring distance (2.2)	245
9.12	Incorrect exponent (Item 3.1a)	246
9.13	Incorrect unit (Item 3.1a)	246
9.14	Incorrect unit and exponent	246

9.15	Results of formal written test	247
9.16	Categories of responses according to use of formulae	251
9.17	Correct and incorrect responses per formula source	252
9.18	Substitution error (Item 3.3b)	254
9.19	Substitution error (Item 3.4a)	254
9.20	Substitution error (Item 1.1b)	255
9.21	Use of units when reporting solutions	257
10.1	Broken links between the conceptual/embodied and procedural/symbolic	268
10.2	Tall's developmental model	269
10.3	The measurement learning trajectory in South African school curricula	270
10.4	The integration of knowledge strands during complex activity	272

LIST OF TABLES

1.1	Research focus of reports on measurement education research at PME conferences (2006 - 2016)	4
1.2	Research focus of articles on measurement education research in 5 peer-reviewed mathematics education journals	6
2.1	The South African National Qualifications Framework	18
2.2	Percentage of students passing NC(V) mathematics from 2011 to 2014	31
2.3	Summary of measurement foci per curriculum	43
3.1	Area measurement progression	67
3.2	Volume measurement progression	70
3.3	Key differences between the theories of Piaget and Vygotsky	88
6.1	Task 1, Phase 1 strategies	154
6.2	Task 1, Phase 2 strategies	156
6.3	Student solutions to Task 2	176
7.1	General summary of performance: Task 3, Subtasks 1 and 2	183
7.2	Summary of predictions: Subtask 3	192
7.3	Summary of use of keywords: Subtask 3	195
7.4	Summary of predictions: Subtasks 3 and 4	200
7.5	Summary of use of keywords: Subtask 4	205
8.1	Number of moments and highest level of mediation: Task 1 vs Task 4	213
8.2	Summarised moments of mediation per task phase: Ndileka	215
8.3	Summarised moments of mediation per task phase: Mzwakhe	217
8.4	Summarised moments of mediation per task phase: Nobuhle	218
8.5	Summarised moments of mediation per task phase: Sisipho	220
8.6	Summarised moments of mediation per task phase: Ntando	221
8.7	Summarised moments of mediation per task phase: Neliswa	222
8.8	Summarised moments of mediation per task phase: Aviwe	224
8.9	Summarised moments of mediation per task phase: Sandla	225
8.10	Summarised moments of mediation per task phase: Kaden	227
8.11	Summarised moments of mediation per task phase: Malusi	229
9.1	Rating scale	240
9.2	Summary of student performance per item	248
10.1	Stable and emerging conceptual/embodied and procedural/symbolic knowledge ..	265

Dad,
this will always be for you



ACKNOWLEDGEMENTS

I would like to acknowledge and thank Rhodes University for the funding provided to me through a Rhodes University Prestigious Scholarship. I was very proud to have been awarded this scholarship, and am similarly proud to now count myself as a graduate of this university.

To Dr Bruce Brown, my supervisor: Your patient guidance and supervision throughout this project have been instrumental in my reaching this point. I cannot thank you enough for the enthusiasm you maintained for this work.

To the Mathematics lecturers who welcomed me into their classrooms, and the students who so willingly participated in this project: I am deeply indebted to you for your generosity in sharing your space and time. I hope that this research does justice to our work together.

To my family: Charles Vale, Gail Vale, Monica Coetzee and Justin Coetzee... your unwavering belief that I could complete this project kept me going through all the rough patches. Mom, your strength inspires me – this was a hard journey for you too, and I thank you so much for always being there.

And to Hannah... you have been the light that has kept us all going!

CHAPTER 1

INTRODUCTION

1.1 INTRODUCTION

Sarama, Clements, Barrett, van Dine and McDonel (2011, p. 667) emphasise that “measurement is a critical component of mathematics education”, but explain that research on the learning and teaching of measurement is limited. This study aims to contribute research to this developing field, with a specific focus on the measurement learning of vocational engineering students at a South African Technical and Vocational Education [TVET] college.

The goal of this research is to explore the existing measurement conceptualisations of TVET Engineering students at the outset of their course, as evident in their engagement with mediated measurement tasks. The focus on students’ prior knowledge in measurement, is for the value that this awareness holds in understanding the needs of the students. This insight provides the foundation from which suggestions can be formulated about how to support the students’ further development of accurate and stable measurement conceptualisations most effectively.

In this chapter, a brief rationale for the focus of the research is provided, as well as an overview of the measurement research landscape. This highlights the need for measurement research that focuses on students beyond primary school age, and on measurement domains beyond those of length, area and volume. Thereafter, the research aims and questions are made explicit.

Finally, an outline of the thesis is provided, as well as technical notes explaining the ways in which various terms are used in this thesis.

1.2 RATIONALE FOR THE RESEARCH

‘Measurement’ is included in the list of engineering functions defined by the Engineering Council of South Africa [ECSA] (ECSA, 2014). Competence in measurement is therefore a key skill in the engineering workplace. Furthermore, as Johri and Olds (2011) point out, “what engineers need is adaptive expertise which allows them to be innovative and efficient in what they do” (p. 174). Therefore, the measurement learning of these students needs to be sufficient to allow for adaptive use of these concepts and skills.

There is a need for improving the teaching and learning of Mathematics in the TVET sector. The pass rate for the subject is yet to exceed 50% (Department of Higher Education and Training [DHET], 2015a), suggesting that students are not acquiring adaptive expertise in the concepts and skills that ought to be learned in this subject. Having taught Mathematics at a TVET college, I have observed students as they have struggled with the subject and have experienced the frustration of not knowing how to support their needs, nor understanding what these needs may be. The concern deepens when the concepts and skills learned in the Mathematics classroom translate directly into workplace competencies required in their chosen field as is the case with measurement for students of engineering.

As explained in Section 1.3, there is a paucity of research that speaks to any of the aspects of this challenge in vocational education. Research on the teaching and learning of measurement remains limited, particularly research focusing on issues of measurement learning beyond primary school years and beyond the spatial object measurements of length, area and volume. Adult vocational measurement learning, which extends to measurements more complex than spatial measurement, is left largely unexamined. In terms of understanding the TVET student, there is as yet no South African research that works at the student-level to attempt to understand their specific learning needs (this claim is substantiated in Chapter 2). This research aims to contribute to filling those gaps.

Students entering TVET colleges have a minimum of a Grade 9 qualification, and are at least 16 years of age (Further Education and Training [FET] Round Table, 2010). This implies that in their everyday lives, as well as through their schooling, students would have had exposure to informal and formal opportunities to conceptualise measurement. What this research proposes is that an understanding of the prior knowledge and existing measurement conceptualisations these students hold as they enter TVET courses can lead to more efficient and effective teaching and learning of measurement, and in so doing enable the student to develop the adaptive expertise that would be expected in the workplace.

1.3 THE MEASUREMENT RESEARCH CONTEXT

As mentioned, Sarama et al. (2011) claim that mathematics education research in the field of measurement learning is limited, despite the important role that measurement plays in mathematics.

Owens and Outhred (2006), in the *Handbook of Research on the Psychology of Mathematics Education* (Gutiérrez & Boero, 2006), provide an overview of research conducted in the field of measurement. They surveyed the research presented at each of the International Group for the Psychology of Mathematics Education's [PME] 30 annual international conferences, spanning the period 1976 – 2006, and noticed that the growth of the body of research about measurement was initially slow. They found that the first appearance of a paper focused on measurement was six years after the first conference, in 1982 (see Eisenberg, Goldstein & Gorodetsky, 1982). The focus of this paper is not on practical measuring, but rather on how to teach conversions (Eisenberg et al., 1982). The first appearance of 'Measurement' as a separate section in the Table of Contents of the PME proceedings was only in 1987 and the first (and, to-date, only) plenary related to measurement was held as late as 2003 (Owens & Outhred, 2006).

Beyond noting that the growth of the field had been slow, Owens and Outhred (2006) write that there was almost no research reported in the PME proceedings for measurement of non-spatial quantities. Fundamental to the measurement of length, area and volume is an understanding of "the spatial organisation of the units, in one, two or three dimensions respectively" (p. 100). Studies in measurement have historically predominantly focused on the "structure of units when measuring the spatially-organised attributes of length, area and volume" (p. 105), with an emphasis on length and area. Students' development of volume concepts had received less attention, possibly due to the complexity of its three-dimensional nature (Owens & Outhred, 2006), and the measurement of non-spatial quantities had received almost no attention.

1.3.1 The measurement research context in 2016

A literature survey was conducted to establish the state of the field beyond 2006. The conference proceedings of two international mathematics education conferences were surveyed as well as articles published in five selected mathematics education journals.

1.3.1.1 Measurement research in conference proceedings

Research reports from PME conferences after 2006, as well as those from International Congress on Mathematics Education [ICME] conferences were surveyed and the result revealed a similar pattern to that presented by Owens and Outhred (2006).

Of the 16 PME research reports about measurement, only 2 included consideration of non-spatial quantities: mass (McDonough & Cheeseman, 2014) and time (Doig, William, Wo & Pampaka, 2006). Also, noteworthy among the research reports surveyed was their singular focus on young children and primary school learners.

Appendix A provides a full list of the conference proceedings consulted and the research reports surveyed. The table below provides a summary of the foci of the research.

Table 1.1 Research focus of reports on measurement research at PME conferences (2006 – 2016)

Category	Focus	Frequency
Person-characteristics	Young children (up to Grade 3)	5
	Primary School learners (Grades 4 – 7 learners)	10
Measurement domains and concepts	Length	5
	Area	4
	Estimation	4
	Units	4
	Volume	3
	Mass	1
	Time	1

A similar picture is evident when surveying the research presented at the International Congress on Mathematics Education [ICME] Conferences, held every four years, spanning the years 1969 to 2008 (Furinghetti & Giacardi, 2012). Measurement as a distinct topic of discussion appears as a regular lecture concerning children's understanding of basic measurement in the

proceedings of the 9th conference (Fujita, Hashimoto, Hodgson, Peng, Lerman & Sawada, 2004; Vistro-Yu, 2000). No such topic appears in the 10th conference (Niss, 2008) nor the 11th (ICME, 2007). Its reappearance as a separate Topic Study Group in the 12th (Cho, 2015) and the 13th ICME (ICME, 2016), remained exclusively focused on primary education.

1.3.1.2 Measurement research in mathematics education journals

The *International Journal of Mathematics Education ZDM* published a special issue in October 2011: Learning, Teaching and Using Measurement. In the introduction to this issue, Smith, van den Heuvel-Panhuizen and Teppo (2011) wrote that the aim of the issue was to stimulate more researchers to consider working in the field of measurement learning, noting that this field requires growth.

More than half of the papers in this special edition addressed various aspects of length, area and volume measurement, which supports Owens and Outhred's (2006) contention that spatially-organised quantities are the dominant focus in PME research. Only one paper (Lehrer, Min-Joung & Jones, 2011) focuses specifically on measurement of a different type: statistics. A further paper examines German primary school students' achievement in measurement, with a view not only of their measurement of spatial quantities, but also the measurement of mass and duration (Hannighofer, van den Heuvel-Panhuizen, Weirich & Robitzsch, 2011). This reflects what is shown in the survey of research reports in PME and ICME conference proceedings.

To uncover the pattern of measurement research published in peer-reviewed mathematics education journals, five journals were identified and surveyed in the same manner as the conference proceedings (see Appendix B outlining the criteria for the selection of these journals).

The selected journals were:

<u>International</u>	Educational Studies in Mathematics Journal for the Research of Mathematics Education The International Journal for Mathematics Education ZDM
<u>African</u>	African Journal for Research in Mathematics, Science and Technology Education
<u>South African</u>	Pythagoras

In total, 53 such articles were found (see Appendix B for the full list and the inclusion criteria for the journals). The table below summarises the research foci of these articles.

Table 1.1 Research focus of articles on measurement education research in 5 peer-reviewed mathematics education journals

Category	Focus	Frequency
Person-characteristics	Young children (up to Grade 3)	16
	Primary School learners (Grades 4 – 7 learners)	21
	High School learners (Grades 8 – 12)	6
	Adults	4
Measurement domains and concepts	Length	19
	Area	17
	Units	14
	Volume	8
	Angles	6
	Estimation	4
	Perimeter	3
	Time	3
	Rate	2
	Temperature	1
Measurement in the workplace	Teachers' competence in measurement	4
	Technology and engineering	2

The research presented in these journal articles covered a wider variety of measurement domains and concepts than those found in the conference research reports surveyed. The measurement of spatial quantities, however, still features most prominently and the dominant focus remains with young children and primary school learners.

1.3.2 Increasing attention to measurement teaching and learning

If the surveyed information is organised chronologically, there is an indication of an increase in the amount of research about measurement teaching and learning. Figure 1.1 below shows two timelines extending from 1970 to 2016. The top timeline provides the numbers of articles found in the 5 journals surveyed, while the bottom timeline provides information about measurement-related research reported at PME and ICME conferences.

Figure 1.1 Timelines representing measurement research reports and articles

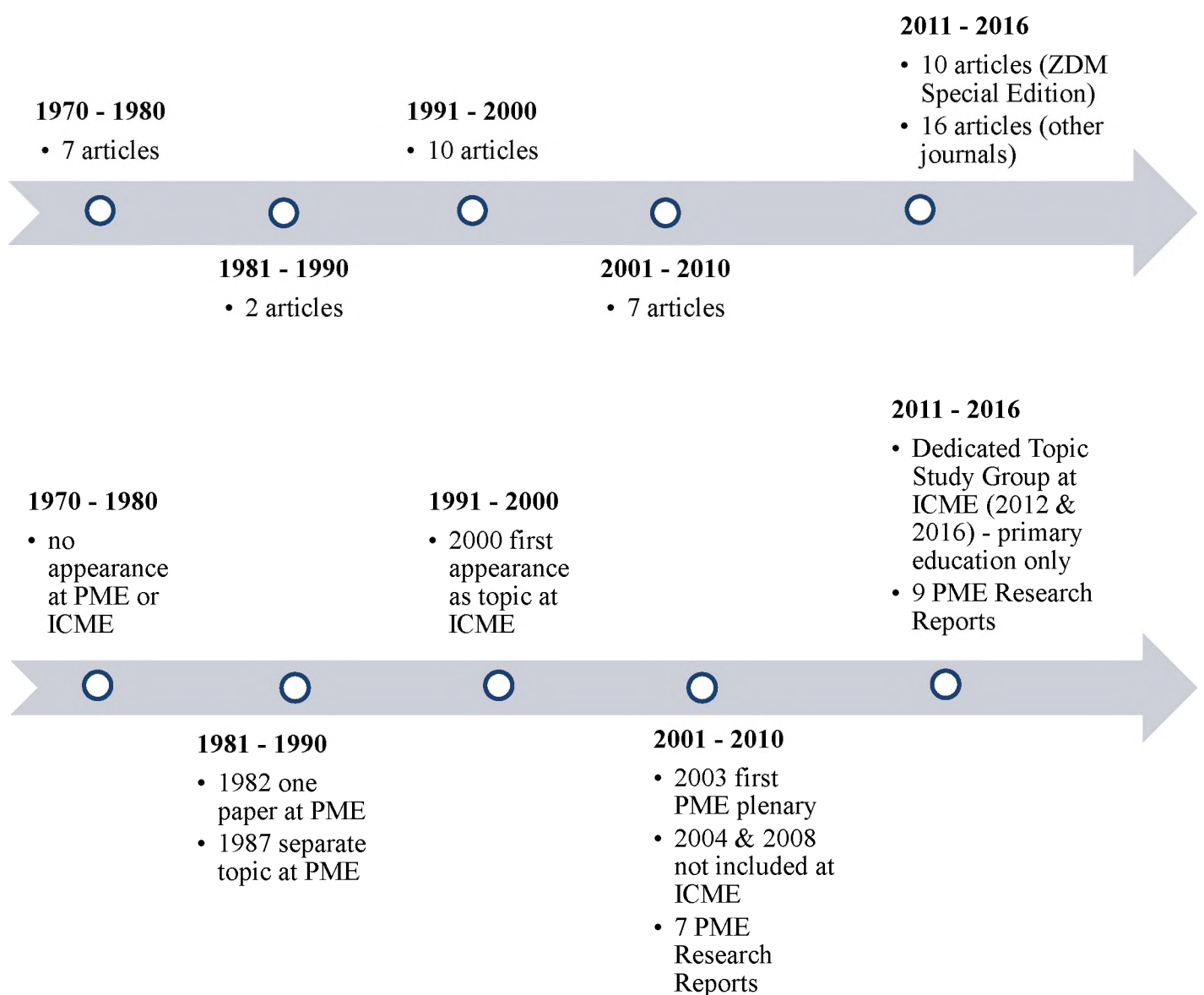

While there is an increase in articles and research reports from 2011 onwards, there is no significant shift in the focus of this research.

1.3.3 The needs in measurement research

It is clear from Owens and Outhred's (2006) review of the PME research proceedings over thirty years, from a historical review of PME and ICME proceedings, and from an overview of the selected mathematics education journals, that further research is required in the field of measurement. While the field is expanding, the focus of such research must expand beyond the spatially-organised quantities of length, area and volume, as well as beyond primary education.

This research examines the measurement conceptualisations of vocational engineering students, a field not yet explored in any of these publications. In addition, while the measurement of area and volume are required in some of the task-based interviews, there is also a focus on the measurement of flow rate, similarly not yet explored in the publications considered in this survey.

While the choice to restrict the survey to English-language journals and proceedings does introduce limitations to the findings of the survey, it was necessary to do so for pragmatic reasons. An expansion of this survey to include journals published in other languages, may reveal more of an interest in measurement at later stages of education in non-English language speaking countries. However, it is not within the scope of this thesis to conduct such a survey.

1.4 RESEARCH QUESTIONS

This research first explores the measurement conceptualisations of students entering a TVET Engineering programme, through collaboratively framed task-based interviews centred around measurement tasks. The first two questions address what these conceptualisations are, and which of these are stable and which are in the process of emerging. Insights gained through analysis of students' engagement with the mediated measurement tasks are then synthesised and evaluated to formulate suggestions about how to better facilitate students' construction of accurate and stable measurement conceptualisations.

The research questions are as follows:

1. What stable measurement conceptualisations are evident in students' engagement with mediated measurement tasks?
2. What partial or emerging measurement conceptualisations are evident in students' engagement with mediated measurement tasks?

3. Therefore, based on the analysis of stability and emergence as evident in students' engagement in the mediated measurement tasks, where does the break between what is needed as stable conceptualisations, but rather possess as emergent conceptualisations, occur?

1.5 ORGANISATION OF CONTENT

In this chapter, the rationale for the research focus on measurement has been provided. In addition, the measurement-related mathematics education research context has been outlined through a broad survey of research presented at PME and ICME conferences and published in a selection of peer-reviewed mathematics education journals. This allowed the identification of a need for research into the measurement teaching and learning of students beyond primary school age, and the need for a focus on domains of measurement beyond the spatial quantities of length, area and volume. Lastly, the questions that this research aims to answer were clarified.

Chapter 2 describes the broader educational context in which this research takes place: The South African TVET sector. The vocational education landscape in South Africa is a complex one. There are a multitude of societal and economic needs that the TVET colleges have been tasked with satisfying, while simultaneously rapidly growing their enrolment numbers. There have also been many significant historical shifts in vocational education in South Africa that have influenced the composition of their qualifications and their current position in the National Qualifications Framework [NQF]. These, and similar, complexities are explained in Chapter 2.

This research focuses particularly on Engineering students. These students will enter the engineering workplace either to train further as artisans, or as students towards professional engineering qualifications. The workplace context into which these students will move is also considered in this chapter, with a focus on why mathematics in general, and measurement in particular, are crucial to their success in these endeavours.

In addition to describing the vocational education landscape, it is necessary to describe the schooling context that these TVET students will have experienced prior to entering vocational education. To this end, Chapter 2 includes a discussion of the socioeconomic influences on the quality of schooling in South Africa, and the Mathematics performance of South African learners when compared to their international counterparts.

Finally, as the mathematical focus in this research is on measurement, an examination of measurement learning across South African curricula includes Chapter 2.

Chapter 3 presents the theoretical framing of the study, in which the theories of Vygotsky and Piaget are presented, and their contributions explained. The neo-Piagetian work of David Tall similarly influences the understanding of measurement in this research, and his work is discussed and its application described. This chapter closes with a model proposed for mediated measurement interaction which brings together the work of these theorists as they are included in this research.

In Chapter 4 the research methodology is described. It opens with a statement of the goals and research questions, which is followed by an explanation of the ontological, epistemological and methodological position of the research. The details of the research design are then provided and a full discussion of validity and reliability considered. Finally, ethical concerns are addressed

Where Chapter 4 provides a general overview of the measurement tasks students engaged in, Chapter 5 is included to provide a brief, but detailed, description of each of these. Data from observations made as students engaged in these tasks is presented and analysed in Chapters 6 to 9.

In Chapter 10 the data from each of these tasks is synthesised to provide answers to the research questions. The major findings of the research are discussed, and these extend beyond answering the research questions. Thereafter, the strengths and limitations are discussed. The contributions of the study and the implications of its findings are then outlined before a discussion of the avenues for further research that have been identified.

The thesis closes with a personal reflection on the research process, its findings and the way forward.

1.6 USE OF TERMINOLOGY

The following technical notes pertain to the use of terminology in this thesis:

- As per South African norms, ‘learners’ shall refer to school-going children from Grade R to Grade 12. ‘Students’ is used when referring to individuals attending ABET colleges, TVET colleges and other tertiary education institutions.

- Where the words ‘Mathematics’, ‘Engineering’ and ‘Level’ are used to indicate subjects and programmes, they are capitalised.
- The term ‘domain of measurement’ is used in this thesis to indicate a type of measurable quantity and its measurement, e.g. length, area, time, mass, duration and rate are all quantities that can be measured and are, as such, ‘domains of measurement’.
- Where reference is made to ‘measuring’, it is the practical use of equipment to measure physical quantities that is referred to. Where reference is made to ‘calculation’, the use of formulae and definitions to calculate a measurement, in the absence of the object to which the measurement applies, is referred to.

CHAPTER 2

RESEARCH CONTEXT

2.1 INTRODUCTION

In this chapter, the TVET college sector in South Africa is described, with a focus on the National Certificate (Vocational) [NC(V)] Engineering programmes, as this is the broad educational context in which this research is situated. The way in which these qualifications contribute to addressing the critical shortage of artisans that South Africa is facing is also explained. In addition, the schooling system in South Africa is discussed, as this is the context in which students will have first formally encountered measurement in their mathematics learning.

In terms of mathematics education research, the context in which this research is positioned is that of measurement learning of adult vocational engineering students. Included, therefore, in the description of the research context is an analysis of the mathematics and related school curricula that students will have been exposed to. This takes the form of a curriculum mapping of the progression of measurement learning through schooling and into the NC(V) Mathematics curriculum, within the context of the NC(V) Engineering programmes. This does not indicate whether learning has taken place but is important to examine as it is the expected measurement learning trajectory within the South African schooling context.

As the chapter unfolds, the gaps in the existing research are made explicit, including an explanation as to how this research aimed to contribute toward filling them.

2.2 THE VOCATIONAL EDUCATION LANDSCAPE IN SOUTH AFRICA

The TVET sector was declared by the DHET as its area of highest priority in the White Paper for Post-School Education and Training, approved by Cabinet on 20 November 2013 (DHET, 2013h). The stated purpose of these colleges is to “provide training for the mid-level skills required to develop the South African economy” (DHET, 2012c, p. 11) and the South African government claims to be seeking to meet “government delivery imperatives in skills development and employment creation” (p. 11). In South Africa, there has been a historical emphasis on the value of attending a university, however, South Africa’s status as a developing

country means that “technical skills are more important than professional university degrees” (Makholwa, 2015, p. 1).

In the following two sections, the critical need for artisans in South Africa, as well as the problems of unemployment, inequality and poverty are discussed. This discussion focuses on how TVET colleges, and the NC(V) programmes they offer, aim to contribute towards addressing these issues.

2.2.1 Addressing the critical need for artisans

The National Skills Development Strategy III [NSDSIII] (DHET, 2012c) states that the critical skill shortage South Africa is facing in the artisanal fields jeopardises the development and growth of the economy. Forty-seven of the 100 careers currently in high demand in South Africa are artisanal (South African Government News Agency, 2016). Therefore, in addition to elevating the TVET sector in general to the Post-School Education and Training area of highest priority, the South African government has “elevated and identified as a priority area for skills development” (p. 1) the need for artisans.

The shortage of artisans is most critical in the construction, engineering, mining, manufacturing and energy fields. In addition to fulfilling the role of training artisans, TVET colleges have been tasked with dramatically increasing their output in this regard from the 12 000 artisans produced in 2014 to a targeted 30 000 per annum by 2030 (Kolver, 2014) to further address this shortage.

In the South African Skills Development Amendment Act (Republic of South Africa [RSA], 2012), an artisan is defined as a “person who has been certified as competent to perform a listed trade” (p. 16). A trade is defined as:

An occupation wherein a qualified person applies a high level of practical skills supported and re-enforced [*sic*] by underpinning and applied knowledge to:

- Manufacture, produce, service, install or maintain tangible goods, products or equipment in an engineering and/or technical work environment
- Uses [*sic*] tools and equipment to perform [*sic*] of his/her duties
- *Measure* [emphasis added] and do fault finding on processing, manufacturing, production and/or technical machinery and equipment to apply corrective or repair actions

- Apply and adhere to all relevant health, safety and environmental legislation (p. 17)

Most trades listed in the Act are related to the key areas of economic growth targeted in the National Development Plan [NDP] (National Planning Commission [NPC], 2012), which include: “establish[ing] a competitive base of infrastructure; establish[ing] effective, safe and affordable public transport; produc[ing] sufficient energy to support industry; access to clean, running water; [and] increasing exports” (p. 24). It is the Engineering programmes offered at TVET colleges that prepare students to work toward artisanship in trades related to these targeted economic growth areas.

To supply the number of workers required to achieve the growth targets, the NDP (NPC, 2012) specifies that the TVET college graduation rate needs to increase to 75% by 2030, and the DHET has called for the enrolment head-count to increase from the 702 383 students in 2014 (DHET, 2016c) to 2.5 million in 2030 (DHET, 2013h). To drive these increases, the DHET declared 2014 – 2024 to be the Decade of the Artisan. This includes “campaign, interactive community events...held every three months at different TVET engineering campuses” (Kolver, 2014, p. 1). These are aimed at increasing the number of young people seeking to enrol in programmes that lead to the engineering-related artisanal careers that are most needed for the South African economy to grow.

It is the opinion of the DHET that the lack of qualifying artisans can also be addressed through improving the current quality of career guidance (Sota, 2014). This is being addressed through an Artisan Development Technical Task Team instituted by the Human Resource Development Council of South Africa [HRDCSA] with the aim to encourage school-going learners to willingly choose to attend TVET colleges and train as artisans (HRDCSA, 2016). The Decade of the Artisan also includes a drive to recruit more students into the specific trades that are most needed for the South African economy to grow.

2.2.2 TVET and the triple problems of unemployment, inequality and poverty

In addition to the economic growth imperatives mentioned above, “the TVET sector is required to play a role in addressing the triple problems of unemployment, inequality and poverty” (Rasool & Mahembe, 2014, p. 28). There is a need to “subscribe to a broader developmental agenda beyond the rigidly economic development approach” (p. 30) and as such, the colleges have been tasked by the South African government with “redress[ing] past discrimination and

ensur[ing] representivity and equal access [as well as] provid[ing] optimal opportunities for learning” (Select Committee on Education and Recreation, 2006, p. 2).

One of their purposes is to facilitate access to education for all adults, thereby enhancing their employability or providing an opportunity to access further studies at a tertiary level. In the first quarter of 2016, the official national unemployment rate was 26.7% (Statistics South Africa [StatsSA], 2016). In the Eastern Cape, where this research took place, the rate was slightly higher at 28.6% and, in the municipality in which this research was positioned even higher at 33.2% (StatsSA, 2016).

The scale of the problem of unemployment among the youth in South Africa is particularly vast. In 2013, young people (16 – 25 year olds) who were not in education, employment or training [NEETs] made up 71% of the unemployed population and the national youth unemployment rate was as high as 52.9% (StatsSA, 2013). Census data from StatsSA (2016) for the first quarter of 2016 revealed that youth unemployment had increased nationally to 67.3%.

Every year, approximately 400 000 matriculants do not move on to further studies (Rasool & Mahembe, 2014). More than 30% of these students do not find employment, therefore swelling the number of NEETs by approximately 120 000 annually (StatsSA, 2013). For young people who have not completed 12 years of schooling, the unemployment rate is 42%. However, obtaining a non-degree post-school qualification, such as those offered by TVET colleges, decreases unemployment to 16% (Rasool & Mahembe, 2014).

Young adults who have either not successfully completed 12 years of schooling, or who have completed their schooling without qualifying for entry to a university, can access the programmes at TVET colleges. This allows a ‘second chance’ at obtaining a qualification that will allow them access to the workplace. In this way, the number of NEETs in South Africa can be decreased.

2.2.3 Rationale for the TVET focus of this research

TVET colleges and the programmes they offer are core to many economic and development goals in South Africa, as explained in the previous two sections. It is their growth that has the potential to see the realisation of these goals. The growth targets for these colleges are exceptionally large, however, if these are realised, the number of artisans will be sufficient to

meet the NDP goals and it is possible that the number of NEETs and the unemployment rate in the country will be drastically reduced. This is, however, dependent on a simultaneous improvement in the quality of the instruction offered.

There is a risk that this dramatic increase could adversely affect the quality of graduates and caution needs to be taken to avoid this. The current shortage of artisans is partly due to the poor quality of artisan training in the past (Makholwa, 2015). It is also noted by the HRDCSA (2016) that the quality of teaching in TVET colleges remains poor and has resulted in a high dropout rate among students. In addition to the drive for increased output, therefore, it is necessary to have research that is focused on the classroom level. This research aims to contribute at that level by exploring the existing knowledge of first-year TVET engineering students with the view that this can inform and improve teaching.

The rationale for locating this research in the TVET sector was in part due to the contribution that these colleges can make to the South African economy, as well as to the lives of the individuals who enrol in the programmes offered. Accordingly, the HRDCSA (2016, p. 3) emphasises that “[t]he future for artisans is bright”.

2.3 THE NATIONAL CERTIFICATE (VOCATIONAL)

The National Certificate (Vocational) is one type of qualification offered at TVET colleges. It was developed to be a “sister qualification” (Umalusi, 2010, p. 10) to the National Senior Certificate [NSC]. The NC(V) is a three-year, full time course. Students enrol for one of 19 fields of study, among them 8 related to engineering (see Appendix C for the full list of NC(V) engineering programmes), and complete one National Qualifications Framework [NQF] level per year, with the final year’s study being at NQF Level 4 (DHET, 2013h).

The rationale for introducing the NC(V) curriculum, as outlined by Umalusi (2010), is to provide an alternative to the NSC qualification, which will equip students with both the theoretical background and practical experience required to master a trade or technical skill.

The following sections will describe the positioning of the NC(V) in the South African NQF. The various pathways to both the workplace and further studies available to NC(V) graduates will also be outlined. This will provide orientation as to how the NC(V) programmes produce graduates who are ready to master a trade or ready to pursue further studies in their field.

2.3.1 The position of NC(V) in the National Qualifications Framework

At NQF Level 4, a student’s scope of knowledge in their field includes a “fundamental knowledge base of the most important areas of [the] field or discipline” (South African Qualifications Authority [SAQA], 2012, p. 7). They are also able to “demonstrate the ability to apply essential methods, procedures and techniques in [this] field or discipline” (p. 7). A full list of level descriptors for Levels 2, 3 and 4 are provided as Appendix D.

The table below provides a general outline of the South African NQF:

Table 2.1 The South African National Qualifications Framework

NQF LEVEL	QUALIFICATION TYPE
10	PhD
9	Master’s Degree
8	Bachelor’s Honours Degree Post-Graduate Diploma
7	Bachelor’s Degree Advanced Diploma
6	National Diploma Advanced Certificate
5	Higher Certificate
4	Grade 12 (National Senior Certificate) NC(V) Level 4
3	Grade 11 NC(V) Level 3
2	Grade 10 NC(V) Level 2
1	Grade 9 Adult Basic Education and Training [ABET] Level 4
Senior Phase	Grades 7 – 9
Intermediate Phase	Grades 4 – 6
Foundation Phase	Grades R – 3

Adapted from SAQA (2012), Miles (2009) and Kizito (2014)

The pre-requisite for entrance to NC(V) is a qualification at NQF Level 1. This is achieved either through completion of compulsory schooling (Grade 9), or through completing the Adult Basic Education and Training [ABET] Level 4 qualification. ABET is an alternative route to NQF Level 1 for adults who did not complete compulsory schooling. Its primary purpose is to “seek to connect literacy with basic (general) adult education on the one hand and with training

for income generation on the other hand” (Department of Education, 2007, p. 5). There are four levels to the ABET qualification, and upon completion of these the student becomes eligible to enter the NC(V).

Although the entrance requirement is a qualification at NQF Level 1, students enter the course with qualifications at any of the Levels 1 to 4. In 2009, as many as 50% of students enrolled in TVET college were in possession of a NSC (DHET, 2012a).

NC(V) students therefore fall into 4 broad categories (FET Round Table, 2010):

- Young people who have a Grade 12 ‘pass’
 - Young people who have not passed Grade 12 due to either dropping out or failing the examinations
 - Young people who have left school at Grade 9 and choose enter the NC(V) route as an alternative to the NSC
 - Adults who have not completed compulsory schooling and choose to access further education. This requires:
 - ABET Level 4
- OR
- Recognition of Prior Learning [RPL] enable access to the NC(V) programmes in such cases

SAQA (2013, p. 5) defines RPL as the “principles and processes through which the prior knowledge and skills of a person are made visible, mediated and assessed for the purposes of alternative access and admission, recognition and certification, further learning and development”.

Within the first two categories, one can distinguish between students who have chosen to enrol at a TVET college because of a genuine desire to work or study further in their chosen field and those who have enrolled because they have not met the requirements to pursue studies in another field at a tertiary level. There has been an emphasis in the past, and it remains largely unchallenged, that a university education is superior to a college qualification (Makholwa, 2015). This can have an influence on the motivation of TVET students if they fall into that category of student who is disappointed that they are not working towards the achievement of a degree.

As pointed out in the Green Paper for Post-School Education and Training (DHET, 2012a, p. 22), this broad range poses a significant challenge to the lecturer as they are “teaching...very different cohorts of students in the same classroom”.

2.3.2 Vocational education and combined approaches to formal education

South Africa’s public TVET colleges “exist at the cross roads between compulsory education, higher education and the world of work” (Powell, 2012, p. 643). They provide a non-traditional route to higher education (Powell, 2012) and do not exclusively aim for students’ immediate employment. This is crucial to note, as the design of programmes and curricula needs to hold these aims in tension. Not only should students finish the NC(V) Engineering course as employable artisans, but they should also be ready to pursue higher education should they desire to do so (RSA, 2009). For the South African economy, this means that NC(V) Engineering graduates could be a source of artisans as well as future engineering professionals.

Papier, Needham and McBride (2012) report that there is similarly an “increasing international emergence of combined approaches to formal education and workplace based training” (p. 13) that mirrors what we see in TVET in South Africa. These approaches emphasise the responsibility of vocational training for providing both workplace preparation and the foundation of knowledge required to pursue higher education in that field. (Papier et al., 2012). As Papier et al. (2012) note, however, this type of approach is “easier said than done” (p. 13).

A recently released United Nations Educational, Scientific and Cultural Organisation [UNESCO] publication (UNESCO, 2015), emphasises that the “quickenning pace of technological and scientific development is making it increasingly difficult to forecast...associated skill needs” (p. 60). The competencies acquired by students need to be flexible and allow for “the adaptation of competencies to rapidly changing needs” (p. 60). As mentioned earlier, the students’ learning needs to be sufficiently powerful to allow for the adaptive use of their knowledge.

2.3.3 Pathways to the workplace and further training available to NC(V) graduates

Because of the combined approach taken in the NC(V), there are pathways open to NC(V) graduates both to the workplace and to further training in their field.

The NC(V) leads directly into the workplace for students who would like to work as artisans. For those that wish to pursue further studies to become Engineering Technicians, Certificated

Engineers, Engineering Technologists or Professional Engineers, there are pathways that are open to them that are dependent on their performance in their NC(V) subjects.

The following sections outline these pathways. First, the steps to becoming an artisan are described. Thereafter, the paths to further training and professional registration in other categories of engineering practice are outlined. It is important to note that students' mobility along these paths is largely dependent on their performance in Mathematics (ECSA, 2012).

2.3.3.1 Seven steps to trade certification as an artisan

It has already been mentioned that the HRDCSA (2016) indicates that career guidance needs to improve to increase the number of individuals enrolling in programmes that ultimately lead to artisanship. There are an additional 6 steps that make up the national model of the route to trade certification as an artisan. To find employment or practice as an artisan, one needs to possess a trade certificate. These are available for the trades listed in the South African Skills Development Amendment Act (RSA, 2012).

The seven steps to this certification are shown in Figure 2.1 below. These represent the result of a review of the previous trajectory, and an examination of international benchmarks for qualification as an artisan (Makholwa, 2015). For adults who have already been working in the appropriate workplace, it is possible that after the process of RPL is concluded, they can move directly to the trade test.

Figure 2.1 Seven steps to becoming an artisan

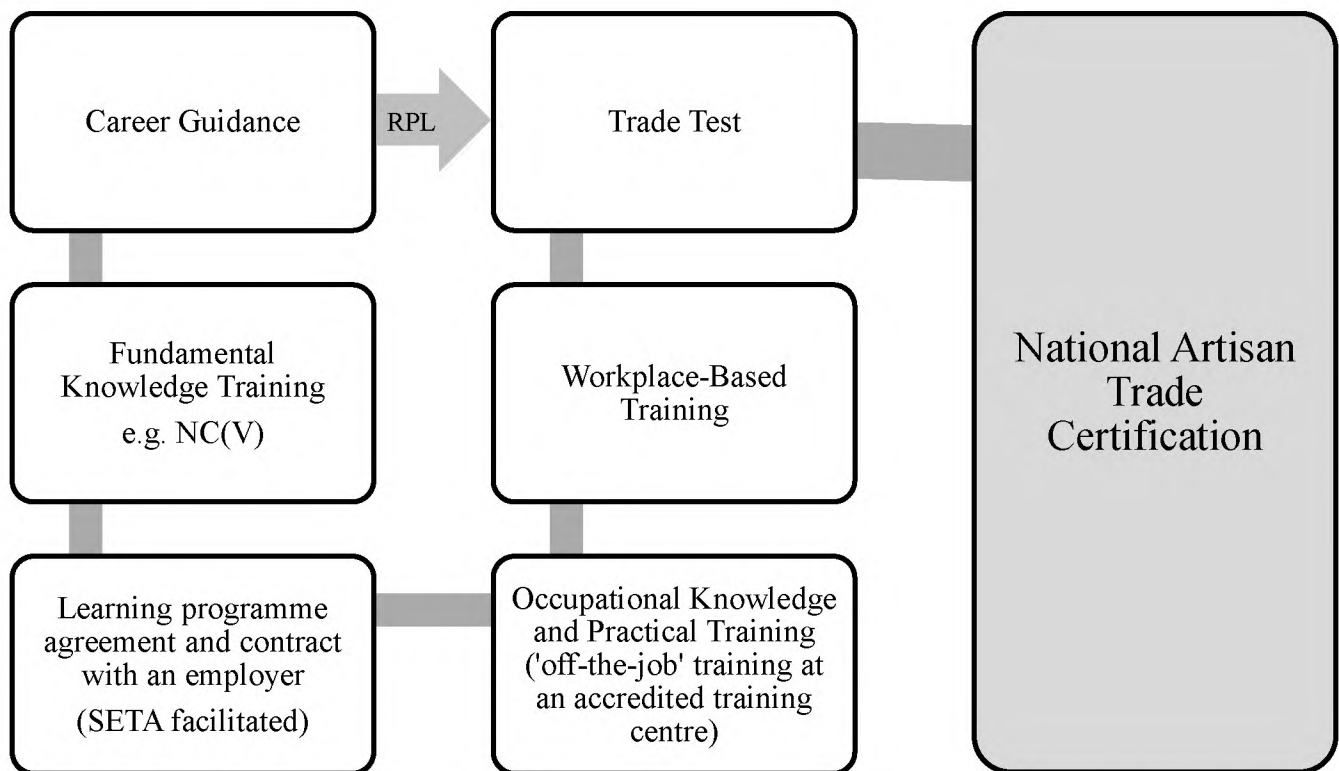

(HRDCSA, 2016)

A “structured learning programme of knowledge, practical and work experience” (RSA, 2012, p. 17) is central to the route to artisanship. Following appropriate career guidance, students enter a course which provides them with fundamental knowledge. This would include the NC(V), and would be specific to a field, e.g. Fitting and Turning, Welding or Automotive Repair and Design (which are the foci of this research).

As it is the first step in their training, students’ performance in the NC(V) largely determines whether it is possible for students to move on to subsequent steps. In January 2016, the DHET released the following statement to the press: “40% in Mathematics...is a requirement for artisan consideration” (DHET, 2016b, p. 1). This highlights the importance of performance in Mathematics.

After successful conclusion of fundamental knowledge training, students enter into an agreement with an employer who partners with the student to provide workplace-based training after occupational and practical training are completed at an accredited training centre. Through their promotion of artisanship during the Decade of the Artisan, the DHET aims to “relink...employers and workplaces to the TVET college system” (Kolver, 2014, p. 1), by

requiring that Sector Education Training Authorities [SETAs] become involved in facilitating these partnerships.

Overseeing all of this, and facilitating links between trainee artisans, accredited skills development providers, SETAs, and other stakeholders involved in training artisans, is the DHET's newly constituted National Artisan Development Support Centre [NADSC] (HRDCSA, 2016). These partnerships are crucial to enabling students to progress through these seven steps and for this to become an efficient system of producing artisans, from recruitment to employment.

2.3.3.2 Pathways to further study post-NC(V)

After obtaining their NC(V) Level 4 qualification, students can move on to study further in their field, provided they achieve the minimum requirements for admission, and provided the qualification is in the same field as the NC(V) the student has achieved. The general admission requirements for qualifications are listed below (RSA, 2009):

- Higher Certificate (Level 5): A NSC or a National Certificate (Vocational) in a field relevant to the specific Higher Certificate
- Diploma (Level 6): At least 50% for Mathematics, Life Orientation and the Language of Learning and Teaching [LoLT] of the institution; at least 60% for three further subjects
- Bachelor's Degree (Level 7/8): At least 60% for Mathematics, Life Orientation and the LoLT of the institution; at least 70% for four further subjects

While it seems implied by the admission requirements that sufficient achievement in NC(V) should permit access to Diploma and Bachelor Degree studies in engineering, ECSA (2012) is adamant that it is performance in NSC Mathematics, Physical Science and the LoLT of the institution that are to be considered for direct entry into engineering diploma and degree programmes (NQF Levels 7 and 8). This closes the possibility of moving directly into these professionally-oriented courses for NC(V) graduates, however, a vocationally-oriented pathway is open. These programmes focus more directly on workplace competencies. Should students wish to move from the vocationally-oriented path to study towards a qualification at NQF Levels 7 and 8, they need to acquire a Diploma in Engineering Technology (ECSA, 2016f).

The figure below provides an illustration of the pathway to further training that is open to NC(V) graduates.

Figure 2.2 Pathways to further training for NC(V) Engineering graduates

(ECSA, 2015a; 2015b; 2016b; 2016c; 2016d; 2016e; 2016f)

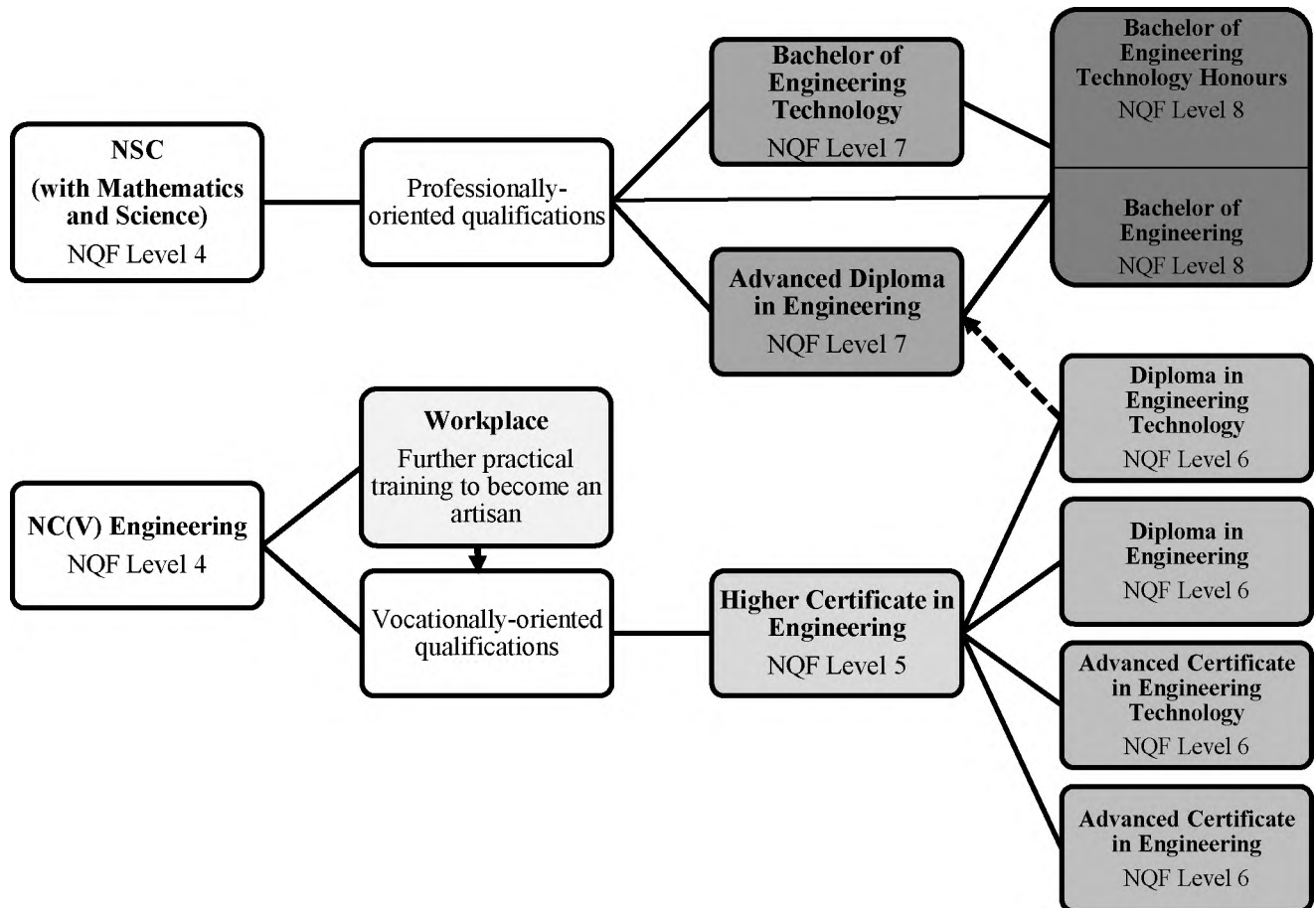

After achieving a Higher Certificate in their chosen engineering field (NQF Level 5), students can enrol for a one-year Advanced Certificate in Engineering or in Engineering Technology (NQF Level 6). Alternatively, depending on their performance in the Higher Certificate, students can gain entry to a vocationally-focused Diploma in Engineering or Engineering Technology, a three-year qualification at NQF Level 6. Having achieved a Diploma in Engineering Technology, it becomes possible to move into the professionally-oriented stream of qualifications to enrol in an Advanced Diploma in Engineering (indicated by the arrow on Figure 2.2). It is only the Diploma in Engineering Technology that allows access to the Advanced Diploma in Engineering.

2.3.3.3 Pathways to the workplace as a professionally registered engineer

Having achieved any of the qualifications shown in Figure 2.2, students can exit the training pathway to enter the engineering workplace. ECSA (2002, p. 3) lists the following as being core functions in the engineering workplace: “design, research and development, commissioning, project or construction management, *measurement* [emphasis added] and testing, planning, quality assurance, production, maintenance [and] management”.

As previously indicated, exiting this path with a NQF Level 4 NC(V) qualification allows further progression along the seven steps to becoming an artisan and ultimately, trade certification as an artisan. Exiting at any higher NQF Level requires registration with ECSA, as legislated in the Engineering Profession Act (RSA, 2000). Figure 2.3 illustrates the categories of registration available per NQF level, and provides an expansion of the process towards achievement of this registration.

Figure 2.3 Pathways to the engineering workplace per NQF exit level

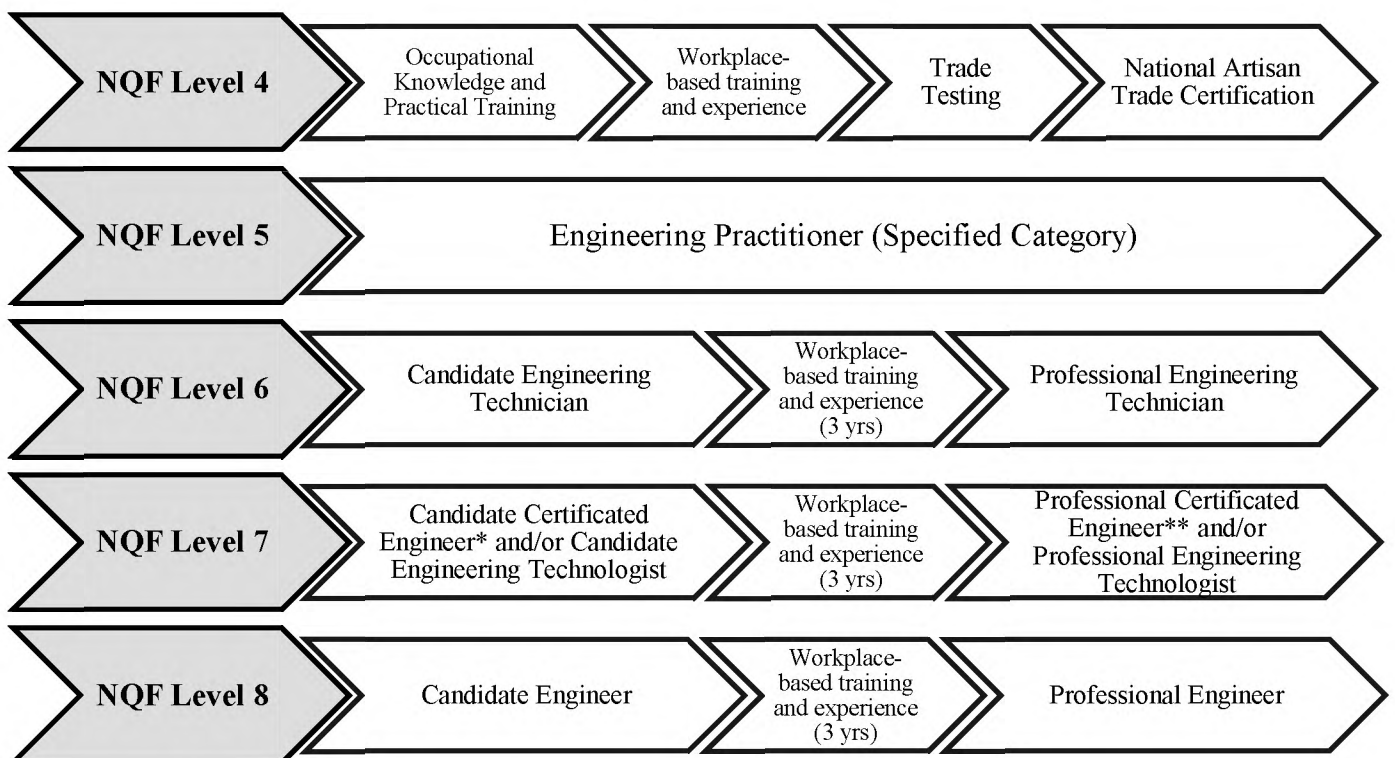

* graduates with a Diploma in Engineering (NQF level 6) are also eligible for registration as candidate certificated engineers

** candidates are required to write an examination to become a professional certificated engineer (ECSA, 2004, 2016a; HRDCSA, 2016)

The category of Engineering Practitioner “provides for the registration of persons who cannot register in the professional category, but who perform critically important work of an engineering nature” (RSA, 2000, p. 16). Trade certification does not exist for these jobs, although they can be classified as engineering roles. This includes, for example, lift technicians. It fulfils the legislative requirement for registration with ECSA, but does not provide a pathway to professional registration.

New graduates with qualifications at NQF Levels 6 – 8 move on to register as candidate professionals in a category specific to the level of their qualification. As is shown in figure 2.3, the Engineering Profession Act (RSA, 2000) specifies the following categories of registration:

- Engineering Technician
- Certificated Engineer
- Engineering Technologist
- Engineer

Following a minimum of 3 years of further workplace-based training and experience, candidates can begin the application process to become registered professionals. Core to these applications is the submission of an Engineering Report. Such reports are required to cover what are considered to be the engineering functions: “conceptualisation, design and analysis, specification, tendering and adjudication, manufacturing, project and construction management, commissioning, maintenance, *measurement* [emphasis added] and testing” (ECSA, 2014, p. 8).

2.3.4. The importance of mathematics at every level of engineering work

It is repeatedly noted that students’ performance in Mathematics enables their mobility into the workplace and along the NQF qualification pathway. In engineering, Mathematics acts as a gatekeeper to accessing training, and competence in Mathematics is necessary for successful performance of the work of an engineer.

2.4. SHIFTS IN APPROACHES TO TVET RESEARCH IN SOUTH AFRICA

Research concerns in the South African TVET sector have undergone several shifts in the past twenty years and the “current structures and ideologies both reflect our histories and reveal attempts to move beyond this” (Lotz-Sisitka & McKenna, 2015, p. 2). This section will trace the approaches that have been taken in researching the South African TVET context from 1994

to post-2009. Important shifts will be noted and this research will be contextualised according to these.

2.4.1 Distinct research periods

Powell (2013) provides an overview of research in this field and describes it as showing 3 relatively distinct periods:

- 1994 – 2003 Period of Reconstruction
- 2003 – 2009 Period of Early Critique
- 2009 – Deconstruction – A new movement

2.4.1.1 The Period of Reconstruction

During the Period of Reconstruction, which began with South Africa's first democratic elections, the TVET sector underwent major changes. The aim of research conducted during this time was to inform the design of legislation and the formation of colleges (Powell, 2013). The culmination of this was the merger of 152 technical colleges to form 50 FET colleges (later to be renamed TVET colleges) in 2002 (Powell & Lolwana, 2012). This transformation sought to shift student and staff demographics in terms of race and gender to become representative of the South African population (Powell & McGrath, 2014). Most of the research in this period was funded by the government and donors in partnership with the government and the aim of this research was to provide “‘hard’ data on which policy could be built” (Powell & Lolwana, 2012, p. 9). The research approach was predominantly applied and instrumental and the preferred methodologies quantitative (Powell, 2013).

2.4.1.2 The Period of Early Critique

By the Period of Early Critique, the policy and structural foundations were in place (Powell, 2013) and the focus of research turned to a critical engagement with policy. Researchers became concerned that the sector was failing in its stated outcomes (Powell, 2013). While the aim of research largely shifted in this period, it remained methodologically and paradigmatically similar to the Period of Reconstruction (Powell, 2013).

2.4.1.3 Shifting policy discourse

In 2009, there was further reorganisation in the sector as colleges became the responsibility of the newly formed DHET (Powell, 2013). This renewed debates about skills development and vocational education and shifted the policy discourse “toward an integrated post-school system that focuses on the needs of the poor” (p. 73). With the recent publication of the White Paper on Post-School Education and Training (DHET, 2013h) and the earlier Green Paper (DHET, 2012a), the policy discourse has now shifted towards a more integrated and expanded view of the post-school system. The system now not only seeks to meet the needs of industry but also aims to focus on the needs of students and communities and the alleviation of poverty: a far more student-centred approach (Powell & McGrath, 2014). In promoting an integrated post-school system, these documents also highlight the need for a combined approach to vocational education (DHET, 2013h).

Powell and McGrath (2014) indicate that until this point research in the TVET sector had been dominated by what they term to be ‘productivist’ accounts that “emphasise[d] economic growth and income generation as key development objectives” (p. 10). Thus, overly structural approaches and quantitative methodologies have been favoured and this has similarly been the dominant approach in international research in TVET (Powell, 2013).

2.4.2 Educational research in a time of measurement

In the past twenty years, educational research across the globe has entered a “time of measurement” (Sporre, 2015, p. 11). On a global scale, the last twenty years have seen the increased use of large-scale international studies that examine the educational outcomes of students across countries (Sporre, 2015). South Africa has participated in a number of these, including the Trends in Mathematics and Science Studies [TIMSS] (Mullis, Martin, Foy & Arora, 2012); Progress in International Reading Literacy Study [PIRLS] (Howie, van Staden, Tshele, Dowse & Zimmerman, 2012); Southern and Eastern African Consortium for Monitoring Educational Quality [SACMEQ] (Moloi & Chetty, 2010) and has also implemented the Annual National Assessments [ANA] to assess literacy and numeracy between Grades 1 and 9. Together with the reports on the results of the NSC examinations issued annually, there exists a large amount of easily available quantitative data about educational outcomes in South Africa.

While this information is valuable, Lotz-Sisitka and McKenna (2015) emphasise that what is left out when assessing educational quality by means of wide-scale benchmark testing indicators and systems level studies, is quality at the level of the classroom. With South African TVET research having undergone the shift in discourse away from a focus on “economic growth and income generation” (Powell & McGrath, 2014, p. 10), the productivist model, with its focus on “‘hard’ data” (Powell & Lolwana, 2012, p. 9) and its preference for quantitative methodologies (Powell, 2013), does not provide adequate information at the level of the classroom. It provides an “insufficient account of individual [students]” (Powell & McGrath, 2014, p. 12).

The research carried out to this point has been crucial to the building of this sector, and indeed, to constructing the policies that shifted this discourse, but there are several limitations. These approaches “tell us little about the recipients of [TVET]” (Powell, 2013, p. 74). TVET students are “not simply empty slates enrolling at colleges in the hope of acquiring employability skills” (Powell & McGrath, 2014, p. 12) and current approaches to TVET research in South Africa, as well as internationally, “have largely ignored the voices and experiences of students” (p. 9).

To date, only three South African studies have examined TVET from the perspective of the student: Needham and Papier’s (2012) research about student perceptions of vocational education, Powell’s (2012) small-scale study about the impact of the colleges on the lives of students and Powell and McGrath’s (2014) paper encouraging the use of a capability approach in considering TVET students. No qualitative studies in SA have yet considered what students bring to the course in terms of prior knowledge and experience nor have they examined what is happening in the classrooms themselves (see Papier et al., 2012).

The situation is similar in mathematics education in the TVET sector. Two studies, both commissioned by quality assurance body Umalusi, have explored the NC(V) curriculum. These comparative studies mapped the NC(V) mathematics curriculum onto the NSC mathematics curriculum (Houston, Booyse & Burroughs, 2010), and the previous national curricula for vocational engineering (Matshoba & Burroughs, 2013). There is, however, no research yet that “speak[s] to the enactment of the curriculum and to college and classroom practice” (Papier et al, 2012, p. 18).

2.4.3 Taking a fresh approach to TVET research

Papier et al. (2012), in concluding their overview of contemporary issues in TVET colleges, suggest a research agenda which includes a call for “fine grained qualitative studies” (p. 23) that can contribute to building knowledge of the students. Despite the shift in policy discourse both nationally and internationally, however, most new projects commissioned in the sector remain largely quantitative and focused on the level of management and the potential contribution TVET education can make to the economy (Powell, 2013). The International Centre for Technical and Vocational Education and Training [UNEVOC] (2014) similarly state that TVET research globally has too often focused on the systems level, leaving teaching and learning at the student and classroom level under-researched.

The interpretivist approach to analysis in this study is important to note. In the Period of Reconstruction and the Period of Early Critique interpretivist approaches were avoided as they were considered to emphasise “‘different voices’ and ‘different perspectives’, which went against the spirit of political integration and the need for consensual transformation” (Powell, 2013, p. 63) in the sector. With the limitations of the orthodox approach to TVET research in South Africa being increasingly recognised (Powell and McGrath, 2014) it is time to consider a fresh approach.

2.5 WHAT DO WE KNOW ABOUT THE TVET SECTOR?

The ongoing focus on large-scale, quantitative research in education means that what we do know in the South African TVET sector remains quantitatively biased. We know that despite “extensive investment of financial and human resources into building a new identity for TVET colleges” (Papier, 2009, p. 44) results have not yet met expectations. We also have extensive knowledge of staff demographics, student demographics, pass rates, certification rates, enrolment figures and other large-scale quantitative statistics. There is, however, a paucity of research that enlightens us as to the mechanisms underlying these statistics.

2.5.1 Performance in Mathematics

Over the period 2007-2009, the mean throughput rate for the NC(V) Engineering programmes was 24% for Level 4 (Cosser, Kraak & Winnaar, 2011). Cosser et al. (2011) also point out that if attrition rates due to failure in Levels 2 and 3 are incorporated in these calculations, the

percentage of students who enrolled for Level 2 in 2007 and completed Level 4 in 2009 is 4.4%.

Similarly, results in NC(V) mathematics are disappointing. The table below shows the percentage of students passing mathematics for the period 2011 – 2014. While there is an increase evident in 2012, the upward trend for Level 4 is not maintained in 2014, with this pass rate dropping by 8% between 2012 and 2014. This is problematic in a system emphasising a combined approach, as students must perform well in mathematics to articulate to university studies in engineering (ECSA, 2012). Paterson (2016) adds that there is not only a pattern of failure in Mathematics, but a pattern of repeated failure.

Table 2.2 Percentage of students passing NC(V) mathematics from 2011 - 2014

	2011	2012	2013	2014
Mathematics Level 2	22%	<u>44%</u>	45%	47.2%
Mathematics Level 3	16%	36%	<u>39%</u>	46.4%
Mathematics Level 4	16%	43%	41%	<u>35%</u>

Statistics from DHET (2013c, 2014, 2015a)

In addition to the disappointing mathematics results, the NC(V) certification rate at Level 4 for the end of the 2014 academic year was 34.4%, substantially lower than the targeted 57% (DHET, 2015a). The 2014 Level 4 class (pass rate bold and underlined in Table 2.2) have a 6% cohort progression rate if attrition rates due to failure from Level 2 to Level 4 are taken into consideration for this group. The DHET (2015a) has attributed this primarily to the compounded effect of poor performance in Mathematics and Mathematical Literacy across NC(V) levels. Other factors identified by the DHET (2015a) as influencing the performance of students include “poor class attendance and disruptions caused by strikes” (p. 73); “inappropriate or lack of pedagogical training [of lecturers]” (p. 73); “unsuitable teaching and learning...practices” (p. 73); and “lack of systematic screening of teaching and learning materials” (p. 73).

In 2015, the targeted certification rate for NC(V) Level 4 was 59% (DHET, 2016a). The actual achievement was significantly lower, at 23.3%. The comment made by the DHET in this regard was that “[r]apid expansion of the system has a negative impact on the quality of provision and

the student strikes also disrupted teaching and learning” (p. 109). No pass rate for Mathematics is reported on in this Annual Report as had been the case in all previous such publications.

Considering these results, we must acknowledge that current practices are ineffective, and yet what we do not learn from any of these statistics is the detailed picture of what is happening in the NC(V) Level 2 Mathematics classroom.

2.5.2 Developing the skills of Mathematics lecturers

As highlighted earlier, the HRDCSA (2016) explains that poor quality teaching in TVET colleges is one issue that needs to be addressed. Between 2011 and 2014, a Colleges Improvement Project [CIP] was implemented by the Joint Education Trust [JET] in the Eastern Cape. The core focus of the project was on promoting quality teaching and building competencies of lecturers and students (Paterson, 2016). A strategic choice was made to concentrate particularly on those subjects where the biggest challenges were being experienced (Marock, Hazell & Akhoobai., 2016). Mathematics lecturers’ competence was identified as requiring particularly urgent attention. While stakeholder feedback after the project was generally positive, it was emphasised that there was still a long way to go in addressing challenges related to lecturer competence in teaching Mathematics despite the JET interventions.

The Mathematics classroom is, of course, attended by students as well the lecturer. Research that balances a focus on both students and teaching and learning techniques has the potential to propose solutions at the classroom level that may enhance teaching and learning. It is the aim of this research to provide such a balance. The research questions first guide attention to students’ existing conceptualisations of measurement, and having examined those, move to interrogate where the break occurs between what students need to have as stable conceptualisations, but rather possess as emerging conceptualisations.

2.5.3 Asking new questions

As Powell (2013) emphasises, “it is time to ask new questions and, perhaps, to ask them in different ways” (p. 75). In exploring the students’ prior conceptual understandings of measurement as they enter the course, this research contributes such a new question. Similarly, in its interpretivist approach and fine-grained qualitative analysis it offers a different way of

looking at the vocational student that will offer a new perspective on vocational education and training research both nationally and globally.

2.6 PRIOR SCHOOLING IN CONTEXT

In addition to entering the course with a variety of levels of prior schooling, students enter the course from a variety of schools. While measurement conceptualisation begins in early childhood (Feikes, Schwingendorf & Gregg, 2009), the formalisation of these conceptualisations begins from Grade R and continues throughout the learners' school careers (Department of Basic Education [DBE], 2011e). It therefore becomes relevant to note the school context in which these concepts have been encountered. It is not the aim to dwell on a negative picture but as this research explores students' existing measurement conceptualisations, it is important to have a notion of where these students have come from in terms of their prior school experiences.

Paterson (2016) reports that findings from the CIP revealed that the level of preparedness of new students varied according to their academic background and the catchment area of the college. For this reason, the quintile classification of South African schools will be outlined, with specific reference to the Eastern Cape context. This will be followed by a discussion of the comparability of grade passes from different schools to further contextualise the indicators of levels of prior schooling.

2.6.1 The quintile system in South Africa

In South Africa, schools are grouped into quintiles according to the average relative income of the community in which the school is situated (Villette, 2016), as well as infrastructure and levels of unemployment and illiteracy in the community (Collingridge, 2013). This is a "poverty ranking" (Grant, 2013, p. 1) that primarily serves to determine how financial resources are allocated to schools by the government. Quintile 1 is considered 'most poor' and quintile 5 considered 'least poor'. Schools in quintiles 1 to 3 are not permitted to charge school fees and are wholly reliant on government subsidies allocated per learner per year. Schools in quintiles 4 and 5 are allocated a much smaller subsidy per learner and supplement this by charging school fees (Grant, 2013).

The amount allocated is intended for use in payment of municipal services and purchasing of stationery and learning support materials (e.g. textbooks), equipment (e.g. photocopiers) as

well as maintenance and repairs (Grant, 2013). In 2013, however, several schools in quintiles 1 to 3 were found to be illegally charging fees as they were unable to function adequately by relying only on government funding (Phakathi, 2013). These schools reported being unable to buy necessities as basic as chalk (Phakathi, 2013). It cannot be denied that the quality of learning experiences is compromised in these schools due to limited, if not a complete lack of, resources.

In the balance of number of schools per quintile, all provinces are not equal. The distribution of schools per province and quintile, provided in Figure 2.4, reveals clear differences. More than 95% of schools in the Eastern Cape [EC], the province in which this research was conducted, fall into quintiles 1 – 3, whereas in provinces such as Gauteng [GT] and the Western Cape [WC] the percentage of schools in quintiles 1 – 3 is approximately 50%.

Figure 2.4 Distribution of schools by province and quintile

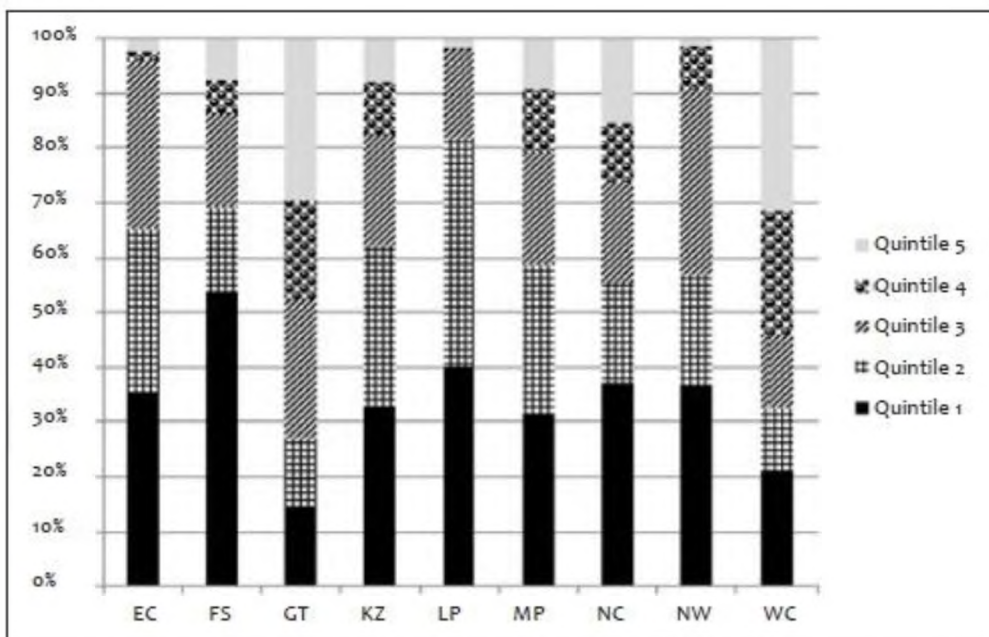

EC [Eastern Cape]; FS [Free State]; GT [Gauteng]; KZ [KwaZulu Natal]; LP [Limpopo]; MP [Mpumalanga];
 NC [Northern Cape]; NW [North West]; WC [Western Cape]
 from van Wyk, 2015, p. 150

Nationally, 65% of children are in ‘no-fee’ schools, and this number is increasing (Villette, 2016). In the Eastern Cape, this percentage is as high as 71.6% (Grant, 2013).

According to the quintile classification of the schools the participants in this research attended (DHET, 2015e; 2015f), 95% attended schools in quintiles 1 – 3. What is implied in this figure

is that for 95% of the participants, their encounter of measurement in the classroom context will most likely have been compromised by a lack of physical resources in the classroom, among other disadvantaging factors.

2.6.2 All grade passes are not equal

The only examinations that are “nationally standardised and externally evaluated” (Spaull, 2012, p. 12) in South Africa are the Grade 12 NSC examinations. For this reason, Spaull (2012) argues that any grade pass below Grade 12 cannot be taken as a true indicator of learning. He further explains that there is a “high dropout rate in grade 11 and 12 largely because students are not acquiring the foundational skills they should be in earlier grades” (p. 1). This creates challenges for those students as they move through to later grades as well as into further learning opportunities at TVET colleges.

The following figure illustrates the average Grade 8 level results for 24 middle income countries. It shows the vast difference in mathematics performance of South African Grade 9 learners attending schools in quintiles 1 to 3 when compared to learners attending schools in quintiles 4 and 5.

Figure 2.5 Average grade 8 mathematics test scores for middle-income countries participating in TIMSS 2011 (+/- 95% confidence intervals around the mean)

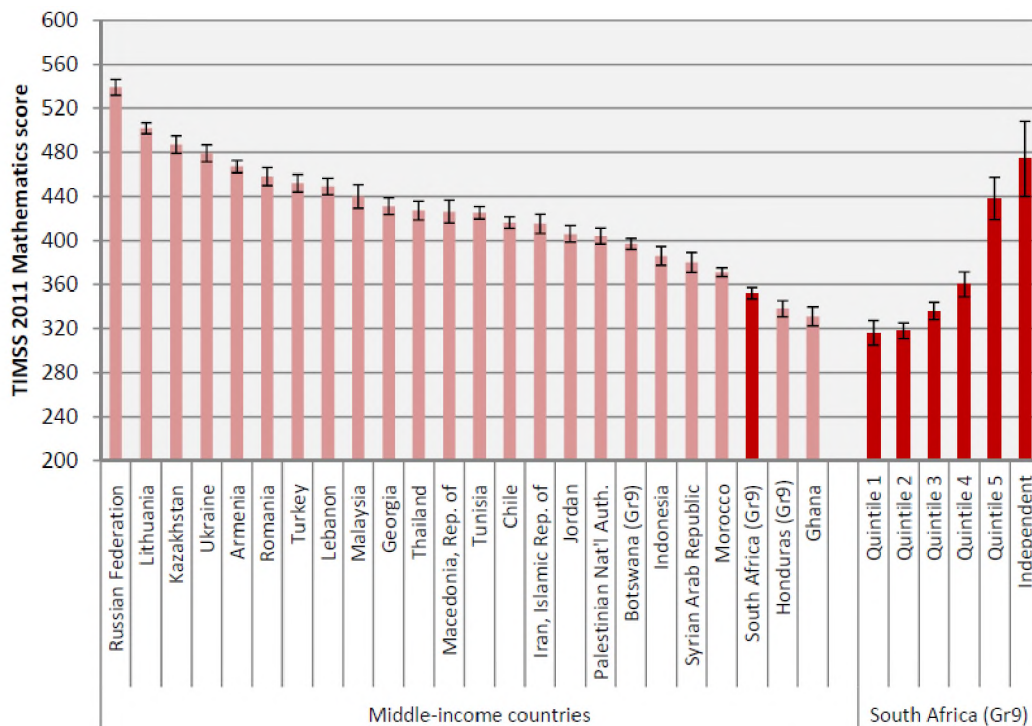

From Spaull (2013, p. 18)

South Africa was one of only three countries whose Grade 9 learners completed this Grade 8 level assessment. Despite the fact that the learners were a grade level higher than the assessment was designed for, South Africa's score placed it in the bottom three countries. South African quintile 1 and 2 schools performed the poorest in mathematics when compared to all middle-income countries assessed (Mullis et al., 2012). Quintile 5 school results were more than 120 points higher than quintiles 1 and 2 results, which would place these schools tenth of the twenty-four countries. This difference extends to 140 points when comparing these schools to independent schools, which would place independent South African schools at 5th out of these twenty-four countries.

As Spaul (2013) further explains, "the average quintile one and two Grade 9 pupil in South Africa is three years' worth of learning behind the average quintile 5 pupil in mathematics" (p. 18). Therefore, where students have not achieved their NSC, it needs to be noted that one student's achievement of a particular grade level may not be comparable to another. In fact, if Spaul (2013) is accurate, for some students their true learning is three years behind the grade level they attained before entering the NC(V).

2.6.3 Acknowledging prior knowledge

While the diversity of students entering the NC(V) at Level 2 makes it difficult to establish "level and prior experience of learning" (Haggis, 2006, p. 522), it is more productive to acknowledge that these individuals do arrive with a great diversity of experience that could be capitalised on (McAuliffe, Hargreaves, Winter & Chadwick, 2008). It is this which drives the current research, that attempts to establish the nature of the measurement conceptualisations NC(V) students enter the course with.

The questions we ask need to change to "what are the features of the curriculum, or of processes of interaction around the curriculum, which are preventing some students from being able to access the subject?" (Haggis, 2006, p. 526). However, while it needs to be recognised that these students possess prior knowledge, we have yet to determine how such knowledge is structured.

When seeking to explore adult students' prior knowledge, it is necessary to gather background data that includes the highest school grade passed. This does give some indication of their prior experience in learning measurement. As has been mentioned, it also needs to be noted that this is not necessarily a true reflection (Spaul, 2012).

For the sample of students participating in this research, the fact that 95% attended schools in quintiles 1 – 3 implies that Spaul's (2013) claim that the average learner in lower quintile schools could be as much as three years behind in their learning should be kept in mind.

2.7 MEASUREMENT LEARNING ACROSS CURRICULA

Measurement is “a necessary foundation for much of mathematics and...many of the real-world applications of mathematics are measurement-related” (Preston & Thompson, 2004, p. 437). It is also an area of mathematics that many students find particularly challenging (Preston & Thompson, 2004). Large scale international studies bear this out, with the international average for measurement being the second lowest of the mathematical strands assessed at the 4th Grade level in the most recent TIMSS (Mullis et al., 2012). The international average for this strand was below 50% (Mullis et al, 2012, p. 460).

This challenge was also apparent when examining the 2014 ANA results for the Intermediate Phase (Grades 4 – 6) and Grade 9 (DBE, 2014a). For all grades assessed, components of performance on measurement tasks were listed as one of the ‘areas of weakness’ and measurement was the content area in which learners performed the poorest (DBE, 2014a). The average achieved for this content area per grade was: 13% (Grade 4); 31% (Grade 5); 32% (Grade 6) and 8,6% (Grade 9).

2.7.1 Measurement as crucial to engineering practice

The mathematics education context of this research is measurement learning. Its importance lies in the fact that achievement in measurement is crucial to engineering practice, and as such is listed by ECSA (2014) as one of the engineering functions in which candidates need to demonstrate competency to be considered for promotion to professional status. As previously mentioned, these engineering functions include: “conceptualisation, design and analysis, specification, tendering and adjudication, manufacturing, project and construction management, commissioning, maintenance, *measurement* [emphasis added] and testing” (p. 8). In addition, it appears as a specifically named component of the definition of a trade: “*Measure* [emphasis added] and do fault finding on processing, manufacturing, production and/or technical machinery and equipment to apply corrective or repair actions” (RSA, 2012, p. 17).

In NC(V) Engineering, measurement is included in the Mathematics curriculum, as well as being specified in learning outcomes of the specialised engineering subjects from Levels 2 to 4. Examples include:

Automotive Repair and Maintenance, Level 4: “Use appropriate measuring instruments to measure parts according to manufacturer’s procedures and record the actual measurements” (DHET, 2015b, p. 8)

Fitting and Turning, Level 4: “Measure and test replacement parts and evaluate performance” (DHET, 2015c, p. 6)

Welding, Level 4: “Establish welding parameters and conform to requirements” (DHET, 2015d, p. 8)

Applied Engineering Technology, Level 4: “Consider the mass of matter with reference to its direct relationship to friction and the force required for motion” (DHET, 2007, p. 10)

2.7.2 Expected trajectory of measurement learning

Students’ formal introduction to measurement starts in Grade R (DBE, 2011e), but for the purposes of this discussion, measurement learning will be mapped from the Intermediate Phase [IP] (Grades 4 – 6) through the Senior Phase [SP] (Grades 7 – 9) and on to the Further Education and Training [FET] band (Grades 10 – 12). As the focus of the research is on prior knowledge, this mapping serves to illustrate the expected prior learning that students would have been exposed to.

Specifically, measurement of length, area, volume and speed are considered as they are the concepts around which the tasks in this research are based. Flow rate, another focus in this research, does not feature in any of these curricula, hence its absence in these maps. Five Appendices (E, F, G, H and I) provide the curriculum maps referred to in this section.

Where reference is made to ‘measuring’, it is the practical use of equipment to measure physical quantities that is referred to. Where reference is made to ‘calculation’, the use of formulae and definitions to calculate a measurement, in the absence of the object to which the measurement applies, is referred to.

2.7.2.1 Measurement learning in the Intermediate and Senior Phases

Appendix E provides a mapping of measurement learning from Grades 4 to 9, as well as a comparison between these and the ABET Level 4 qualification. This qualification is at NQF Level 1 and is therefore equivalent to Grade 9.

While measurement, per se, is the content area carrying the smallest weighting for all grades in the IP and SP (DBE, 2011b; 2011c), its importance cannot be overemphasised because of its critical relationship with the interrelated concepts of fractions, decimals and percentages which abound in other sections of the curriculum (see DBE, 2011b; 2011c). These concepts are internationally and locally acknowledged to be key areas of difficulty for learners, as they require strong number sense as well as a connected understanding of these concepts (Mullis et al., 2012; DBE, 2014a). Measurement contexts provide particularly fertile ground for developing such connected understanding.

In the IP, measurement problems provide an important real-world context through which learners work with fractions and decimals (DBE, 2011b). Proficiency in working with fractions, decimals and percentages in IP can be supportive of measurement learning, but similarly, measurement activities and problem-solving can act as a context in which work with fractions and decimals can improve (Lamon, 2012).

Despite this, over the entire IP only 18 weeks, out of a possible 130, are devoted to measurement (DBE, 2011b). This is understandable due to the weighting of the content, but it is clear from examining the results of country-wide assessments (e.g. DBE, 2014a) that intervention is required to improve learners' performance. This intervention needs to be time efficient and sufficiently powerful and thus requires careful research into possible means of doing so.

In Grades R to 3, the Foundation Phase [FP], the learners' concept of measurement is developed as they work with different physical objects (DBE, 2011e). Physical measurement remains central in IP, but begins to blend with the more symbolic use of formulae. It is emphasised in the curriculum documents that no work with general rules or formulae should be done in Grades 4 and 5 (DBE, 2011b). In Grade 6 learners begin to encounter the use of formulae to calculate perimeter, area, surface area and volume (DBE, 2011b) as they investigate the relationships between these measurements (see Appendix E).

By Grade 7, the beginning of SP, learners are almost exclusively using formulae to calculate perimeter, area, surface area and volume (DBE, 2011c). It is at this point that there is a risk of focussing on the procedure of using formulae without maintaining the link to the real-world context to which these problems refer. Physical measurement of perimeter, area, surface area and volume is replaced with the requirement that students use appropriate formulae to calculate these quantities (see Appendix F). The range of shapes and objects increases from grade to grade. In Grade 7 it is only the area of squares, rectangles and triangles that are calculated. By Grade 9 students are also required to work with polygons and circles.

There is a clear shift in focus from IP to SP. In IP, physical measurement of quantities is central, whereas, from the very beginning of SP the focus shifts to the symbolic use of formulae.

2.7.2.2 Measurement learning in ABET Level 4

Students enrolled in ABET Level 4 select to either study Mathematical Literacy or Mathematics and Mathematical Sciences [MMS]. In Mathematical Literacy, measurement outcomes are weighted at 44% of the total credits and of the allocation of marks in the final summative assessment (DHET, 2013a); in MMS, these outcomes are weighted as 14% of the total credits and the total marks for their final summative assessment (DHET, 2013b). ABET Level 4 students can move on to TVET colleges to pursue an NC(V) qualification as they hold a qualification of the same NQF level as a Grade 9 learner.

While Mathematical Literacy maintains a dual focus on calculation using formulae as well as the use of measuring instruments to measure quantities, MMS focuses solely on the calculation of quantities using formulae. These outcomes are summarised in Appendix E.

2.7.2.3 Measurement learning in the FET Band

Grade 9 marks the end of compulsory schooling in South Africa, and is the point at which learners can elect to move to a TVET college to study towards an NC(V) qualification. Learners who choose to remain in school move into the FET band and work towards the achievement of the NSC. These learners are afforded the choice between the subjects Mathematics and Mathematical Literacy. Appendix G provides a broad comparison of measurement learning for these two subjects.

In Mathematics, measurement does not continue through the whole phase as a distinct topic. In Grade 10, spheres, pyramids and cones are added to the range of objects from Grade 9 for which volume and surface area are to be calculated. This is done by the application of given formulae (DBE, 2011d). In Grades 11 and 12, measurement knowledge is applied in the context of trigonometry, analytical geometry, Euclidean geometry and calculus (see Appendix G).

In Mathematical Literacy, measurement is an important “application topic” (DHET, 2011a, p. 12) which is weighted at 20% (+1.5%) in terms of the allocation of teaching hours and allocation of marks in the final summative assessment. Appendix H provides a more detailed breakdown of the skills that are examined in this research: conversions, length/distance, area, perimeter and volume.

The curriculum makes a distinction between “basic topics” (DHET, 2011a, p. 12), comprising “elementary mathematical content and skills that learners have already been exposed to in Grade 9” (p. 13), which is revised during the application of these skills in the topics Finance, Measurement, Representations of the Physical World, Data Handling and Probability. Each year it is the difficulty of the calculations that increases, and the type of context in which they are applied that changes (see Appendices G and H).

2.7.2.4 Technical Mathematics

In technical high schools, students are offered Technical Mathematics for Grades 10 to 12. The aim of this subject is to “apply the science of mathematics to the technical field where the emphasis is on *application* [emphasis in original] and not on abstract ideas” (DBE, 2014b, p. 12) as well as to “provide learners at technical schools an alternative and value-adding substitute for Mathematical Literacy” (p. 10).

An outline of the measurement outcomes in this subject, alongside those for Grades 10 – 12 Mathematics and Mathematical Literacy, is provided in Appendix G. Unlike FET Mathematics, measurement appears as a distinct topic from Grade 10 to 12.

2.7.3 Measurement learning in NC(V) Level 2 Engineering programmes

Mathematics is a compulsory subject for students in any of the NC(V) engineering programmes. In Level 2, measurement appears as a distinct topic, with two main subject outcomes: *measuring* physical quantities and *calculating* physical quantities. Students are

required to make use of rulers and protractors in *measuring* physical quantities. The range of shapes and objects for which quantities are to be *calculated* adds parallelograms, trapeziums, hexagons and hexagonal prism to the range required in Grade 9 (DBE, 2011c; DHET, 2011). In addition, it is specified that students should be able to use Système International [SI] units appropriately.

The students participating in this study had an additional compulsory subject: Engineering Technology (DHET, 2012b). This subject includes two topics specifically addressing measurement, the first addressing the practical use of precision measuring equipment, and the second concerning the use of SI units.

The emphasis in Engineering Technology is on physical measurement of quantities rather than their calculation as is the case in Mathematics. Students are taught to use engineering precision equipment - both generic and specific to their field of study. The application of these skills includes deciding on the correct precision measuring instrument for a task, using marking off equipment, and producing accurate drawings in two-dimensional views (DHET, 2012b).

The depth of knowledge of SI units is also greater. The subject outcomes cover identification of basic units and defining the physical quantities they measure (DHET, 2012b). In addition, students perform conversions between units as well as derive new units based on relationships between the SI units and the quantities they represent.

2.7.4 Summary of measurement foci per curriculum

The measurement focus of each curriculum can be classified according to its relative emphasis on physical measurement, using measuring instruments, or calculation of measurements, in the absence of the object to which the measurement applies, using definitions and formulae. Table 2.3 provides a summary of these foci:

Table 2.3 Summary of measurement foci per curriculum

Grade 9	The use of physical measurement in earlier grades progresses to exclusive calculation using formulae by the end of Grade 9
ABET Level 4 Mathematical Literacy	Dual focus on physical measurement and calculation using formulae
ABET Level 4 Mathematics and Mathematical Sciences	Exclusive focus on calculation using formulae
NSC Mathematics	Exclusive focus on calculation using formulae
NSC Mathematical Literacy	Dual focus on physical measurement and calculation using formulae
NSC Technical Mathematics	Exclusive focus on calculation using formulae
NC(V) Mathematical Literacy	Dual focus on physical measurement and calculation using formulae
NC(V) Mathematics	Exclusive focus on calculation using formulae
NC(V) Level 2 Engineering Technology	Exclusive focus on physical measurement using precision measuring equipment

Certain subjects focus exclusively on one, as is the case with NC(V) Engineering Technology's exclusive focus on physical measurement, and NC(V) Mathematics' exclusive focus on calculation using formulae. Mathematical Literacy (ABET Level 4, NSC and NC(V)) is the only subject to maintain a dual focus on physical measurement and calculation using formulae.

2.8 SUMMARY

This chapter has provided a detailed description of the broad educational context in which this research is situated as well as a detailed outline of the positioning of the NC(V) qualification regarding the NQF and the workplace. Furthermore, a mapping of measurement learning across South African curricula was explicated as a means of placing the measurement learning in the NC(V) programme within the context of what students should have been exposed to during their prior schooling.

The rationale for the positioning of this research in this specific context, as well as the knowledge that it aims to contribute, was emphasised throughout.

CHAPTER 3

THEORETICAL FRAMEWORK

3.1 INTRODUCTION

The focus of this research is on the prior knowledge of measurement that NC(V) Engineering students hold as they begin their studies. Insight into students' existing measurement conceptualisations, as evident in their engagement in mediated measurement tasks, is sought. These conceptualisations of measurement are the result of prior learning and form the 'prior knowledge' that this research aims to reveal. The research seeks to establish what this prior knowledge is, as well as its genesis and how it might be built on. Both Piaget and Vygotsky offer theories that are useful when considering the development of measurement conceptualisations, and both regard prior knowledge to be important in this regard. For this reason, their theories form a guiding framework to this research, although in slightly differing ways.

Both theorists contend that "the learner is not a passive recipient of knowledge but that knowledge is constructed by the learner" (Rowlands & Carson, 2001, p. 1) as well as viewing this knowledge as actively constructed in response to social and physical interactions. However, Piaget and Vygotsky's perspectives on the development of thinking in concepts differ in their emphases. While Piaget (1964) considered cognitive development to be "a spontaneous process tied to embryogenesis" (p. 20), and that maturity of mental functions is necessary for learning to take place, Vygotsky (1978) considered learning and development to be inextricably linked and words and the social milieu to be the drivers of the development of conceptual thinking.

It is important to be aware of these differences, however, this research does not concern itself with Piaget and Vygotsky's global orientations to teaching and learning. Rather, it draws on the psychological concepts developed by each of them in order to construct an appropriate conceptual framework for this particular research focus.

Piaget's theory, and the neo-Piagetian work of David Tall, provide a particularly useful analytical framework for understanding mathematical concept development. This literature review opens with an outline of their theories which is followed by a discussion of mathematical understanding in general, and measurement in particular.

Vygotsky's work finds its application in the methodology of this research. His theory regarding the development of higher mental functions, including his notions of mediation and the zone of proximal development [ZPD], informed the design of the means of assessing measurement conceptualisation: dynamically assessed task-based interviews. The second part of the literature review, therefore, provides an outline of his developmental theory, taking care to highlight where he emphasises the importance of prior knowledge and how it speaks to measurement conceptualisation.

The outline of Vygotsky's work is followed by a more in-depth discussion of dynamic assessment. The task-based interviews were designed to dynamically assess the current measurement conceptualisations of students, based on their engagement with mediated measurement tasks. This approach allows an interviewer insight into the existing measurement conceptualisation of the student, but in addition, the task is mediated such that it becomes a learning opportunity. Mediation and dynamic assessment will be further explained in that part of the chapter.

Prior to closing the chapter, there is a section in which the contributions of Piaget and Vygotsky are again discussed. Having established that both theories have been used in the research design, it is necessary to make explicit the possible pitfalls in doing so, and to provide a full explanation of the way in which this research avoids these incompatibilities.

The chapter closes with a synthesis of the theories reviewed and an explanation of the resulting framework of mediated measurement interaction that provides structure to this research.

3.2 PIAGET AND FUNDAMENTAL THINKING ABOUT MEASUREMENT

Piaget (1964; 1972) explains that the development of mental functions occurs slowly from birth to the ages 12 – 15 through four stages: sensorimotor; preoperational; concrete operational and formal operational. He argued that these stages are “extremely regular and comparable to the stages of embryogenesis” (Piaget, 1964, p. 20), differing only in their speed of development depending on the individual and their social environment. While he emphasises “endogenous factors of construction” (Piaget, 1972, p. 44), he acknowledges the influence of the physical and social environment on the individual's development.

His theory provides a useful structure for understanding the development of mathematical conceptualisations. In its focus on operations on objects and interaction with the physical

world, it provides a particularly relevant perspective when considering the measurement of attributes of objects as well as relational measurements. In addition, his insistence that an understanding of the prior knowledge that a child brings to a classroom is important, resonates with the goals of this research.

What follows is an explication of Piaget's stage theory, with reference to its utility in understanding the conceptualisation of measurement.

3.2.1 Piaget's four stages of development

Piaget's (1964) theory of the development is centred on the notion of an "operation" (p. 20). He contends that one needs to act on an object to come to a knowledge of it, and that one comes to an understanding of how the object is constructed by modifying and transforming it and arriving at an understanding of that transformation process. Each stage in this development sequence is reliant on the achievement of the previous stage. What is achieved in one stage becomes the prior knowledge and conceptualisation on which the next stage is built.

He explains that "an operation is thus the essence of knowledge; it is an interiorised action which modifies the object of knowledge" (p. 20). This transformation is also necessarily reversible, for example, adding and subtracting or pouring liquid from one glass into another. Piaget (1964) makes mention of measurement as one type of operation on an object that allows the individual to "get at" (p. 20) the structures of the object of operation.

Conservation of quantity, achieved in the preoperational stage, is an essential precursor to being able to measure attributes of objects (Feikes, Schwingendorf & Gregg, 2008). Furthermore, if conservation is absent, then transitivity cannot yet be achieved (Piaget, 1970). Transitivity refers to the ability to order quantities according to their measure (Piaget, 1970), for example, understanding that if $A < B$ and $B < C$, then $A < C$. As with conservation, this is similarly a necessary precursor to the ability to measure (Piaget, 1970).

With the logic of reversibility of operations, certain stable structures begin to form, including the concept of measurement of lines and surfaces (Piaget, 1972). Reasoning remains closely linked to concrete objects but can be classified as operational (Piaget, 1972). At this point, the learner is as yet unable to reason about measurement if the concrete object that holds the relevant measurement attribute is not present.

Once able to use “hypothetic-deductive operations [of] propositional logic” (Piaget, 1964, p.21) the individual is considered to have reached the formal operational stage. At this stage in their measurement learning, the learner will have the prior knowledge and requisite conceptualisation to begin to apply formulae to calculate measurements, and to learn to do so in the absence of the concrete object to which the measurement refers.

3.2.2 Piaget and learning

Piaget (1964) claims that “[l]earning is subordinated to development and not vice-versa” (p. 26). He recognises that this is an idea that is contested by researchers who claim to have had success in teaching operational structures, but queries whether this learning endures. He explains that when a structure develops as the child experiences their physical world and progresses through the four developmental stages naturally, it will last throughout the child’s life (Piaget, 1964).

There are “continuing structuring processes in the child’s developing mental activity” (Piaget, 1962, p. 6), which Piaget refers to as spontaneous concepts. He distinguishes them from non-spontaneous, or learned, concepts, which are acquired in formal education. Rather than viewing the spontaneous concepts as being an obstacle to overcome in formal schooling, Piaget insists that “formal education could gain a great deal...from a systematic utilisation of the child’s spontaneous mental development” (p. 7).

Piaget (1964) was asked, at the conclusion of a lecture he had given, whether or not “the development of stages in children’s thinking could be accelerated by practice, training, and exercise in perception and memory” (p. 27). He answered in the negative and explained this in terms of figurative and operative aspects of cognitive function. He regards perception, mental imagery, imitation, etc. as being figurative aspects of cognition and actions or operations that lead to transformations as the operative aspect (Piaget, 1964). Because children in the sensorimotor or preoperational stages do not yet understand transformations and operations, he regards any exercise of perception and memory as reinforcing the figurative rather than urging the cognitive development on to the next level (Piaget, 1964).

His argument, therefore, is that the required prior learning needs to be in place for meaningful further development and learning to take place. This can be applied to the mathematics classroom. Requiring learners to practice substituting values into formulae to calculate measurements may result in their calculation of the correct value. However, if they have not

formed an accurate and stable conceptualisation of that object and its attributes, these solutions will be empty of meaning. The learner cannot be forced, through practice, into conceptual development. The requisite prior learning needs to be in place.

3.2.3 Some critiques of Piaget's theory

An often-cited criticism of Piaget's work is that his proposed age norms can be disconfirmed (Lourenço & Machado, 1996). Piaget's (1964) theory does rest on physiological maturation as a continuation of embryogenesis to explain cognitive development but he is not, however, of the opinion that this is the only influence. He acknowledges "the role of experience of the effects of the physical environments on the structures of intelligence [as well as] social transmission" (1964, p. 21), therefore also acknowledging that the physiological maturation upon which his age norms are derived are not necessarily accurate for all physical and social environments. Replication of his experiments across the world revealed that, while the ordering of his stages remained the same regardless of country, the ages at which children achieve preoperational, concrete operational and formal operational thought varied (Piaget, 1964). Piaget's theory, therefore, is not about what age each developmental stage is reached, but rather about its sequence (Lourenço & Machado, 1996, p. 144).

A recurring criticism of Piaget's work is that he does not consider the influence of social factors in accounting for development (Lourenço & Machado, 1996). That he makes no reference to an individual's self or personality and that he has extended his theory of forms of thinking to encompass all subjects irrespective of culture, are two of the criticisms levelled at his work (Lourenço & Machado, 1996). Piaget (1972) does, however, make it clear that, while not exclusively the result of social transmission, the:

formation and completion of cognitive structures imply a whole series of exchanges and a stimulating environment; the formation of operations always requires a favourable environment for 'co-operation', that is to say, operations carried out in common (e.g. the role of discussion, mutual criticism or support, problems raised as the result of exchanges of information, heightened curiosity due to the cultural influence of a social group, etc.) (p. 44)

Vygotsky (1926/1986) criticised Piaget on this point. Piaget's (1962) response upon reading this was to clarify that:

All logical thought is socialised because it implies the possibility of communication between individuals. But such interpersonal exchange proceeds through

correspondences, reunions, intersections, and reciprocities, i.e., through operations...[a]ctions, whether individual or interpersonal, are in essence co-ordinated and organised by the operational structures which are spontaneously constructed in the course of mental development (p. 11).

Piaget agreed that the environment, including the social environment, plays a role in cognitive development, but viewed interaction with this environment as being operational in itself. The interaction would therefore be of a nature fitting the developmental level of the child and would not shape the development itself.

3.2.4 Piaget in the context of this research

Piaget's relevance in this research is for the value his stage theory has in understanding the development of thinking in concepts, particularly measurement concepts. The ability to measure object attributes and to arrive at accurate conceptualisations of them, is reliant on the individual having interacted with their physical environment and operated on objects. Their eventual ability to apply hypothetic-deductive reasoning allows the measurement of object attributes in the absence of an object, and the conceptualisation of more complex measurements that represent relationships, such as rate. This is, however, dependent on the achievement of earlier stages of thought and prior knowledge and constructed conceptualisations derived from experiences with the environment.

3.3 DAVID TALL AND THE DEVELOPMENT OF MATHEMATICAL THINKING

David Tall's (2013b) neo-Piagetian work, detailing the development of mathematical thinking and three worlds of mathematics, is particularly useful in attempting to understand the development of measurement conceptualisations as well as understanding what prior knowledge is required to perform certain measurement tasks. As a student of Richard Skemp, Tall (2013b) was also influenced by his notions on the formation of mathematical concepts. This section opens with an outline of Skemp's (1989) work in that regard before proceeding with a description of Tall's (2013b).

3.3.1 Skemp and the formation of mathematical concepts

Skemp (1989) defines concepts as representing "not isolated experiences, but regularities abstracted from these" (p. 52). Learning is therefore about "discover[ing]...these regularities and organising them into conceptual structures which are themselves orderly" (p. 52). He writes

that the abstract nature of mathematics means that, from the earliest stages, conceptual learning is necessary if learners are to successfully move toward more abstract abilities.

In describing successive abstraction, Skemp (1989) distinguishes between primary and secondary concepts. Primary concepts he describes as being derived from sensory experiences, while secondary concepts are dependent on primary concepts for their definition (Skemp, 1989). An example would be ‘rectangle’ and ‘triangle’ which arise from an experience of such shapes in the environment and as such are primary concepts (Skemp, 1989). The definition of the term ‘shape’, which encompasses these two primary concepts, is a secondary concept (Skemp, 1989).

Secondary concepts can be further divided into lower-order and higher-order concepts. That the shapes hold further ‘attributes’, e.g. perimeter or area, would be a higher-order, secondary concept. As an object in the real world, a cube is a primary concept, but the fact that it belongs to a group called ‘prisms’ is a secondary concept. Further to this, that the cube has the attributes of surface area and volume is a higher-order secondary concept. In measurement, therefore, where the task is to measure attributes of objects, the understanding of which is built on an abstraction of primary concepts and lower order secondary concepts, conceptual learning is essential.

Skemp (1989) writes that, “[t]he process of abstraction involves becoming aware of something in common among a number of experiences, and if a learner does not have available in his own mind the concepts which provide these experiences, clearly [they] cannot form a new higher order concept from them” (p. 62).

Symbols, argues Skemp (1989), can aid the synthesis of ideas and concepts for a learner. They are “mental objects about which and with which we can think...[or] physical objects – marks on paper, sounds – which can be seen or heard” (p. 90). Once attached to a mathematical concept, symbols facilitate one’s own access to the concepts as well as allowing for communication between individuals.

3.3.2 David Tall and the development of mathematical thinking

According to Tall (2006), the development of mathematical thinking requires “powerful ideas to be compressed into thinkable concepts that apply in new situations” (p. 1). Flexibility in mathematical thinking arises as a learner builds on experiences that influence how they

interpret new ideas (Tall, 2013a), as is argued by Piaget (1964) and Skemp (1989). How learners then complete a mathematical task is based on an individual learning trajectory built on met-befores. A met-before is defined as a “mental structure that we have now as a result of experiences we have encountered before” (Tall, 2013a, p. 5). These met-befores can, understandably, be either supportive or problematic (Tall, 2013a). It is therefore important to explore the prior knowledge students have about measurement in order to inform the way forward in terms of their learning of it as is the aim of this research.

3.3.2.1 Proceptual thinking

Gray and Tall (1994) provide a multi-faceted explanation of the development of thinking in concepts that is useful in considering mathematical expertise. They introduced the idea of a procept as an “amalgam of process and concept” (p. 116). Symbols act as pivots, which can switch from a process to a concept: adding two numbers would be a process (e.g. $3+4$), whereas the concept would be that the sum of $3+4$ is 7 (Pegg & Tall, 2005). This proceptual fact is not the same as a rote learned fact. Proceptual understanding is characterised by a “rich inner structure which may be decomposed and recomposed to produce derived facts” (Gray & Tall, 1994, p. 118).

3.3.2.2 The development of mathematical thinking

Tall (2008, p. 1) outlines what he terms the “three worlds of mathematics”: the conceptual-embodied world; the proceptual-symbolic world and the axiomatic-formal world. Conceptual embodiment arises as innate mental structures develop with brain maturation, particularly “recognition of patterns; repetition of sequences of actions and the [use of] language to describe and refine how we think” (p. 6). Knowledge structures are built and categorised according to what we think about and perceive. This is facilitated by our practical interaction with the physical world, as is argued by Piaget (1964).

Growing out of the embodied world is the proceptual-symbolic world in which physical actions and experiences become symbolised as “processes to do and concepts to think about” (Tall, 2008, p. 7). Reliant on the cognitive development in these two worlds is the formal-axiomatic world where formal concepts are based on linguistic definitions that will have been formed during prior developmental stages (Tall, 2008). This is the most sophisticated level of mathematical thinking.

Tall (2013b, p. 13) provides a model of three different ways of thinking in mathematics:

- (Conceptual) embodiment – builds on human perceptions and actions developing mental images that are verbalised in increasingly sophisticated ways and become perfect mental entities in our imagination
- (Operational) symbolism – develops from embodied actions into symbolic procedures of calculation and manipulation that may be compressed into procepts to enable flexible operational thinking
- (Axiomatic) formalism – builds on formal knowledge in axiomatic systems specified by set-theoretic definition, whose properties are deduced by mathematical proof.

These encompass three spheres of mathematics, those of practical mathematics, theoretical mathematics and formal mathematics. Formal mathematics is described by Tall (2013b) as that encountered at university level. This would be encountered by those students wishing to pursue engineering as a profession. For NC(V) students preparing initially to enter the workforce as artisans, the first two worlds are most relevant and form the focus of this research. Tall (2013a) describes these as comprising natural mathematics, which is based on “perception, operation and imagination” (p. 2).

Tall’s (2013b) definition of practical mathematics is that which involves “recognition and description of ideas in space and shape and the practical experience of arithmetic based on growing familiarity with the operations and the effects of those operations” (p. 30). Physical measurement of objects, using measuring equipment would constitute practical mathematics. Theoretical mathematics is defined as involving the use of the properties that have been observed as “definitions that can be used as the basis of deduction and proof” (p. 30). Once learners have been introduced to the use of formulae to calculate various measurements, in the absence of the object to which the measurement refers, they would be able to engage in theoretical mathematics.

The figure below shows Tall's (2013a, p. 2) organisation of these ideas:

Figure 3.1 Tall's organisation of mathematical thinking and development

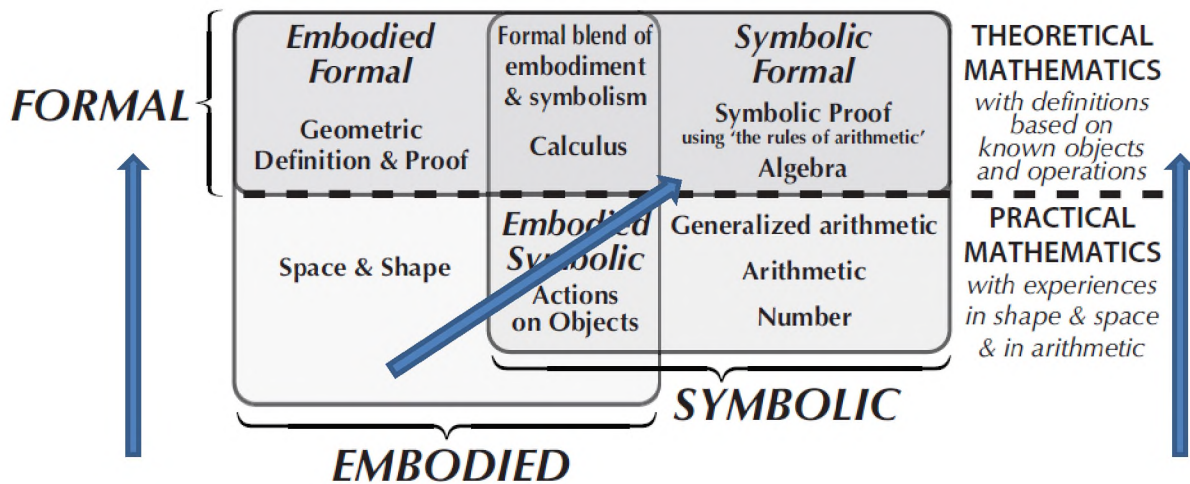

Tall (2013a, p. 2)

There are three directions in which Tall (2013b) claims the development of mathematics proceeds. First, from the embodied world in practical mathematics to the embodied formal world of theoretical mathematics; secondly, from the symbolic world in practical mathematics to the symbolic formal world of theoretical mathematics, and lastly, from embodiment to symbolic formal work. These are indicated by the arrows on Figure 3.1. This notion of progression is reflected in the expected learning trajectory regarding measurement in South African curricula. Learners first encounter measurement in a strongly embodied way, and work in increasingly abstract and symbolic ways with measurements as they progress through their schooling.

3.3.3 Applying Tall's theory to measurement

Tall's (2013b) theory is a useful lens with which to view both the expected learning trajectory for South African learners and students in terms of their measurement learning within the confines of the school curricula, as well as the measurement activities themselves. In Tall's (2013b) own words, "measurement requires the blending of embodiment and symbolism" (p. 188). It develops initially from embodied actions, e.g. the physical measuring of length, to where learners are expected to apply symbolic formal thought to calculate measurements in the absence of the object to which the measurements apply.

3.3.3.1 Classifying measurement tasks

A mapping of the South African mathematics curricula was provided in Chapter 2 (see Section 2.7 and Appendices E - I), and the foci of each curriculum classified as either exclusively focused on the use of physical measurement or the use of formulae to calculate measurements. In some cases, there was a dual focus.

Figure 3.2 provides examples of assessment items from the 2015 ANAs for Grade 4 and Grade 5 (DBE, 2015a; 2015b). It is evident that the work, while being assessed in a pen and paper test, is closely linked to physical measurement. The Grade 5 example requires that learners know the definition of a rectangle and the definition of perimeter, but does not require the use of any formula. It does, however, provide evidence of a slight move toward more symbolic understanding, while requiring function in the conceptual embodied world.

Figure 3.2 Grade 4 (left) and Grade 5 (right) ANA test items

The figure consists of two rectangular boxes representing test items. The left box is for Grade 4 and contains the following text: "Look at the lengths of the various pictures below and answer the questions that follow." Below this text are three items: a nail, a pencil, and a ruler. The ruler is marked in millimeters from 0 to 110. Below the ruler are two questions: "7.1 The length of the pencil is _____ mm." and "7.2 What is the difference between the length of the pencil and the length of the nail?". The right box is for Grade 5 and contains the following text: "Calculate the perimeter of a rectangular soccer field with the measurements as indicated in the diagram." Below this text is a diagram of a rectangle labeled "Soccer field". The top side is labeled "5 m" and the right side is labeled "11 m". Below the diagram are two horizontal lines for writing the answer.

(DBE, 2015a, p. 7; 2015b, p. 11)

In Figure 3.3 an excerpt from the Grade 6 2016 workbook issued by the DBE (2016a). It shows a decisive shift to symbolic work in measurement., and it is clear that learners are starting to use formulae to calculate measurements. The Grade 7 ANA item, in Figure 3.4, reveals that the use of this formula to calculate the volume of a rectangular prism should have been established by the end of that grade. Grades 6 and 7 maintain a dual focus, but with a shift evident towards formal symbolism.

Figure 3.3 Introducing the calculation of volume in a Grade 6 workbook

Talk about the 3 solutions

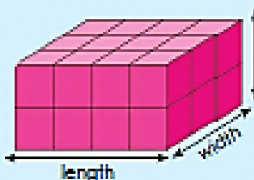

The length equals 4 units
The width equals 3 units
The height equals 2 units

Solution 1:
 $12 + 12$
= 24 cubic units

Solution 2:
 $8 + 8 + 8$
= 24 cubic units

Solution 3:
 $4 \times 3 \times 2$
= 24 cubic units

1. Give three ways to calculate the cubic units of the object

a.

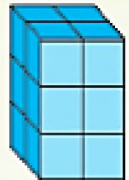

Solution 1:

Solution 2:

Solution 3:

(DBE, 2016a, p. 156)

Figure 3.4 Grade 7 ANA test item

In the rectangular prism below, the length = 5 cm, the breadth = 3 cm and the height = 10cm.

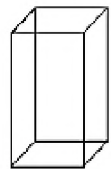

Calculate the volume of the rectangular prism.

(DBE, 2015c, p. 14)

It can be seen in the Grade 9 ANA item below (Figure 3.5), as well as the Grade 12 Mathematics NSC examination item (Figure 3.6), that learners are required to work in the symbolic formal world using definitions of objects and operations to calculate measurements. In the Grade 9 items, the Theorem of Pythagoras and the definition for the area of a circle are required, and the Grade 12 NSC item requires the application of the definitions for the calculation of the volume of a cone in a practically-oriented calculus problem.

Figure 3.5 Grade 9 ANA test items

In $\triangle PQR$, $PT \perp QR$, $PQ = 10$ cm, $QT = 6$ cm and $TR = 15$ cm.

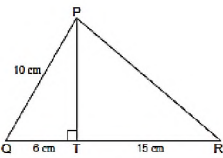

12.1.1 Calculate the length of PT .

The area of a circle is equal to πr^2 .
 Calculate the length of the radius of a circle of area = 120,7 cm². Write the answer correct to 2 decimal places.

(DBE, 2015d, pp. 18-19)

Figure 3.6 Grade 12 Mathematics NSC examination item

A rain gauge is in the shape of a cone. Water flows into the gauge. The height of the water is h cm when the radius is r cm. The angle between the cone edge and the radius is 60° , as shown in the diagram below.

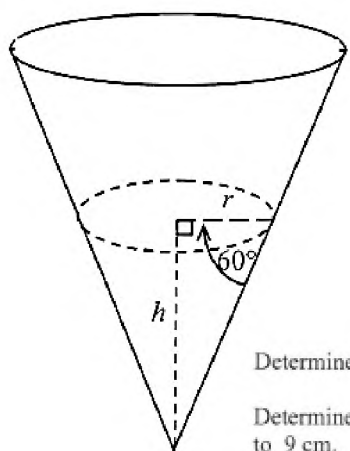

Formulae for volume:

$$V = \pi r^2 h \qquad V = \frac{1}{3} \pi r^2 h$$

$$V = lbh \qquad V = \frac{4}{3} \pi r^3$$

Determine r in terms of h . Leave your answer in surd form.

Determine the derivative of the volume of water with respect to h when h is equal to 9 cm.

(DBE, 2015g, p. 9)

The NSC Mathematical Literacy (DHET, 2016b) examination paper provides an excellent example of a problem which maintains a link to the conceptual embodied world while requiring students to operate in the symbolic formal world. It reveals the dual nature of the focus in NSC mathematical literacy, but also provides an illustration arguing for the point that real-world measurement requires a blend of conceptual embodiment and operational symbolism. The practical use of measurement in the real world can otherwise not be realised.

Figure 3.7 Grade 12 Mathematical Literacy NSC examination item

- 5.1 Mrs Dundee, an Australian farmer, has four silos on her farm in which she stores fertiliser, as shown in the photograph and diagram below. The silos are cylindrical with a roof section. Fertiliser is only stored in the cylindrical part of the silos.

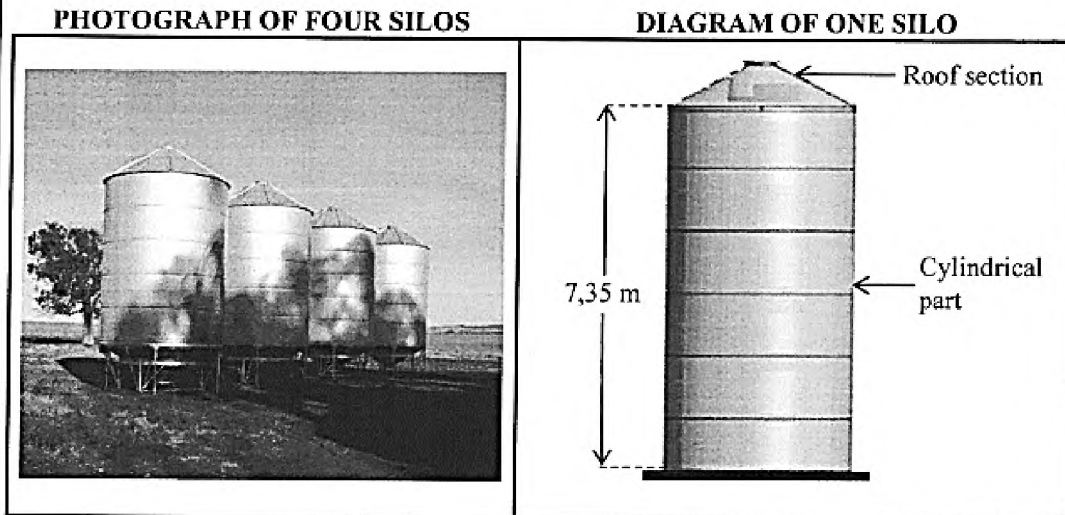

[Source: www.cicrobulk.co.za]

The following formula and conversion rates may be used:

Volume of a cylinder = $\pi \times (\text{radius})^2 \times \text{height}$; using $\pi = 3,142$

1 m³ = 1 000 ℓ

1,3 kg = 1 litre

1 gallon = 3,7 litres

- 5.1.1 Calculate the diameter of a silo if the volume of the cylindrical part is 60 m³. (5)
- 5.1.2 Calculate the total maximum capacity (in gallons) of the four silos. (4)
- 5.1.3 After fertilising all her main fields, Mrs Dundee wants to use the remaining fertiliser for a wheat field, which is 1 055 acres in size.
- The capacity readings of the four silos are as follows:
- Silo 1: 15% full
 - Silo 2: $\frac{1}{4}$ full
 - Silos 3 and 4: empty

Verify, showing ALL calculations, whether she will have enough fertiliser left in her silos for the wheat field if the spread rate is 22,65 kg of fertiliser per acre. (6)

(DBE, 2016b, p. 10)

3.3.3.2 Using Tall to understand the measurement learning trajectory

The following flow diagram shows the path from Grade 4 to the FET Band, comprising the NSC subjects as well as the NC(V) subjects. It classifies the focus of each grade according to Tall's (2013b) three worlds. Where the focus of a particular grade is exclusively on physical measurement, it is classified as 'conceptual embodiment'; where there is a dual focus on physical measurement and calculation using formulae, it is classified as 'transitional/blend' and if the focus is exclusively on calculation using formulae and definitions, it is classified as 'formal symbolism'.

Figure 3.8 Applying Tall to the measurement learning trajectory in South African school curricula

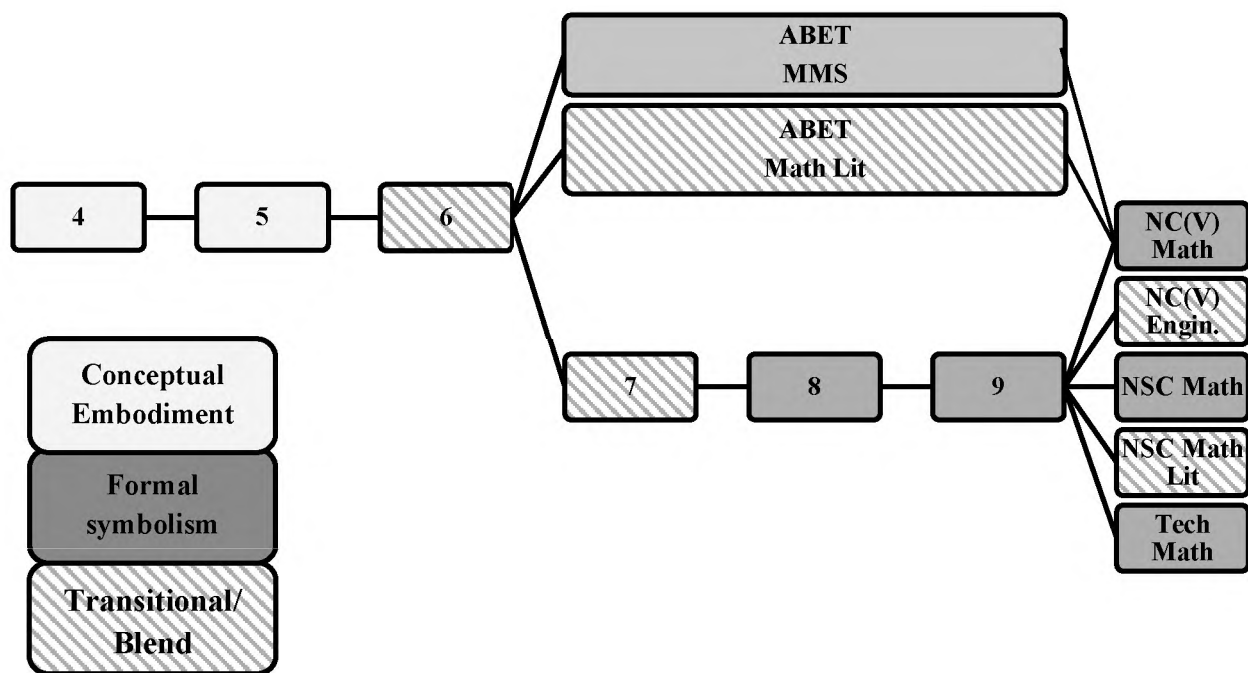

Regardless of the path taken, the trajectory proceeds from conceptual embodiment to increasingly symbolic and formal calculations. If we look back to Tall's (2013b) model, and the diagonal developmental trajectory he proposed, it is worth noting that the embodied world becomes separated (see Figure 3.9). According to this model, once operating with formal symbolism alone, no link exists to the embodied world.

Figure 3.9 Tall’s diagonal development trajectory

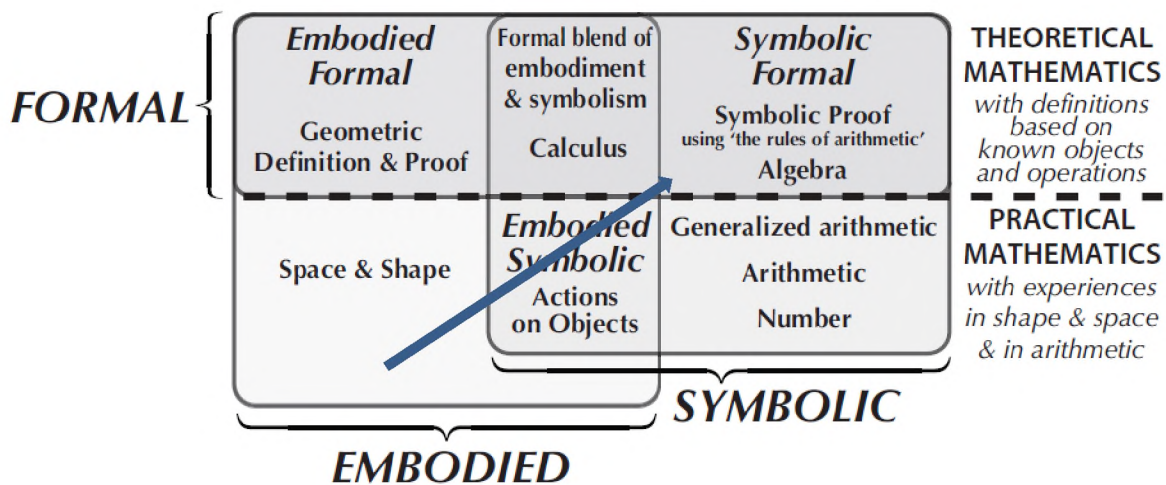

Tall (2013a, p. 2)

The expected measurement learning trajectory established for South African learners (see Section 2.7) mirrors Tall’s (2013a) diagonal trajectory, thus similarly losing the link to the embodied world as students progress through the grades

3.4 MEASUREMENT

There is a distinction that needs to be drawn between spatial object measurement and more complex measurements that are required by engineers. The overwhelming focus at school level is on spatial object measurements. Objects possess attributes that can be measured directly, e.g. perimeter, area or volume and learners are taught how to physically and symbolically do so. Engineers, however, need to be competent in complex measurement and it is this about which there is very little research published.

The dominant focus in spatial object measurement at school, and the fact that learners are not performing well in this, means that the learning and teaching of this type of measurement, at primary school level, has been the most obvious need regarding research in measurement education. This dominant focus, however, also means that engineering students are likely to encounter complex measurements for the first time late in their schooling if not only during their post-school qualification.

This section will define object measurement, and explore each domain of measurement relevant to this research, including the more complex measurement of rate.

3.4.1 What is object measurement?

Gooya, Khosroshahi and Teppo (2011, p. 709) define measurement as “the process of assigning a numerical value to an attribute of an object by comparing the attribute to some preselected unit”. Piaget, Inhelder and Szeminska (1960) explain that “to measure is to take out of a whole one element, taken as a unit, and to transpose this unit on the remainder of a whole: measurement is therefore a synthesis of subdivision and change of position” (p. 3). In order to do this, the learner “requires the understanding that (a) the size of the unit is conserved and (b) that the unit can be used iteratively” (Nunes, Light & Mason, 1993, p. 40).

Measurement not only requires bodily movement and transposing of unit objects, it also requires representation of this change of position and linkage to reference points (Piaget et al., 1960). If the length one rod (A) is measured with reference to a smaller rod (B), as depicted in **Figure 3.10**, the length measurement after iterating B along the length of A would be 8 *small rods*. The numeral 8 represents the change of position and the ‘small rod’ is the referent unit.

Figure 3.10 Iteration of unit (B)

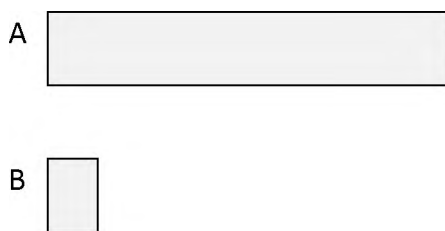

Feikes et al. (2008) outline several key related underlying concepts of measurement that further clarify the process Piaget et al. (1960) are describing. These generalise across measurement domains:

Iteration or repeating a unit:

“Measurement involves learning to repeat a unit and the mental ability to place the unit end-to-end” (Feikes et al., 2008, p. 218). This includes leaving no gaps between successive units, and allowing no overlaps.

Partitioning or subdividing:

“Partitioning is the mental activity of slicing up an object into the same sized units” (p. 219).

Number and measurement (Measurement is more than counting):

This refers to the understanding that “different numbers can be used to represent the same distance if one uses different units of measure” (p. 219)

Transitivity and Conservation:

Transitivity refers to the ability to order quantities according to their measure (Piaget, 1970), for example, placing different length segments in order from longest to shortest. Conservation, for example, of length means that if an object is moved or its parts rearranged, its length does not change (Piaget, 1970).

Smith et al. (2011) summarises: “In measurement, a continuous quantity becomes discrete when we choose a suitable unit and iterate that unit to determine the number of copies to exhaust the quantity. Its measure is the count of those units” (p. 618).

3.4.2 Units in measurement

It is clear, from the definitions of measurement offered above that the notion of a unit is critical. Barrett et al. (2011, p. 638) notes that “comparative reasoning underlies every act of measurement” in that every time one measures, a particular object is related to another unit object, resulting in a measure in terms of the unit object.

Barrett et al. (2011) highlight that students frequently have poorly formed unit concepts, and that while some may be able to use unit names accurately to label a quantity, they are often not able to provide an explanation of the meaning of this unit. They cite as an example students who are unable to make use of a broken ruler to measure the length of an object (Barrett et al, 2011). Outhred and Mitchelmore (2000, p. 144) explain that how “units fit together spatially and how they may be counted systematically are unique to each domain of application”. There are certain quantities for which students experience particular difficulty in conceptualising the unit (Sarama & Clements, 2009). Sarama and Clements (2011) mention area and volume among these. Students count lengths when measuring area and count faces when measuring volume (Sarama & Clements, 2009).

Interestingly, MacDonald (2011), in research conducted in Australia with children of 4 to 6 years old, found that some of these children “were able to demonstrate equal partitioning of units and represent this in a spatially appropriate manner” (p. 487). There were children who

were even able to explain the purpose of the units in the measurement of the length of a piece of paper (MacDonald, 2011). Although these children would not yet have started formal schooling, the beginning of the development of the concept of units in measurement became evident, and was more sophisticated than expected (MacDonald, 2011). The findings suggest that should these developing conceptualisations be better understood, perhaps “in-school measurement learning [could be made] more relevant and meaningful” (p. 490) and later difficulty with unit concepts minimised.

3.4.3 Rational numbers in measurement

Lamon (2008) explains that when students start working with natural numbers, measurement takes its simplest form in the counting separable objects. When they begin to encounter rational numbers, the measurement of continuous quantities becomes possible (Lamon, 2008). This is done by segmenting the quantity to form whole units, then subdividing the whole units and iterating the resulting part units to determine the measurement.

As Gooya et al. (2011, p. 710) point out, “units of measure can be used in fractional ways as well as [by] iteration of the whole unit”. Measurement of discrete, separable objects is easier, according to Yujing and Zhou (2005), as the units are already subdivided and all that is required is to count. Measurement of continuous quantities, however, is more difficult as “continuous amounts need to be segmented [or subdivided] into equal units before they can be enumerated” (p. 39).

In subdividing the unit into fractional pieces, the degree of precision of the resulting measurement is increased (Gooya et al., 2011; Lamon, 2008). The density of rational numbers, that “there is an infinite number of fractions between any pair of fractions” (Lamon, 2012, p. 213), or rather that “between any two numbers there is always an intermediate number, which implies that there are infinitely many intermediaries” (Vamvakoussi & Vosniadu, 2010, p. 181), is what allows this increase in precision.

The notion of discreteness of natural numbers, however, can provide a stumbling block to students’ understanding of rational number density (Vamvakoussi & Vosniadu, 2010). Torbeyns, Schneider, Ziqiang and Siegler (2015) write that it is frequently the case that students’ early understanding of natural numbers can interfere with the development of understanding of rational numbers. They write that “faulty generalisation of understanding of number as counting units [can] interfere with...learning of fractions” (p. 6). This is known as

natural number, or whole number, bias (Torbeys et al., 2015), an example of which would be if a student assigns a value of $\frac{1}{x}$ (where $x \neq 0$) to a section of a whole unit and assigns a value of $\frac{1}{x+y}$ (where $y > 0$) to a larger piece of the same unit. The student has, in this case, erroneously applied their natural number understanding that a larger number indicates a larger measure. When working with fractions a larger denominator indicates a smaller measure if the numerator is constant. Students can also hold similar misconceptions regarding the magnitude of decimals (Durkin & Rittle-Johnson, 2015, p. 21), believing, for example, that $0.1004 > 0.102$ because $1004 > 102$. Vamvakoussi and Vosniadou (2010, p. 182) indicate that “typically this phenomenon is explained as an adverse effect of students’ prior knowledge and experience with natural numbers”.

Barrett et al. (2011, p. 638) explain that “measurement units are closely related to rational number units and proportional thinking”. In their research, they proposed teaching the unit concepts of length, area and volume concurrently, rather than in a sequence. Their argument was that in integrating unit concept development in multiple dimensions concurrently, students would acquire an understanding that “measures are in fact ratios between a unit quantity and other quantities” (p. 647). This is a sophisticated level of knowledge of measurement and requires proportional thinking (Barrett et al., 2011). Rational numbers, unit conceptions and measurement are therefore inseparable concepts.

3.4.4 Estimation

Competence in measurement includes the essential numeracy skill of estimation (Gooya et al., 2011). When physical tools are unavailable or impractical to use, one needs to be able to make a quick judgment about the magnitude of the attribute being measured, in other words an estimation (Gooya et al., 2011). As Gooya et al. (2011) explain, it is as learners gain experience using measurement tools, that they develop a sense of the magnitude of a particular unit and thereby develop in their ability to perform estimations. As the following quote highlights, this is a complex task. It involves:

“recalling an image of a standard unit..., repeatedly comparing that image to the object that is to be estimated, keeping track of where the last unit ended and the next one should begin, and maintaining a running tally of the units while continuing

to perform the tasks [mentioned]” (Joram, Gabriele, Bertheau, Gelman & Subrahmanyam., 2005, p. 5).

One method of estimation would be to mentally hold an image of a single unit as it would appear on a standard measuring tool and estimate based on an image of this unit and its iteration. Another strategy is to form a mental reference point. This is “an object to which an estimator can psychologically connect a measurement unit or multiple units” (p. 5). This may include such connections as: the width of a thumb is approximately equal to 1cm or $\frac{1}{2}$ of the height of a door is approximately 1m. Having internalised this mental reference point, the learner moves to being able to mentally measure objects by iterating this ‘object’ and counting the number of iterations (Joram et al., 2005).

Estimation requires knowledge and application of the core principles of measurement, for example, that units should be iterated with no gaps or overlaps, and units should be equal in size. It is possible that a learner may be able to read measurements from a measurement tool, like a ruler, but be unable to estimate as the principles of measurement are not understood. The tool provides the correctly iterated, equally sized units, and it is not necessary to mentally apply the principles of measurement. Joram, Subrahmanyam and Gelman (1998, p. 414) therefore highlight the value of using estimation in the classroom as a “convenient conduit for teaching the principles of measurement”.

3.4.5 Conceptual and procedural knowledge in measurement

When considering measurement, it is useful to consider the distinction between conceptual and procedural knowledge. Hiebert and Lefevre (1986, p. 6) define procedural knowledge as comprising “the formal language, or symbol representation system, of mathematics [and] the algorithms, or rules, for completing mathematical tasks”. They contrast this with conceptual knowledge “that is rich in relationships..., a connected web of knowledge... in which the linking relationships are as prominent as the discrete pieces of information” (p. 4). Lima & Tall (2010) describe the fragility of a procedural approach. It becomes an obstacle when encountering new but related learning. It is acknowledged, however, that mathematical knowledge, if it exists in its fullest sense, must include significant relationships between the two.

Key measurement activities include, most fundamentally, the act of measuring, as well as conversion and computation (Preston & Thompson, 2004). It is, however, possible that students

use measurement tools, apply formulae and perform conversions in a routine manner with some success, but to be proficient at measuring, students also need to have a conceptual understanding of what they are doing (Preston & Thompson, 2004). They need this in order to estimate, as explained in the previous section, as well as to select the correct measurement tool, select the most appropriate unit and engage in the reasoning required to think critically about measurement (Preston & Thompson, 2004).

Lamon (2008) distinguishes between the *act of measuring* and *measurement* and emphasises that this is a critical distinction to make. She, like Preston and Thompson (2005), explains that students may be able to “carry out the act of measuring with reasonable accuracy (i.e. choosing a unit of measure and displacing it without overlap or empty intervals)” (Lamon, 2008, p. 40) but that this does not guarantee that the student has grasped the conceptual principles of measurement. In school, however, measurement is often taught as procedures, and students are frequently not afforded the opportunity to grapple with the foundational concepts of measurement (Lehrer, Min-Joung & Jones, 2011). As Tan-Sisman and Aksu (2016, p. 1311) write, it is “both knowing *how* to...measure and knowing *what* and *why* to measure” that are important.

3.4.6 Domains of measurement in this research

The domains of measurement addressed in this research are those of area, volume and flow rate. Area and volume were selected as they are the dominant focus of school curricula, and therefore represent domains in which every student would have constructed measurement conceptualisations.

Flow rate is a slightly more complex measurement. It is defined as a relation between two quantities: volume and time, and has been included in the research for the insight it can bring as to how students work when measuring non-spatial attributes linked to objects. In addition, this is not a concept that students will have worked with previously. Because speed is, similarly, a rate, the work of Thompson and Thompson (1994; 1996), regarding the learning of the concept of speed is included.

3.4.6.1 Area measurement

As Cavanagh (2008) describes, area measurement finds its basis in the iteration of a unit until a flat surface is completely covered, with no gaps or overlaps. Sarama and Clements (2009)

propose a developmental progression for area measurement from ‘pre-area qualitative recognition’ in which a child of 0 – 3 years of age would be perceiving just “space and objects within that space” (p. 300).

What is described here is the progression from the stage at which students start applying an explicit understanding of area (Sarama & Clements, 2009), as this holds relevance for older students who have had prior experience in the formal measurement of area. Table 3.1 summarises Sarama and Clements’ (2009) progression. The examples provided refer to measurement of a rectangular surface with whole units that require no subdivision. One row and column, subdivided according to the unit, was provided within the rectangle, as shown in the figure below:

Figure 3.11 Row and column subdivision

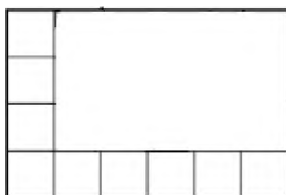
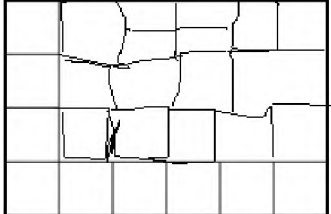
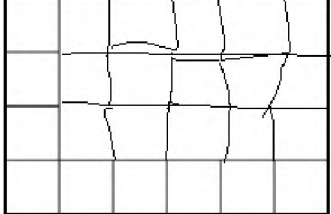
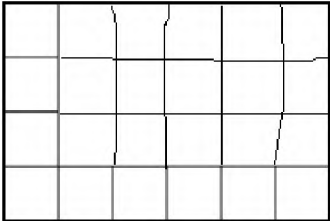

Table 3.1 Area measurement progression

Area/Spatial Structuring	Description	Example
Primitive Coverer	<p>Draws a complete covering, but with some errors of alignment.</p> <p>Counts around the border, then unsystematically in the interior, counting some twice and skipping others.</p>	
Area Unit Relater and Repeater	<p>Draws as above, but can also tile area using manipulatives and counts correctly, aided by counting one row at a time</p>	<p>(from Sarama & Clements, 2009, p. 302)</p>
Partial Row Structurer	<p>Draws and counts some, but not all, rows as rows.</p>	

	<p>May make several rows and then revert to making individual squares, but aligns them in columns.</p> <p>Does not coordinate the width and height.</p>	(from Sarama & Clements, 2009, p. 302)
Row and Column Structurer	<p>Draws and counts rows as rows, drawing with parallel lines.</p> <p>Counts the number of squares by iterating the number in each row, either using physical objects or an estimate for the number of times to iterate.</p> <p>Those who count by ones usually do so with a systematic spatial strategy (e.g. row by row)</p>	 <p>(from Sarama & Clements, 2009, p. 303)</p>
Area Conserver	<p>Conserves area and reasons about additive composition of areas (e.g. how regions can look different but have the same area) and can recognise the need for <i>space filling</i> in most contexts</p>	
Array structurer	<p>With linear measures or other similar indications of the two dimensions, multiplicatively iterates squares in a row or column to determine the area.</p> <p>Drawings are not necessary, children can compute the area from the length and width of rectangles and explain how that multiplication creates a measure of area.</p>	

Adaptation of Sarama and Clements, 2009, pp. 302-304

The summit of development in area measurement, according to this progression, would be where students no longer require a surface, or a drawn representation of a surface, to measure area. Rather they are able to calculate the area of a rectangular surface given only its length and width (Sarama & Clements, 2009). This is symbolic formal work (Tall, 2013b). Students apply formulae at this level in order to calculate the area of a surface in the absence of the object to which the problem refers.

It is important to note that at the ‘array structurer’ level, students can “explain how...multiplication creates a measure of area” (Sarama & Clements, 2009, p. 304). This requires a conceptual grasp of area measurement. Cavanagh (2008) cautions that students who are able to use a formula to calculate area do not necessarily have the conceptual understanding

to explain how the formula works. It is possible for the student to apply the procedure, without needing to rely on a conceptual grasp of how and why it works (Cavanagh, 2008).

Baturo and Nason (1996, p. 239) note that the “formal cultural practice of calculating area measurements” can occlude the conceptual nature of the task. This practice is not to physically apply area units, but rather “to obtain two measures of length and use them in formulae that will give a result in area unit” (Baturo & Nason, 1996). We do not use, as with length, a tool (e.g. a ruler) that will physically allow measurement of the quantity. Area is calculated indirectly from two linear measurements.

Outhred and Mitchelmore (2000, p. 145) write that poor performance in area measurement is often attributed to the “tendency to learn the formula by rote”. They cite as an example students who were able to calculate the area of a rectangle when provided with the length and width, but who were unable to calculate the area of a square when provided with the length of only one side, despite knowing that a square has four equal sides (Outhred & Mitchelmore, 2000). The students “[did] not understand the conceptual basis for the formula [and had] difficulty in generalising the procedure they ha[d] learned” (p. 145). A similar observation was made by Cavanagh (2008), who noted that the Grade 7 learners in his research had difficulty understanding the relationship between rectangular and triangular areas. They did not “make use of the fact that the area of a triangle is half that of the rectangle which shares a common base and perpendicular height” (p. 57), thus revealing an inability to generalise the procedure of calculating the area of a rectangle to find a method for calculating the area of a triangle.

Tan-Sisman and Aksu (2016) conducted a study in which students’ misconceptions and errors in conceptually and procedurally-oriented measurement tasks were explored. Their research revealed that the following were common areas of difficulty for students when measuring area:

- (a) realising how length units produce area units
- (b) grasping the conservation of area
- (c) understanding array and grid structure
- (d) comprehending two-dimensional structure of area
- (e) understanding the difference between not only the concept of area and perimeter, but also the formulae for these concepts

They seem able to apply basic formulae to shapes with which they are most familiar, but when required to generalise, or deduce a formula, the conceptual weaknesses in their understanding are exposed.

3.4.6.2 Volume measurement

Similar to their proposed developmental progression for area measurement, Sarama and Clements (2009) also propose a developmental progression for volume measurement. At the earliest level, a child of 0 – 3 years of age would again simply “perceive space and objects within that space” (p. 306), although rather than in 2 dimensions, this is in relation to volume or capacity. This level is called ‘volume quantity recogniser’ (Sarama and Clements, 2009). What is described here is the progression from the stage at which students are able to visualise a space as being filled with objects (Sarama & Clements, 2009), as this holds relevance for older students who have had prior experience in the formal measurement of volume. Table 3.2 summarises Sarama and Clements’ (2009) proposed progression.

Table 3.2 Volume measurement progression

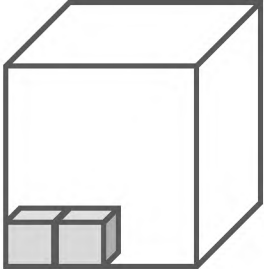
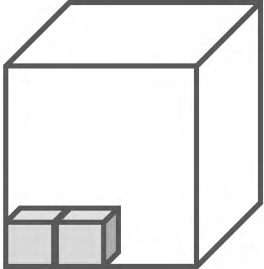
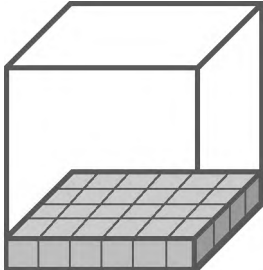
Volume/Spatial Structuring	Description	Example
Primitive three-dimensional [3D] Array Counter	<p>Partial understanding of cubes as filling a space.</p> <p>May eventually count one cube at a time in carefully structured and guided contexts, such as packing a small box with cubes.</p>	<p>Packing a small box with cubes:</p> 
Capacity Relater and Repeater	<p>Uses simple units to fill containers, with accurate counting.</p> <p>Can fill a container by repeatedly filling a unit and counting how many.</p>	
Partial 3D Structurer	<p>Understands cubes as filling a space, but does not use layers or multiplicative thinking.</p> <p>Moves to accurate counting strategies, e.g. counts the number of cubes in one row or column of a 3-D structure and uses skip counting to get to the total.</p> <p>Applies the composite unit (i.e. the row or column) repeatedly, but not</p>	<p>One layer forming a composite unit</p> 

	necessarily exhaustively as its application remains intuitive.	
3D Row and Column Structurer	As with <i>Partial 3-D Structurer</i> but applies the composite unit repeatedly and exhaustively to fill the 3-D array	
3D Array structurer	Can compute the volume of rectangular prisms from their dimensions and explain how that multiplication creates a measure of volume. Constructions and drawings are not necessary.	

Adaptation of Sarama and Clements, 2009, pp. 306-308

Of the relationship between length, area and volume, Sarama and Clements (2009, p. 302) write that measurement of area and volume “leads to multiplicative relationships involving the lengths of the sides”. This is relevant to the final stage in the area and volume progressions they propose, where drawings are no longer necessary if the linear dimensions of the object are known to the student. At this level the procedure for area and volume measurement becomes purely symbolic. Outhred and Mitchelmore (2000, p. 145) emphasise that as with area measurement, “student difficulties in volume measurement have also been linked to an early emphasis on formulae”.

Sarama and Clements (2009) note that constructions and drawings representing volume are no longer necessary in order for students to compute volume at the 3D array structurer level, but this cannot be taken imply that constructions and drawings simplify the task of measuring volume. Ben-Haim, Lappam and Houang (1985) explains that the representation of a three-dimensional world in two-dimensions is complex to interpret, and “by no means immediately recognisable” (Ben-Haim et al., 1985, p. 389). For example, to measure the volume of the block shown in Table 3.2, in which the diagram is subdivided according to the cubic unit to be used requires the student to first correctly visualise the object from the diagram, and then to mentally manipulate it in order to ‘read’ how many unit blocks it comprises (Ben-Haim et al., 1985). This is a complex visualisation task that also requires a sound conceptual understanding of volume in order to count the number of cubic units making up the object.

Tan-Sisman and Aksu's (2015) research also explored student errors and misconceptions related to volume measurement. Their findings revealed the following common areas of difficulty:

- (a) treating three-dimensional figures as two-dimensional ones
- (b) counting visible faces/unit cubes
- (c) enumerating the cubes in 3D arrays incorrectly
- (d) confusing the concept of volume with the concept of surface area and their formulae

As was evident in the listed 'areas of difficulty' for area, those listed for volume are conceptual. Students were not operating with a clear and accurate conception of volume.

3.4.6.3 Measurement of rates

The measurement of more tangible quantities, like those of length, area and volume already discussed, leads to composite quantities, such as rates (Smith et al, 2011). Kent, Bakker, Hoyles and Noss (2011, p. 748) explain that "measurement of material objects is common in the workplace, but the data generated by taking measurements are frequently used for a subsequent layer of measurement in terms of abstract constructs". A rate may be considered such a concept.

The scientific concept of a rate is a combination of basic measurement concepts (Basson, 2002), like that of distance and time in relation to speed. Lamon (2012, p. 242) describes speed as "the most important rate" as it is one that we all encounter every day and while speed can be considered a more abstract construct, it is a one that is directly experienced. Speed is "a quantification of motion" (Thompson & Thompson, 1994, p. 284) and motion is a concept that even young children have an everyday understanding of (Thompson, 1994).

Lamon (2012) explains that we all encounter the distance-time-speed relationship daily and that most students will have encountered the formula $speed = distance \div time$. The actual system of the relationships between the three, however, takes a long time to understand (Lamon, 2012). For example, if the distance travelled by an object is divided by the amount of time the object was travelling, one obtains a value with a new structure. The resulting value reflects distance, reported according to a selected unit of length, subdivided per selected unit of time, e.g. if 200 kilometres are travelled in two hours, the speed is 100km/h. Speed is therefore "quantified motion" (Thompson, 1994, p. 205). Thompson (1994) cautions, however,

that to introduce students to the concept of speed with the definition of *distance divided by time* denies them the opportunity to construct for themselves the concept of speed as a rate.

Thompson (1994, p. 182) states that “one crucial part of sound mathematical development is students’ construction of powerful and generative concepts of rate”. Lamon (2012, p. 236) defines rates as “descriptions of the way quantities change with time... they are identified by the use of the word per in their names and they can be reduced (or divided) to a relationship between one quantity and 1 unit of another quantity (a unit rate)”.

Thompson’s (1994, p. 189) more formalised explanation of rate is that it is a type of quantitative operation, where “a quantitative operation is a mental operation by which one conceives of a new quantity in relation to one or more already-conceived quantities”. This creates a structure, a new quantity that relates to the original quantities operated on (Thompson, 1994). Rate is the result of “the quantitative operation of comparing two quantities multiplicatively, originat[ing] in matching and subdividing with the goal of sharing”.

Consider the example of speed. Speed can be described as the distance travelled in a particular amount of time (Thompson, 1994), thus distance and time are the two quantities to be operated on in order to establish a measure of the speed. It is a “created quantity in relation to the quantities operated upon to make it” (Thompson, 1994, p. 191). The speedometer of a car, however, is an instrument that “reinforces the notion that speed can be measured directly” (Lamon, 2012, p. 242),

Genesis of a concept is not its formalisation

Thompson and Thompson (1994) conducted a teaching experiment with a 10 year-old student to explore how she constructed the concept of speed as a rate through observing her play with a computer programme in which a rabbit and a turtle could be made to run at different speeds. The rabbit and/or turtle could be assigned different speeds, could be stopped at any time or distance, and could be made to run separately or together. They were to travel ‘over’ (to the right) and ‘back’ (to their starting position).

Figure 3.12 Over and Back user interface

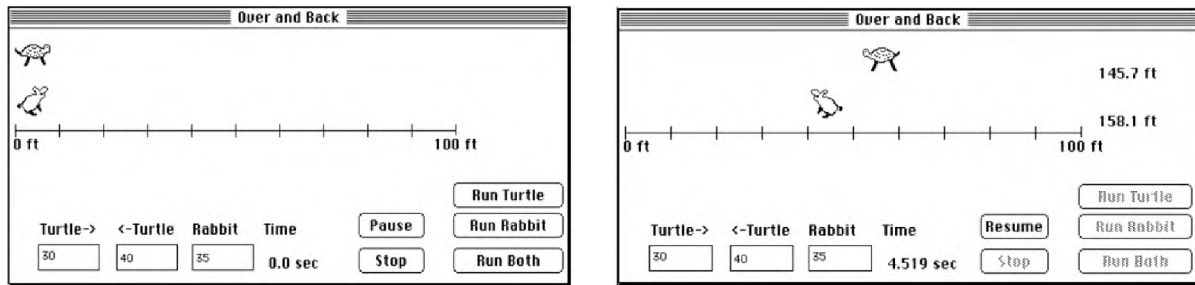

From Thompson & Thompson, 1994, p. 284

Thompson and Thompson (1994, p. 280) describe how they intended that the student construct her image of speed through this experiment:

1. Speed is a quantification of motion
2. Completed motion involves two complete quantities – distance travelled and amount of time required to travel that distance
3. There is a direct proportional relationship between distance travelled and the amount of time required to travel that distance
4. Speed as a quantification of completed motion is made by multiplicatively comparing distance travelled and amount of time required to go that distance

This practical game, involving the calculation and interpretation of speed, became central to instruction she received over 7 sessions. Each lesson was built around a problem to solve. Three examples of such problems included (Thompson & Thompson, 1994, p. 284):

1. Turtle is going over at 20 feet per second, coming back at 30 feet per second. How much time does he take?
2. Give Rabbit a speed that will make him go over and back in 7 seconds.
3. Turtle goes over at some speed and comes back at 70 feet per second. Rabbit goes over and back at 30 feet per second. Give Turtle a speed so that he and Rabbit will tie.

The computer game, and the associated questions, required the student to use a “dual measurement focus” (Thompson & Thompson, 1994, p. 285) by forcing a focus on time and distance, which provided a “foundation for [her] conceptualising constant speed as a rate” (p. 285). Her understanding of speed had developed from viewing the components of distance and

time as being dependent on one another, to accurately conceptualising them as independently covarying quantities (Thompson & Thompson, 1996).

In the 8th session she was presented with a problem involving flow rate when filling a swimming pool, and as she had constructed a conceptually sound understanding of rate through the lessons on speed, she was able to generalise the reasoning she applied in solving the speed problems, to solving the flow rate problems (Thompson & Thompson, 1994). Thompson and Thompson (1994) considered this to be evidence that she had developed a stable conceptualisation of rate through the lessons centred around the ‘over and back’ computer game focused on speed.

As Basson (2002) points out, where there are inadequacies in students’ conceptualisation of basic concepts, these are transferred to learning environments where these concepts are to be integrated to create more formalised structures, such as rate. Which... requires deep conceptual understanding of, not only the component concepts, but a “coherent conceptual model of [these] concepts” (Carrejo & Marshall, 2007, p. 55) and how they are connected. The formalisation of strongly embodied constructs like speed in the form of a rate, is complex and requires the relationship between the components to be revealed. As Thompson and Thompson (1996) demonstrated, when this is effectively done, the learning is sufficiently powerful to enable generalisation to other situations in which rate is a key concept.

In this research, students’ conceptualisation of rate is explored through an experiment involving the calculation of fluid volumetric flow rate. Fluid volumetric flow rate can be defined as the “volume of fluid flowing past a section per unit time” (Inamdar, 2012, p. 7). In this case, Thompson and Thompson’s (1994) list explaining the construct ‘speed’ as a rate can be adapted to read:

1. Flow rate is a quantification of the motion of a fluid
2. Completed motion involves two complete quantities – volume of fluid moving past a point and amount of time required for this volume of fluid to pass this point
3. There is a direct proportional relationship between volume of fluid flowing past a point and the amount of time required for the volume to flow past this point

4. Flow rate as a quantification of [static] completed motion is made by multiplicatively comparing volume of fluid flowing past a point and amount of time required for this volume to flow past this point

3.5 VYGOTSKY AND THE PROCESS OF CONCEPT FORMATION

Vygotsky's (1926/1986) theory emphasises the role of the social world in prompting the development of thinking, and it is here that his work differs most markedly from Piaget's. Where Piaget's theory is centred on individual processes as driving intellectual development with an influence from the environment, Vygotsky makes the following definitive statement: "thinking and behaviour of adolescents are prompted not from within but from without, by the social milieu" (p. 108). His position is that should the social milieu not make intellectual demands on the person, their thinking will not reach any higher stages.

The following discussion will outline Vygotsky's theory of the development of thinking in concepts, focusing on the role of words and the social world. Thereafter, the stages of this development will be described followed by a discussion of scientific and everyday concepts, as Vygotsky defines them. A further section considers the work of Margot Berger in applying Vygotsky's theory to the development of mathematical concepts.

Thereafter, the zone of proximal development [ZPD] as well as mediation, will be described.

3.5.1 The role of words in concept formation

Concept formation, to Vygotsky (1926/1986), involves the participation of all intellectual functions, but it is not these functions that undergo changes themselves. Rather, the use of signs or words "direct our mental operations, control their course, and channel them toward the solution of the problem confronting us" (p. 107). These intellectual functions, e.g. attention, perception, memory, or imagery, do not in themselves dramatically change. As Vygotsky (1926/1986) explains, once concept formation has begun they reappear "in an entirely different form" (p. 107).

None of this is possible, according to Vygotsky (1926/1986), without the use of words as signs, or "functional tools" (p. 107) that drive the formation of concepts. Development of the physiologically based intellectual processes, e.g. perception, does not lead to higher forms of intellectual ability. It is verbal thinking that is necessary for the qualitatively "radical change" (p. 109) that makes thinking in concepts possible.

Berger (2006) explains that children use words that they initially do not fully comprehend, but as they use it in communicating with adults, the meaning of the word and its associated concept evolves. In other words the concept “undergoes substantial development for the child as [they] use the word or sign in communication with more socialised others” (Berger, 2005, p. 155).

3.5.2 The process of concept formation

Vygotsky writes that “direct instruction in concepts is impossible [and leads to] mindless learning of words” (Vygotsky, 1987, p. 170). Concept formation, he explains, involves all basic intellectual functions (Vygotsky, 1926/1986, p. 106). He (1926/1986) distinguishes between three phases that lead to thinking in real concepts, arguing that the transition from one stage to the next is reliant on a child’s verbal interaction with adults. These stages are:

Syncretic heap

Objects are grouped together randomly and words do not hold stable meanings (Vygotsky, 1926/1986).

Thinking in complexes

Maximally similar objects are grouped in the child’s mind, no longer only based on their subjective ideas, but by “bonds actually existing between these objects” (p. 112). These bonds are concrete, however, and not yet abstract and logical as they would be in conceptual thinking (Vygotsky, 1926/1986).

Thinking in potential concepts

Objects are grouped together in the child’s mind based on a single attribute (Vygotsky, 1926/1986).

Vygotsky (1926/1986) describes thinking in potential concepts as developing parallel to thinking in complexes. There is a “bridge” (Vygotsky, 1926/1986, p. 119) that Vygotsky describes as linking thinking in complexes to the highest stage of concept formation. This link is a type of complex, called a pseudoconcept.

Pseudoconcepts phenotypically resemble thinking in concepts, in that children begin to communicate in a way that suggests mature conceptual thought. This is a “functional equivalence” (p. 121). As Vygotsky (1926/1986) explains, when children communicate verbally with adults, they acquire vocabulary as well as the “meaning a given word already has in the language of adults” (p. 120). On using these words, the mutual understanding that results

between adult and child would suggest that the achievement of conceptual thought has been reached. However, this mutual understanding remains largely coincidental. There is an intellectual and operational structural change that needs to happen in the child's thinking, as they use the word more frequently, in order to progress from thinking in complexes to thinking in real concepts (Vygotsky, 1926/1986).

When operating with pseudoconcepts, the child is operating conceptually without awareness of this. There is a resulting smooth, unobservable, transition from thinking in pseudoconcepts to thinking in concepts. Vygotsky (1926/1986) explains: "The concept-in-itself and the concept-for-others are developed in the child before the concept-for-myself. The concept-in-itself and the concept-for-others, which are already present in the pseudoconcept, are the genetic precondition for the development of real concepts" (p. 124).

3.5.3 Scientific and everyday concepts

Where Piaget (1962) writes of spontaneous and non-spontaneous concepts, Vygotsky (1987) differentiates between scientific and everyday concepts and argues that they develop differently. The broad defining characteristics of everyday concepts are that they develop without any formal instruction and are acquired informally by a child (Miller, 2011). Vygotsky (1987) uses the terms spontaneous and everyday interchangeably when speaking of these. Scientific concepts, however, are "real concepts [that are] distinct from less-developed formations, such as complexes and pseudoconcepts" (p. 98). It is important to note that by scientific concepts, Vygotsky is not speaking of the natural sciences, but of the social sciences (Miller, 2011). He refers to concepts such as 'exploitation' when providing examples of scientific concepts.

Vygotsky (1987) defines everyday concepts in the same manner as Piaget. His position is that these concepts are the result of a child's interaction with their immediate environment (Miller, 2011). His position is that after "a long period of development... the child can operate abstractly with [the] concept and move from the thing to the concept" (p. 125), however, it remains an everyday concept. Scientific concepts, however, follow the opposite path in their development. They are not encountered in the child's immediate environment but "as a mediated relationship to the object and follow the opposite path from the concept to thing" (p. 125).

Vygotsky (1987) provides the example of the concepts 'brother' and 'Archimedes' law' to illustrate the relationship of experience to scientific concepts. He argues that children would

find it easier to define Archimedes' Law, after it has been taught in school, than the concept of 'brother'. The concept of 'brother' is understood in an everyday form, "saturated with the child's personal experience" (Miller, 2011, p. 106). The development of these two types of concepts therefore follow different paths.

Another useful analogy Vygotsky (1987) in order to explain the relationship of everyday to scientific concepts and their influence on one another is the learning of a foreign language. Learning a foreign language, he explains, is different to learning one's home language, but success in learning a foreign language is largely dependent on proficiency in one's home language. In turn, the process of learning the foreign language allows the underlying form of the home language to become more explicit, thus contributing to further developing use of the home language. As Miller (2011) explains, "in the same way that the native language stands between the foreign language and the world of things, spontaneous concepts mediate between the conceptual systems in which scientific concepts are embedded" (p. 106). Scientific concepts, in the process of their formation and once formed, are "transferred structurally to the domain of everyday concepts, restructuring the everyday concept and changing its internal structure from above" (Vygotsky, 1987, p. 192).

3.5.4 Concept development in mathematics

In mathematics, Berger (2005) argues, the individual is required to construct the concept such that its meaning agrees with how it is used by the mathematics community. This construction happens as the individual communicates with learned others, for example, in interaction with a lecturer, a more knowledgeable peer or by the use of a textbook. These mathematical concepts are thus socially integrated (Berger, 2005).

Berger (2006) reports on her observations of university students encountering mathematical signs with which they were previously unfamiliar. These students worked as if they were proceeding through preconceptual stages as would a child encountering words for the first time. She noticed that students were making use of heap or complex thinking as they worked with these new ideas and signs before conceptual thinking was possible.

In her own practice, Berger (2006) observed that students were initially making idiosyncratic uses of the signs and operated in a manner akin to the heap and complex stages. Non-logical activities, such as imitation and manipulations, were used to solve problems using these mathematical signs. The students had varying levels of success with these strategies, but,

Berger (2006) argues that this “preconceptual thinking is a necessary part of successful mathematical concept construction” (p. 17). She elaborates:

...[it] is not *how* [emphasis in original] the student uses the signs but rather *that* [emphasis in original] [they] use the signs. Through this use, the student gains access to the ‘new’ mathematical object and is able to communicate (to better or worse effect) about it. And...it is this communication with more knowledgeable others which enables the development of a personally meaningful concept whose use is congruent with its use by the wider mathematical community (p. 17).

Therefore, despite the dismissal by many mathematics educators of activities that allow functional, idiosyncratic uses of a sign, Berger (2006) argues that it is essential if conceptual thinking is to be achieved.

3.5.5 Signs and tools

The notion of ‘signs’ and their role in concept formation has already been discussed, but signs can also be understood as an “auxiliary means of solving a given psychological problem” (Vygotsky, 1978, p. 52). For example, words can be used to assist someone in remembering something and thus the “sign acts as an instrument of psychological activity” (p. 52). It is an internal activity. Tools, on the other hand, are also an auxiliary means by which problems can be solved, but are focused outwards, on the object of activity. Their use is a “means by which human external activity is aimed at mastering, or triumphing over, nature” (p. 55). Daniels (2005), in his *Introduction to Vygotsky*, takes care to point out that Vygotsky (1978) did not imply that human behaviour is controlled by external forces. The symbolic systems that come to form psychological signs, as well as the physical tools used in activity, are only useful because of the meaning the individual has come to ascribe to them. In other words, external operations have been “internal[ly] reconstructed” (Vygotsky, 1978, p. 56).

Wertsch (2007), writing of Vygotsky’s notions of signs and tools, explains that our actions in the world are never direct, they are always mediated by these. The figure below is used by Vygotsky (1978) to represent the relationship between signs and tools, in which “each concept is subsumed under the more general concept of indirect (mediated) activity” (p. 54). Vygotsky (1978) regarded as “higher psychological function or higher behaviour” (p. 55) the combined use of sign and tool.

Figure 3.13 Sign and tool mediation

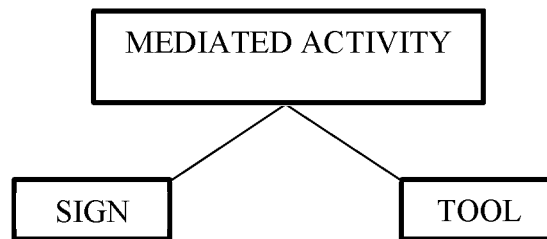

(Vygotsky, 1978, p. 54)

3.5.6 The Zone of Proximal Development

Vygotsky (1978, p. 84) points out that “any learning a child encounters in school always has a previous history”. He proposed that a student who is unable to complete a task successfully may well be able to complete it with some assistance, indicating a potential for learning. He calls this the zone of proximal development [ZPD], which is “the distance between the actual developmental level as determined by independent problem solving and the level of potential development as determined through problem solving under adult guidance or in collaboration with more capable peers” (Vygotsky, 1978, p. 86).

Unlike Piaget (1962), who contends that maturation is a necessary precondition for learning, Vygotsky (1978) argues that “the developmental processes lag behind the learning processes [and] this sequence then results in zones of proximal development” (p. 90). Activities and experiences that can be described as within a child’s ZPD would be those that are “challenging but attainable” (Hedges, 2012, p. 146). It is a “zone where children’s everyday understandings interact with conceptual knowledge provided by mediators of learning, such as teachers” (p. 146). Engagement in the activities in this zone does not require a particular developmental level to have been attained, in fact, Vygotsky (1978) argues that engagement in such activities can urge mental development forward.

Vygotsky’s (1978) notion of the ZPD therefore indicates that conceptualisations can be either stable or emerging. Stable conceptualisation or understanding would be present for a student able to complete a task requiring this conceptual knowledge independently, while conceptual understanding could be described as emerging for a student only able to do so with assistance. The ZPD in this way provides “a tool through which the internal course of development can be understood” (p. 87).

3.5.7 A note on mediation

The term ‘mediation’ is one that appears in Vygotsky’s (1978) explanation of signs and tools as subsumed under the category of mediated action. It also appears in discussions of the ZPD (e.g. Hedges, 2012) to describe the person whose conceptual knowledge allows them to guide children in their completion of tasks within their ZPD.

Wertsch (2007) applies his understanding of the Vygotskian term ‘mediation’ to encompass two concepts of his own: implicit and explicit mediation. He defines explicit mediation as “an individual, or another person who is directing this individual, overtly and intentionally introduc[ing] a ‘stimulus means’ into an ongoing stream of activity” (p. 180). Implicit mediation is taken to be the opposite in that it is “less obvious and therefore more difficult to detect” (p. 180). In a measurement situation, an example of an explicit mediational means would be the use of a calculator in computing the area of a triangle, whereas the use of terminology such as ‘height’, ‘base’ or ‘hypotenuse’ would represent implicit mediational means (Miller, 2011), in other words, differentiating between tools and signs. Wertsch (2007) makes a careful argument for these concepts but is deliberate to point out that these are based on his readings of Vygotsky. Miller (2011) is critical of this reading and argues that these two contrasting meanings of mediation are not present in Vygotsky’s text.

In this research, the terms implicit and explicit mediation are used, although not in the sense that Wertsch (2007) uses them. In addition, no claim is made that the use of these terms can be interpreted from any of Vygotsky’s original texts. The terms are used for their utility in describing the two broad types of ‘mediation’ that will be provided by the interviewer in the task-based interviews. The mediation provided is classified on a continuum from most implicit to most explicit depending on the degree of assistance it is considered to provide to the student as they engage in the task. This is discussed and described in full in Chapter 4.

3.5.8 Conceptualisation of the act of measuring for this research

As mentioned in the introduction to this chapter, it is the psychological concepts that Vygotsky (1978) offers that are applied in this research for their utility in describing the act of measurement. Both Vygotsky and Piaget, in their theories on the development of thinking in concepts, frame this development in the context of a child’s interaction with their physical and social environment.

The student, as they interact with a measurement task, may be conceptualised as comprising a mental self, which relates to the constructed measurement conceptualisations, and a physical self whose actions in the environment can be observed. The actions of the physical self are led by these mental conceptualisations, but this interaction in the physical and social world in turn contributes to shaping the intrapersonal mental conceptualisations, as is proposed by Piaget (1964) and Vygotsky (1978).

Together, these two comprise what can be referred to as the embodied subject. This subject cannot be fully known, however its actions can be observed. The embodied subject engages in the activity of measuring the object or phenomenon as mediated by signs and tools. This is represented in Figure 3.14.

Figure 3.14 The individual engaging in measuring activity

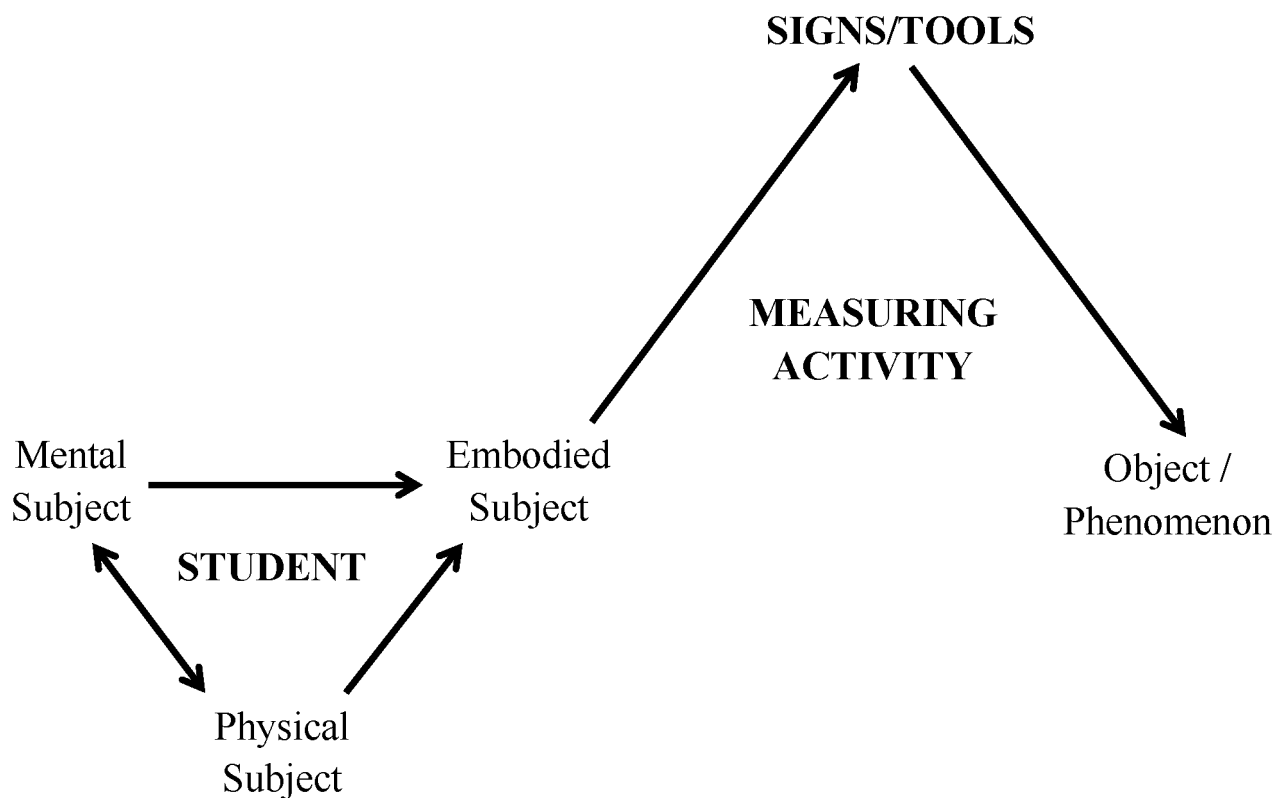

This view of the individual as they engage in the measurement task is key to the understanding of the mediated measurement interaction proposed at the conclusion of this chapter.

3.6 DYNAMIC ASSESSMENT

In assessing the prior knowledge of measurement and existing measurement proficiency of adult students, it is necessary to structure that assessment in such a way that it is not only those stable understandings of measurement that are accessed, but also those that are in the process of emerging. Dynamic, rather than static, assessment offers a means of revealing both developed and developing conceptualisations.

Static assessment captures only what has already been learned, but it is possible that this is a reflection rather of an individual's background (de Beer, 2006). In contexts where there are large disparities in the quality of prior education, dynamic assessment is a "more compassionate, fair and equitable" (p. 9) means of assessment.

3.6.1 What is dynamic assessment?

It involves the integration of assessment and instruction to include forms of mediation that promote the students' development, while allowing the assessor insight into both their current state of development and their potential to learn (Zhang, 2010). It rests on Vygotsky's (1978) notion of the ZPD, which is arguably the first theory of dynamic assessment (de Beer, 2006).

Vygotsky (1978) explained that the actual developmental level, which would be captured by a static assessment, "characterizes mental development retrospectively, while the zone of proximal development characterizes mental development prospectively" (p. 88). What the ZPD can offer educators is a "tool through which the internal course of development can be understood" (p. 88), thus allowing a view of achieved concepts as well as those in the process of maturation and development (Vygotsky, 1978).

3.6.2 Approaches to dynamic assessment

Dynamic assessment traditionally takes a test-teach-retest interventionist approach (de Beer, 2006). In this model, students complete a static pre-test that is completed without assistance, and after an assisted learning experience they complete a similar post-test (Fuchs, Compton, Fuchs, Hollenbeck, Hamlett & Seethaler, 2011). The post-test gives an indication of the individual's potential to learn.

Poehner and van Compernelle (2011) argue, however, that the full potential of dynamic assessment is realised through "collective, transformative activity undertaken with learners"

(p. 183). Such interactionist dynamic assessments are characterised by mediation that is negotiated with the individual and adjusted accordingly rather than rigidly prefabricated clues and hints (Poehner & Lantolf, 2010). What is measured becomes “the amount of scaffolding required during the assisted phase of assessment to reach criterion performance” (Fuchs et al., 2011, p. 374).

This collaborative framing of dynamic assessment foregrounds the engagement with the assessment task, while the assessor works with the learner on this task. Framed in this way, it is possible to identify “kinds of mediation to which learners are responsive during task completion” (Poehner & van Compernelle, 2011, p. 184). Mediation therefore has a dual function in this case: it “offers affordances to which learners may respond in a variety of ways, and careful observation of these responses forms part of the diagnosis of their development, indicating how near they are to being able to function more independently” (p. 184). Diagnosis and enrichment can therefore co-occur (Poehner & van Compernelle, 2008).

As Lantolf and Poehner (2011) explain, shifting the view slightly to focus on responsiveness to mediation, rather than performance in a post-test, provides richer evidence of development. It thus becomes possible to obtain a more nuanced view of the students’ measurement understanding. For example, a student who is able to complete a task after only implicit mediation has more “control over what is to be learned and is therefore further along the way towards autonomous performance” (p. 20) than a student who requires more explicit mediation. An example of implicit mediation might be a prompt as simple as a pause, while correction of an error would constitute explicit mediation (Lantolf & Poehner, 2011). By focussing on the degree and type of mediation required, it would be possible to distinguish between individuals at different stages in the emergence of measurement understanding.

3.6.3 Problems with quantification and the solutions offered by computer-based tests

The practical value of dynamic assessment in a more widespread and general manner has been called into question (de Beer, 2006). The difficulty in using dynamic assessment techniques as a diagnostic tool is that a consistent means of quantifying learning potential has not been established (de Beer, 2006). In addition, very little research has been published regarding its validity and reliability, without which dynamic testing cannot be transformed into “robust psychological diagnostic tools” (p. 9). Some of the problems, de Beer (2006) explains, include: “subjective scoring of some procedures; problems with measurement accuracy of...the

difference or improvement scores, the lack of standardisation, which limits generalisation and the practice effect if the same instrument is used in the pre-test and in the post-test” (p. 11).

There has been some success in overcoming these with the use of computer-based tools. The Learning Potential Computerised Adaptive Test [LPCAT] (de Beer, 2000), developed in South Africa, is one such example. This programme measures an individual’s ZPD based on the difference in the scores on a pre-test and post-test (de Beer, 2000). The LPCAT interactively selects items which are at the correct level for the student. It adjusts the level of difficulty as the student responds either correctly or incorrectly to the items.

This addresses all of the problems listed by de Beer (2006), but it can be questioned whether this is a valid measurement of prior knowledge and learning potential. The reported result, if it is to allow fair comparison across individuals, is more complex than a simple difference score, and so it is also necessary to combine this score with the individual’s pre-test and post-test score. A low difference score may be achieved by an individual who has already achieved a high score in the pre-test. Their future projected ability level would be high, but their difference score alone would seem to indicate a low learning potential.

Another example of such a computer programme is the Graduated Prompting Assessment Module [GPAM] used by Wang (2011) in the remedial teaching of high school mathematics learners. In this case, dynamic assessment was not only used as a means of assessing learners, but as a tool for teaching. Learners were required to respond to test items, and if they were unable to respond correctly, instructional prompts were provided in a graded manner until the learner was able to respond correctly (Wang, 2011). The system “directly interacts with learners and provides them with timely feedback carrying instructional messages to facilitate learning” (p. 1063). Feedback provided in this way is individualised and because it is a prompt rather than explicit instruction, learners correct their own mistakes and resolve misconceptions for themselves (Wang, 2011).

Wang (2011) was able to show that using the GPAM was significantly more effective than traditional remedial mathematics teaching, and “not only for those [learners] most lacking in different types of mathematical problem-solving knowledge but also all the other students” (p. 1062). Not only does a programme of this nature produce assessment results that are comparable across students, as does the LPCAT, but the graduated instructional prompting approach also provided a powerful learning experience for the learners.

3.6.4 The application of dynamic assessment in this research

In this research, generalisability was not being sought. It focused on a relatively small group of students in an attempt to explore, in as much depth and detail as possible, their prior knowledge and existing measurement conceptualisations. The complexity of this task required an instrument with flexibility that allowed for the fair assessment of an extremely diverse group of students and a sensitivity that allowed for adjustment depending on the needs of each student as they engaged in the task. In-built subjectivity is necessary in such a case. Each student, as they engage in a task, can be expected to have different needs and will demonstrate different prior knowledge profiles. A standardised dynamic assessment does not capture these subtleties.

While this subjectivity has value, it remains the case that the results need to be valid and reliable within the study. In order to ensure this, the types of mediation and the way in which the mediator would interact with the student was carefully planned. A full description of the process of designing the interviews is provided in Chapter 4. The figure below provides an illustration of the positioning of the student and mediator relative to the task:

Figure 3.15 Interaction with the mediator in the mediated measurement task

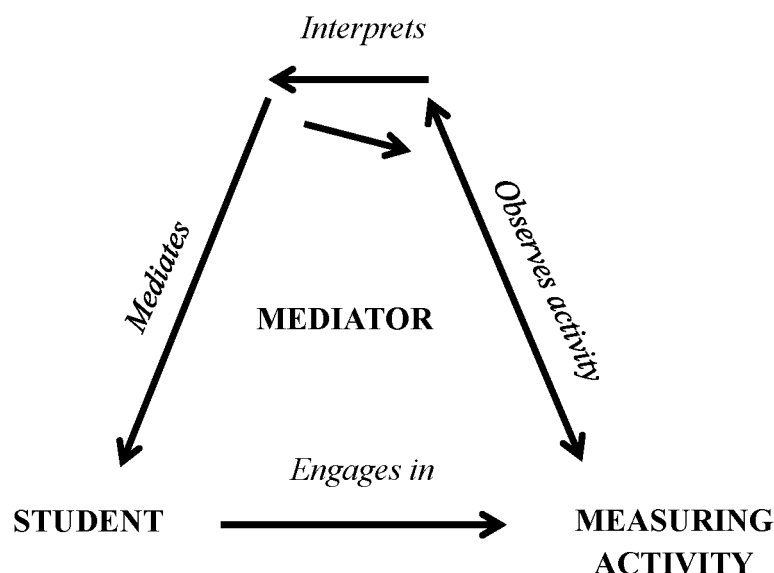

The mediator is depicted as central as they control the task situation and their decisions about when and how to mediate influence the course of the activity. As the student engages in the measurement activity, the mediator observes and interprets the actions of the student. The student continues engaging in the activity independently until the mediator interprets their

actions as indicating that they do not know how to proceed, or that they are veering off a path that could lead to the solution. At this point, the mediator provides a form of mediation that can assist the student to proceed in the task.

This form of mediation is carefully chosen. The most implicit form of mediation is provided first. If the student remains unable to move forward, increasingly explicit forms of mediation are provided until the student is able to continue engaging in the activity. The more explicit the required mediation, and the more moments in which mediation is required, is understood as providing an indication that the prior knowledge required for the task is lacking, or still emerging.

In this research, mediation was provided at the level of signs through verbal interaction with the mediator. The mediator did not engage in the measurement with the student, hence there is no link between the mediator and the actual measurement task.

3.7 RECONSIDERING THE USE OF PIAGET AND VYGOTSKY

In the introduction to this chapter, it was pointed out that the theories of both Piaget and Vygotsky find their application in this study, in various forms. The broad overlap of their theories is that both view a learner as actively constructing knowledge rather than passively receiving it (Rowlands & Carson, 2001). From there, their theories diverge to provide explanations of learning that can be considered as parallel, rather than oppositional. The following three central ideas represent important differences between their theories (S. Lerman, personal communication, Jan 18, 2017):

Table 3.3 Key differences between the theories of Piaget and Vygotsky

Piaget	Vygotsky
Development leads to learning	Learning leads to development
Knowledge proceeds from the concrete to the abstract	Knowledge proceeds through the ascent from the abstract to the concrete
The cognising individual is at the centre of the learning process	Mediation and the mediators are central

If the aim of the study was to explore the process of internalisation, these would represent incommensurable differences. The research questions, however, seek to uncover the product

of internalisation – the existing measurement conceptualisations of the students – and not to uncover the process by which these were, or can be, acquired.

Tools have been designed, utilising these theories, with the specific purpose of providing a snapshot of these conceptualisations. None of the three core ideas of either theorist, as summarised in Table 3.3, are applied in the analysis of the data. This is discussed in more detail in Chapter 4.

3.8 MEDIATED MEASUREMENT INTERACTION

The model of the dynamic assessment interview situation (Figure 3.15), and the model of the student as they engage in measurement activity (Figure 3.14) which are proposed here, together form a model which functions to define mediated measurement interaction in this study. Figure 3.16 below outlines this model (also provided as Appendix J):

Figure 3.16 The mediated measurement interaction model

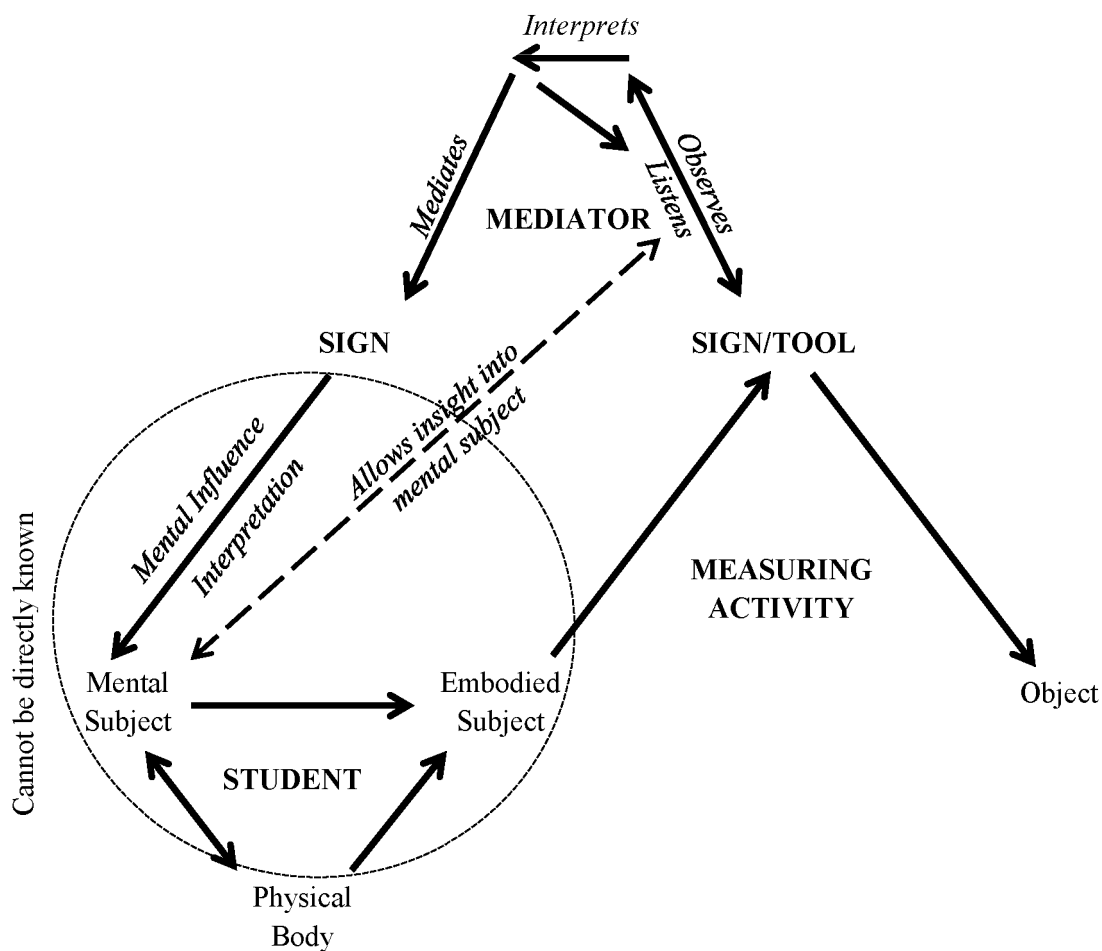

The position of the mediator in relation to the task and the student has already been presented, but the process of this mediation, and the potential insight it provides requires expansion. As mentioned, the mediator in this interview situation is not involved in completing the measurement activity itself. The mediation takes the form of signs, in the form of verbal interactions with the student. In order for the student to make sense of the mediation provided in relation to the measuring activity, the sign needs to be interpreted. This interpretation influences the mental subject in terms of deciding how to adjust their approach and engage further in the activity.

While the mental subject cannot be directly known, and therefore the existing measurement conceptualisations cannot be directly known, careful observation of the student as they work, and careful observation of their responsiveness to the mediation provided can allow a degree of insight into this. A student's actions after sign mediation is provided can provide an indication of how that student has interpreted the sign, and this therefore provides a view into the existing measurement conceptualisation of the student.

3.9 SUMMARY

In this chapter, the theories guiding this research have been outlined and discussed for their relevance in answering the research questions. The theories of Piaget (1964) and Vygotsky (1926/1986; 1978) guided the structure of the chapter. Piaget, and neo-Piagetian David Tall, informed the view of mathematical understanding and measurement, while Vygotsky's work provided a frame within which to view mediated measurement interaction.

Tall's (2013b) theory about the development of mathematical thinking, and the three worlds of mathematics, provides a structure that allows the classification of the demands of various measurement tasks, as well as progression in measurement learning according to South African curricula. A detailed discussion followed in which measurement and related concepts were defined and the domains of measurement relevant to this research were explored.

Concepts derived from Vygotsky (1978) were synthesised to form a model that is used in this research to structure the methodology and allow insight into students' measurement conceptualisation.

CHAPTER 4

METHODOLOGY

4.1 INTRODUCTION

Cohen, Manion and Morrison (2011) explain that the design and planning of any research project centres on the purpose of the research. It is the research goal and questions that should guide the design of the research and the chosen methodology, and this requires careful consideration (Cohen et al., 2011).

This chapter therefore opens with an explicit statement of the goals and questions to be addressed in this research. Thereafter, the research approach will be outlined. First the paradigm, ontology, epistemology and methodology will be discussed. Thereafter, the details of the design will be described, including site selection and participants as well as the methods employed. Following this, the data analysis approach and method will be outlined.

It is also crucial to consider issues of validity and reliability, as well as ethical concerns related to the research. The chapter closes with a discussion of these.

4.2 RESEARCH QUESTIONS

The goal of this research is to explore the prior conceptual understanding of first year National Certificate (Vocational) Engineering students. The specific aims and questions are as stated below:

Research aims

- To explore the stable measurement conceptualisation of the students as evident in their engagement with mediated measurement tasks
- To explore the partial or emerging measurement conceptualisation of the students as evident in their engagement with mediated measurement tasks
- To explore where the break between what is needed as stable measurement conceptualisations, and what is possessed as emergent measurement conceptualisations, occurs

Research questions

1. What stable measurement conceptualisations are evident in students' engagement with mediated measurement tasks?
2. What partial or emerging measurement conceptualisations are evident in students' engagement with mediated measurement tasks?
3. Therefore, based on the analysis of stability and emergence as evident in students' engagement in mediated measurement tasks, where does the break between what is needed as stable conceptualisations, and what is present as emergent conceptualisations, occur?

4.3 RESEARCH APPROACH

This research is an exploratory, qualitative case study that takes an interpretive position and is located in a constructivist paradigm. In this section, the philosophical underpinnings of the research will be outlined in a discussion of the chosen paradigm and an explanation of the ontological, epistemological and methodological positions the research takes.

Thereafter, the qualitative and exploratory nature of the research will be explained, and an argument for the case study design will be made. The case under investigation will also be explicitly delineated and the role and positioning of the researcher described.

4.3.1 Research paradigm

This research takes an interpretivist position within the paradigm of constructivism. The term 'constructivism' encompasses a wide variety of possible positions, of which this research has selected a very specific stance. This is described in the following section.

4.3.1.1 Interpretivism as a research position

Bhattacharya (2008) defines interpretivism as a practice or framework that encompasses a set of paradigms, among them constructivism. Tobin (2000, p. 487) similarly explains that interpretivism is "an umbrella term used to describe studies that endeavour to understand a community in terms of the actions and interactions of the participants". This research takes interpretivism as its overarching frame, within which the chosen paradigm of constructivism is defined.

As Tobin (2000) further points out, interpretive researchers engage in systematic activity that is focused on efforts to understand interactions between participants in a study. While Tobin

writes in particular of the interactions between participants, Cohen et al. (2011) explain that interpretive research “begin[s] with individuals and set[s] out to understand their interpretations of the world around them” (p. 60).

In this research, the interaction in question is that between the individual student and the measurement task with which they are engaged, as well as the interaction between students and the mediator during the task-based interviews. The primary understanding sought is how these individuals interpret the world around them in terms of their conceptual engagement in tasks requiring the measurement of the attributes of real-world objects.

4.3.1.2 Constructivism

There are many variants of constructivism, and this study needs to position itself firmly in terms of the particular constructivist position it takes. In the following sections the key issues of constructivism will be outlined and an argument will be made for the particular theoretical stance, within the paradigm of constructivism. This chosen stance holds the most pragmatic value in seeking answers to the research questions.

Where there is consensus among constructivists is in the notion that “the learner is not a passive recipient of knowledge but that knowledge is constructed by the learner in some way” (Rowlands & Carson, 2001, p. 1) as well as the view that this knowledge is actively constructed in response to social and physical interactions (Golafshani, 2003). There is agreement that there is cognitive potential present at birth, but knowledge and the methods used to acquire knowledge, are constructed through interactions between human beings in our “multiple and diverse realities” (p. 603) within our social and physical contexts. This study is broadly informed by this view of the individual student.

These descriptions of constructivism are, however, an “oversimple gloss” (Phillips, 1995, p. 5) on the complex nature of constructivism, and there is “an enormous number of authors, spanning a broad philosophical or theoretical spectrum” (p. 6) that would call themselves ‘constructivist’. Phillips (1995) criticises constructivism for its “rampant sectarianism” (p. 5) regarding positions taken as to what exactly is constructed, and how it is constructed. He also writes that in many constructivist texts the reader is left to infer for themselves what position the author is taking (Phillips, 1995).

Phillips (1995) provides a description of three continua, representing key issues, along which, he argues, the various forms or sects of constructivism would position themselves. Each continuum will be discussed in order to make explicit the particular constructivist stance taken in this research.

These continua are:

1. Individual psychology versus public discipline

Is the researcher concerned with “how the individual learner constructs knowledge in his/her own cognitive apparatus... [o]r with the construction of human knowledge in general” (p. 7)?

2. Humans the creator versus nature the instructor

Is the construction of knowledge a process that is “influenced chiefly by the minds or creative intelligence of the knower or knowers, together with socio-political factors that are present when the knowers interact...[or] is the knowledge imposed from the outside...[with] nature serv[ing] as an instructor or...template” (p. 7)?

3. Individual cognition versus social and political processes

Is the activity of knowledge construction “described in terms of individual cognition or else in terms of social and political processes, or...in terms of both” (p. 8)?

Individual psychology versus public discipline

The focus of this study is on individual students as they engage in measurement tasks. Observations of the students as they perform these tasks are used to infer the measurement conceptualisation of the students in their own minds. Measurement as a knowledge domain is a public discipline, but this research is not concerned with the construction of human knowledge of measurement in general. It is concerned with the individual’s subjective view of this objective public discipline and is therefore positioned at the extreme end of this continuum: ‘individual psychology’.

Humans the creators versus nature the instructor

Phillips (1995) provides the figure below in order to explain his second continuum, in particular, to differentiate two different meanings of the ‘humans the creators’ category. Humans are creators when individually constructing knowledge within their own minds. Humans are also creators in terms of the socio-political construction of disciplinary bodies of

knowledge (Phillips, 1995). One can therefore take a ‘humans as creators’ view and still maintain a focus on the cognition of an individual student. This position does not imply that the constructivist stance should be ‘public discipline’ on the first continuum, and/or ‘social and political processes’ on the third continuum if the research is to be paradigmatically coherent.

Figure 4.1 Complexities of the second continuum

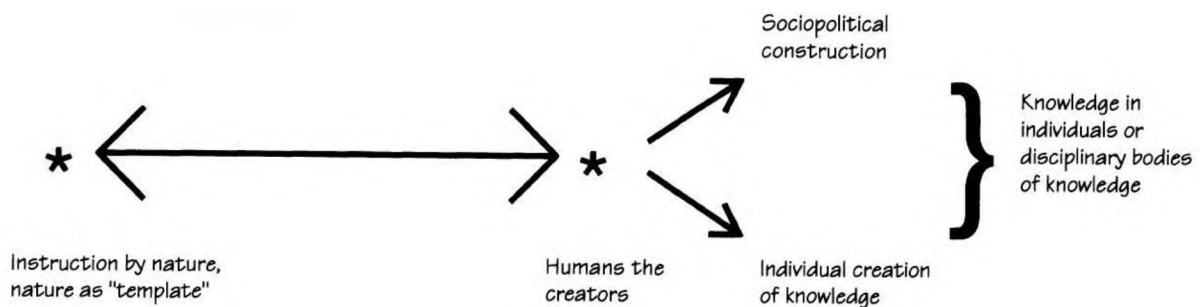

(Phillips, 1995, p. 8)

In its perspective on the mathematical domain of measurement, which is a public discipline, this particular research is positioned between the two poles of this continuum. In the case of practical measuring activities, the attributes of objects (e.g. area or volume) exist independent of the knower. They are “tangible and directly experienced quantities... and remain strongly connected to the measurer’s physical world” (Smith et al., 2011, p. 618). The public discipline itself links to the position of ‘nature the instructor’.

The material tools used to measure these quantities; the language used to describe them; the symbolic conventions used to represent them and the computational strategies used to calculate them, however, can all be viewed as social constructions. They are “essentially social agreements... and this philosophical position implicates the social” (Ernest, 1998, p. 134). Humans are therefore the creators of these.

When considering the mathematical domain of measurement, therefore, nature is an instructor in so far as the attributes of the objects to be measured exist independent of the student whose task it is to measure it. The tools and signs used by these students in the activity of measurement, however, reflect the cognitive work of scholars over generations (Phillips, 1995), and are thus viewed to be the creation of humans.

Research Questions 1 and 2 ask about students’ existing measurement conceptualisations. The position this research takes regarding students’ constructed conceptualisation of measurement

is that of ‘humans as creators’. The individual student is born with “some cognitive or epistemological equipment or potentialities...but by and large human knowledge [is] constructed”.

Research Question 3 asks where the break between what students need as stable measurement conceptualisations, but rather possess as emerging measurement conceptualisations, might occur. When considering the process of students’ construction of their measurement conceptualisations, it is the perspective of this research that these conceptualisations have been shaped by both students’ interaction with their physical world, and by their interaction with measurement tools, domain-specific language, symbolic conventions and computational strategies when these are introduced.

Their learning is therefore due in part to informal learning, but is also due to the public domain disciplinary knowledge (the human creation) as it is introduced (see Section 3.4). Measurement always has a link to the physical world, but students’ interaction with the humanly created disciplinary knowledge plays a core role in this learning. As the mathematical domain of measurement is taken to involve both ‘nature as instructor’ and ‘human as creator’, answering Question 3 will similarly involve consideration of both, but with an emphasis on the conceptually accurate public domain knowledge that these vocational students are expected to have constructed.

Individual cognition versus social and political processes

Figure 4.1, provided by Phillips (1995) to explain his second continuum, contains within it a reference to the third. The distinction made within ‘humans as creators’, between socio-political construction and individual creation of knowledge, is the distinction made here.

In Chapter 2, the South African schooling context and the TVET college context were extensively described, and it is without question that social and political influences within these contexts have had an influence on the participating students’ mathematics education and thereby the degree to which they were able to construct conceptually stable and accurate mental representations of measurement concepts.

This research does not, however, seek to explore the influence of social, political and cultural processes on knowledge construction. The focus is specifically on students’ individual cognition. It takes the view that although social and political influences exist, it is nevertheless

the individual cognitive activity of the student that results in their measurement conceptualisation. Social and political influences may strongly impact on the individual's environment within which the individual interacts, but it is the individual's own mental processes that are involved in actual construction of their mental representations of measurement concepts based on this situation. It is this individual construction process that is the focus of this research.

The perspective taken in seeking answers to Questions 1 and 2 is that the measurement conceptualisations are cognitive 'human creations' of each individual student. Question 3 asks about how best to facilitate students' creation of accurate measurement conceptualisation. As knowledge construction is described in terms of individual cognition and not social and political processes in this research, this also positions the research with regard to Question 3 at 'individual cognition' on this continuum.

Summary

The constructivist analytical position taken for the purpose of this research is that the learning of measurement concepts involves active, individual, cognitive construction. Learning "proceed[s] from an individual's uniquely and individually constructed interpretation of [the] world" (Schuh & Barab, 2008, p. 78).

As a basic summary, Figures 4.2 – 4.4 provide the constructivist positioning of the study on Phillips' (1995) three continua.

On continuum 1, the research selects as its focus on the individual psychology of the student.

Figure 4.2 Continuum 1: Individual psychology vs Public discipline

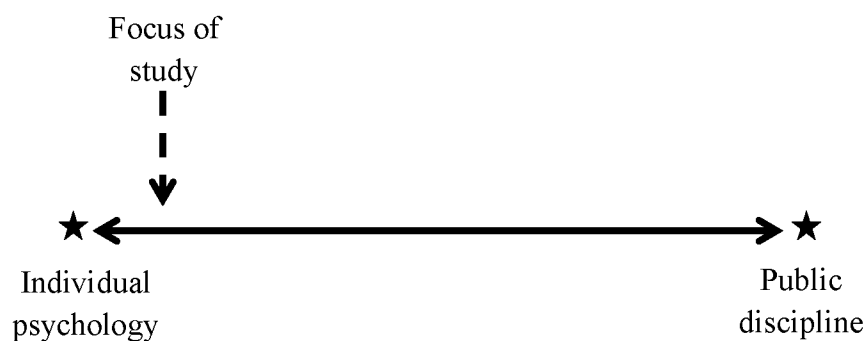

On continuum 2, the public discipline of measurement, is viewed to have been influenced by both 'nature as instructor' and 'humans as creators'

Each research question, however, is directed at understanding students' individual construction of measurement concepts and these individual constructions are cognitive human creations.

Figure 4.3 Continuum 2: Nature as instructor vs Humans as creators

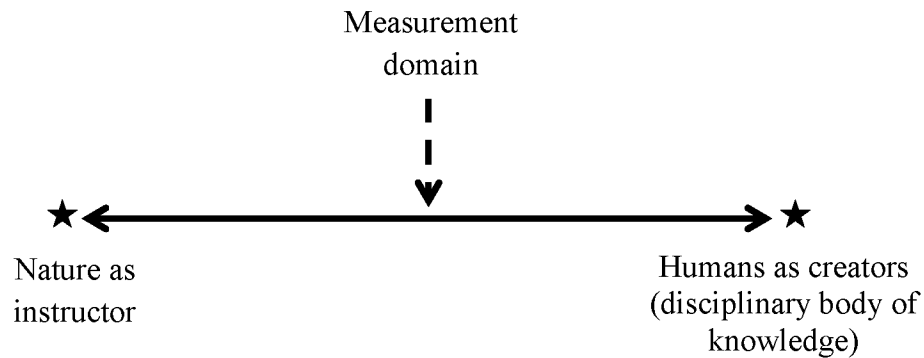

On continuum 3, the research uses the perspective of measurement knowledge as cognitively constructed by the individual student.

Figure 4.4 Continuum 3: Individual cognition vs Social and political processes

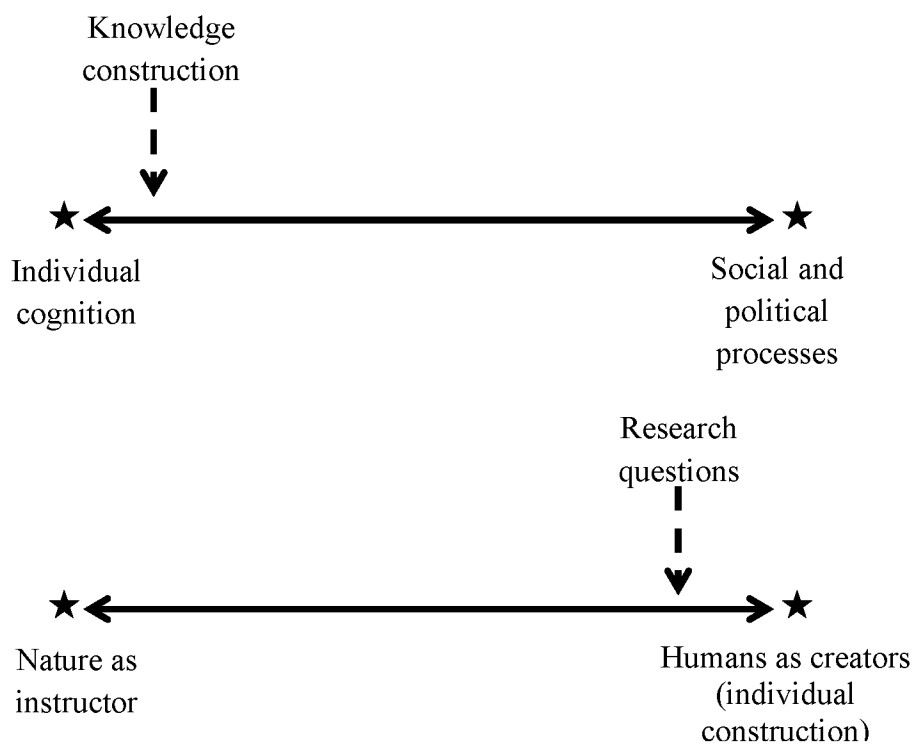

4.3.2 Ontology, epistemology and methodology

In the following section, the general ontological and epistemological position of the research, as well as how they relate to the methodological position, will be outlined. The ontological

view is realist, the epistemological view is constructivist and the methodology is interpretivist. In keeping with the interpretivist methodology, the overall approach to the research is qualitative.

4.3.2.1 Realism as ontology

This research adopts a realist ontology. Realism is defined by Schuh and Barab (2008) as an ontological view that “there is some sort of reality that is separate from the mind” (p.68).

This is not incommensurable with the chosen constructivist paradigm. Maton (2014) writes that knowledge and reality are frequently confused in discussions of ontology and epistemology. The realist ontological view that there is a real world does not preclude the claim that knowledge is constructed (Maton, 2014) by the individual.

4.3.2.2 Constructivist epistemology

This research claims a constructivist epistemology. That there are many variants of constructivism has already been explored, but there is an epistemological core that can be considered to run through these. This core is that “each individual mentally constructs the world of experience through cognitive processes” (Young & Collin, 2004, p. 375). As Young and Collin (2004) further explain “the world cannot be known directly, but rather by the construction imposed on it by the mind” (p. 375).

The interpretation of the data will remain a personal interpretation of the researcher, based on internal cognitive processes, given the constructivist epistemology (Stake, 2010). Measures have been taken in the design of the research to enhance the validity and reliability of these interpretations (see Section 4.6).

4.3.2.3 Interpretivist methodology

Methodology is defined here as the overall approach to the research, rather than the specific methods for data collection (MacKenzie & Knipe, 2006; Schensul, 2008). It forms the frame of reference for the research design and is therefore strongly linked to the chosen research paradigm (MacKenzie and Knipe, 2006) and underlying epistemology. The methodology in this research is accordingly interpretivist.

Schensul (2008) writes that interpretivist methodologies “focus on the meanings attributed to events, places, behaviours and interactions, people, and artefacts” (p. 517). This is in keeping with the focus of this research, which lies in interpreting students’ behaviours and interactions as they engage in measurement-related tasks in order to discover their constructed meanings of measurement concepts. Just as constructivism is a paradigm that is encompassed by interpretivism, so is the focus on the constructions of the students in the research questions commensurable with an interpretivist methodology.

Schensul (2008) further explains that the researcher’s own involvement in the research is key. In an interpretivist study, meaning emerges “both through interaction among [the] participants and between the researcher and the participants” (p. 517). It is for this reason that part of the design of the task-based interviews, the core data collection method in this research, the researcher took the role of interviewer.

4.3.2.4 Qualitative approach

This research takes a qualitative approach to its design for its value in answering the research questions. This approach is in keeping with the interpretivist and constructivist paradigms within which it is situated as it is predominantly qualitative methods used in studies of that nature (MacKenzie & Knipe, 2006).

According to Stake (2010), qualitative research is often defined as being interpretive research. Mardis, Hoffman and Rich (2008), however, write that the term ‘qualitative research’ is used in a variety of ways that are not always equivalent. Some of the terms used to define it include “method, methodology, tradition, framework and paradigm” (p. 174), with little consistency between authors. For the purposes of this research, it is described as an approach that has informed the design of the study

Qualitative research is frequently defined negatively, that it is ‘not quantitative’, rather than providing an explanation of what it is (Mardis et al., 2008). Denzin and Lincoln (2005) provide a more substantial definition:

... qualitative research is a situated activity that locates the observer in the world. It consists of a set of interpretive, material practices that make the world visible. These practices transform the world... attempting to make sense of, or interpret, phenomena in terms of the meanings people bring to them (p. 3)

The research questions require data to be drawn from students' engagement in measurement tasks. It is not the final result of their efforts that is sought, but evidence from their engagement as they work to arrive at their solutions. What is needed is an in-depth analysis the detailed text and image data that a qualitative approach will emphasise (Cresswell, 2014) and descriptions of "the action, the dialogue, the people... and the passage of time" (Stake, 2010, p. 48). It is this qualitative data that provides "richness and colour" (Wellington, 2014, p. 29) to the descriptions and therefore greater depth to the possible interpretations.

4.3.3 Exploratory research

As has been established, the area of research is one about which there is relatively little known, therefore the nature of the research is exploratory. Stebbins (2007) explains that "when researchers possess little or no scientific [knowledge] about the group, process, activity or situation they want to examine" (p. 327) their research is frequently exploratory in nature. Exploratory research is designed to take an "open, flexible and inductive approach" (Durrheim, 2006, p. 41) in attempting to maximise the discovery of new insight. The research is not predicated by a collection of a priori theoretical predictions (Stebbins, 2007), rather, it is out of the data that further questions and hypotheses emerge (Cohen et al., 2011).

The first two research questions are exploratory in nature. They aim 'to explore' students' conceptualisations. The third question, turns from the exploratory to propose emergent hypotheses from the data. While the design of the measurement tasks themselves was carefully based on theory, the structure of the interviews was such that the students lead the process – the enquiry was not steered too tightly (Cohen et al., 2011). In addition, no *a priori* predictions were made for the analysis. Patterns and categories were permitted to emerge from the data as it was explored (Wellington, 2015).

4.3.4 Case study research

Cresswell (2007) lists five approaches to qualitative inquiry: narrative research, phenomenology, grounded theory, ethnography and case studies. This research takes the form of a case study. He defines a case study as being research that "involves the study of an issue explored through one or more cases within a bounded system" (p. 73). The issue being explored was *the nature of students' constructed measurement conceptualisations*, and this was studied through a number of cases within a bounded system.

Blatter (2007) writes that case studies focus on “one or a few instances, phenomena, or units of analysis, but they are not restricted to one observation” (p. 68). The phenomenon under investigation was ‘*students’ engagement in measurement tasks*’, and it was not restricted to one observation. There were five measurement tasks that students engaged in, and this was viewed in five sets of observations.

Stake (2005) differentiates between intrinsic, instrumental and collective case studies. Collective case studies involve the selection of multiple cases that are selected because it is “believed that understanding them will lead to better understanding, and perhaps better theorising, about a still larger collection of cases” (p. 46). With this definition in mind, *the individuals as they interact* with the measurement tasks can be defined as the cases.

Case studies are also defined by the fact that they are ‘bounded’ (Cresswell, 2011). According to Stake (2005), these boundaries define what is inside and what is outside the system. This case study was not situated in a naturalistic setting. Students were placed in a problem solving situation that was created by the researcher. Tasks were given, as well as the resources with which to complete them, and a specified time was set aside to engage in them. This created very clearly defined boundaries of time and place.

In summary therefore, the research took the form of a collective case study. The issue being explored was the ‘*nature of students’ constructed measurement conceptualisations*’. The specific phenomenon being investigated was ‘*students’ engagement in measurement tasks*’, which was conducted in a series of five sets of observations. The cases were defined as ‘*the individuals as they interacted with the tasks*’ and the case study was bounded by the time and space of the interview situation.

4.3.5 Position of the researcher

This research required the students to complete five measurement tasks. The first four tasks were completed in task-based interviews with the researcher acting as the interviewer. The final task was a written test. The researcher was not present for this task and thus did not influence the participants or the setting. The documents were accessed and analysed off-site. In this section the different roles of the researcher will be described. These include participant-observer, mediator and nonparticipant observer.

4.3.5.1 Participant-observer

Blatter (2007) explains that for case studies in which the ontological view is realist, the purpose of the case is to “reveal the authentic nature of a phenomenon by getting as close as possible” (p. 69). Similarly, Stake (2010) points out that in qualitative research, the standard design requires the person who will be interpreting the data to be making the observations in the field. Both Blatter (2007) and Stake (2010), in their explanations, imply that the researcher should in some way participate directly in the research.

In this research, the researcher takes the position of a participant-observer in order to get as close as possible to the students as they engage in the measurement tasks, thus making a more in-depth interpretation of the resulting data possible. The researcher takes the role of the task-based interviewer, thus participating in the research. Observations were made and noted during the interview, and video data from the interviews were used to make further observations.

Wellington (2015), however, cautions that the very presence of the researcher will have an influence on the research situation, before even taking into account the nature of their participation. This holds implications for the validity and reliability of the research, a full consideration of which is made in Section 4.6.

4.3.5.3 Unobtrusive nonparticipant observation

The participant-observer position was not the only one taken in this research. The final task was a written test, during which the researcher was not present. The researcher therefore adopted the role of a nonparticipant observer. Savenye and Robinson (2004) write that it is often the case that the observer is present, and therefore still influences the situation to an extent, in this case, however, the researcher was not present, nor did they influence the design of the assessment. The researcher’s observations were made by examining the students’ test papers after they had been written. This document analysis would be classified as an unobtrusive form of non-participant observation (Savenye, Robinson, Niemczyk & Atkinson, 2008).

4.3.6 Summary of research approach

This research takes an interpretivist position within the paradigm of constructivism. It takes a very specific position within constructivism, which is in itself a vast paradigm. This position

has been described in terms of the view this research takes on individual psychology, individual cognition and knowledge.

The ontology, epistemology and methodology have also been established, and details regarding the approach, nature, methods and position of the researcher have been outlined.

Appendix K provides a summary of the research approach.

4.4 RESEARCH DESIGN

The research design involved conducting task-based interviews to dynamically assess the students' existing measurement conceptualisations. First year students were selected from a TVET college Engineering programme to engage in five measurement tasks, one of which was a written assessment. Thirty-nine students participated in the research project, ten of whom completed all five tasks.

The details of the research design are described in the following sections.

4.4.1 Site selection and participants

An Eastern Cape TVET college was selected for this research. This college serves both a highly industrialised urban area, as well as the western half of the Eastern Cape, a rural region characterised by high rates of unemployment and poverty (DHET, 2016c). It was formed in 2002 by the merger of four Eastern Cape technical colleges, and has eight campuses across the province (DHET, 2016c). The campus chosen for this research was situated in the industrial area of a small Eastern Cape town.

From the 2014 intake of NC(V) Level 2 Engineering and Related Design students, 39 were selected to participate in this study. These students were studying one of three NC(V) programmes: Automotive Repair and Maintenance, Fitting and Turning or Welding. It was compulsory for all students in these programmes to take Mathematics as a subject. There were 7 mathematics classes with 25 students per class.

In the following two sections, the process of site and participant selection will be described, and the student demographics of the sample group will be outlined.

4.4.1.1 Sampling methods

Purposive sampling, a type of non-probability sampling (Cohen et al., 2011), was used in this study. Intentional decisions were made regarding what site, and which student participants, would provide the richest information regarding the phenomenon being explored (Cresswell, 2011). Cohen et al. (2011) provide the argument that while purposive sampling allows greater depth of data, it restricts the breadth of the study, therefore limiting the generalisability of the findings. As the purpose of the research is to conduct an in-depth exploration of a phenomenon, this is a strength of this sampling method rather than a limitation.

There are several types of purposive sampling. Critical sampling is one example. Wellington (2015, p. 120) defines this as “choosing special cases for certain purposes”, citing as an example, selecting a college reputed to show ‘good practice’. This is the strategy that was employed in selecting the site for the research.

There are eight, multi-campus, TVET colleges in the Eastern Cape. During the time when the process of site selection and negotiation of access was started for this research, the majority of these colleges were enduring protracted, and at times violent, student unrest, as well as undergoing forensic investigations while under administration (see Fengu, 2013; Gillham, 2013; Gowa, 2013; Nkonkobe, 2013; Parliament of South Africa, 2013). The college that was chosen for the research, experienced student unrest at one of its campuses, but not the campus offering NC(V) engineering programmes (see Dayimani, 2013). The critical sampling-led choice was to approach the most stable of the eight colleges to request access and this was granted.

Maximum variation sampling was used to select the student participants. This type of sampling involves “searching for cases or individuals who cover the spectrum of positions and perspectives in relation to the phenomenon one is studying” (Palys, 2008, p. 698).

The prior schooling of TVET students, in terms of the highest grade passed, and the results they obtained, varies widely (see Sections 2.3 and 2.6). Students’ prior engagement in constructing measurement concepts, as would have happened during schooling, is taken to have had an impact on the students’ current constructions of measurement, therefore the sample needed to reflect a variety of such student backgrounds. The students’ lecturers assisted the researcher in identifying students who varied in their prior schooling experience and the sample

was selected accordingly. This is what Wellington (2015) terms a guided sampling strategy, in which “a knowledgeable guide...directs the researcher to people or settings” (p. 120).

4.4.1.2 Sample group demographics

There were 39 students who participated in this research. A list of these students, together with the relevant demographic information, is provided as Appendix L. Of these students, 18 were female and 21 male. They ranged in age from 18 to 34, the distribution of which is shown in Figure 4.5. The median age was 22.

Figure 4.5 Age of student participants

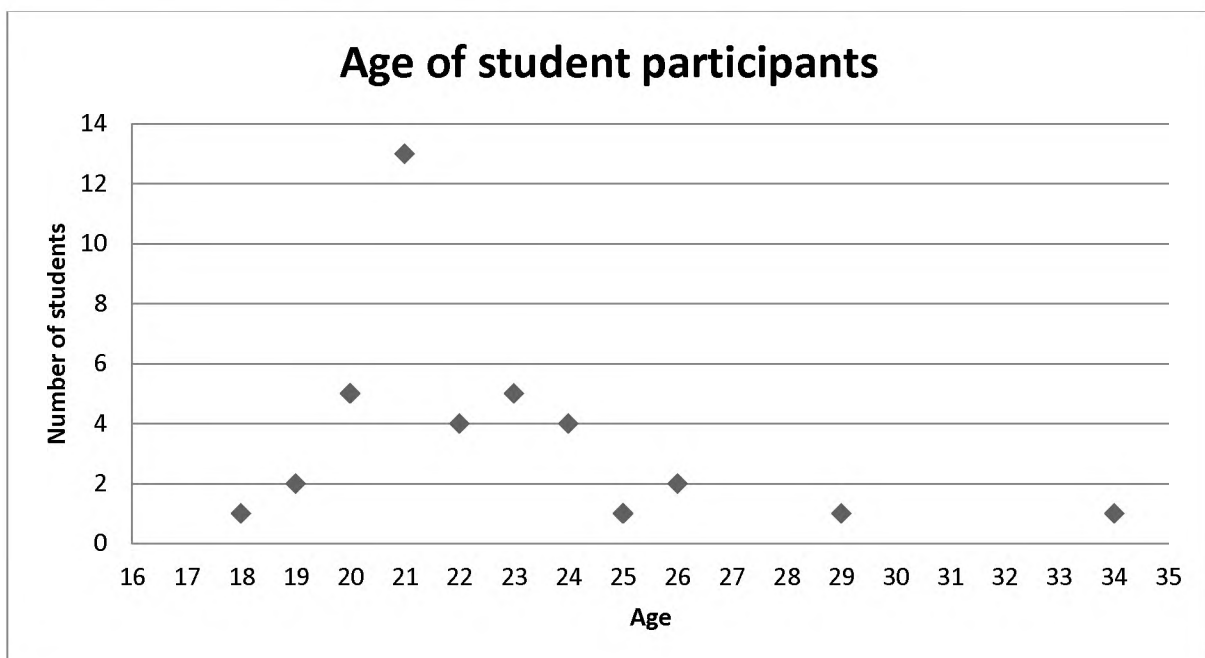

Students differed with regard to their prior schooling level of mathematics (see section 2.3.1 for the descriptions of the South African qualification levels). The highest level of mathematics passed ranged from NQF Level 1 (Grade 9 and ABET Level 4) to NQF Level 4 (Grade 12 Mathematics or Mathematical Literacy). The number of students per qualification level is shown in Figure 4.6.

Figure 4.6 Number of students per qualification level

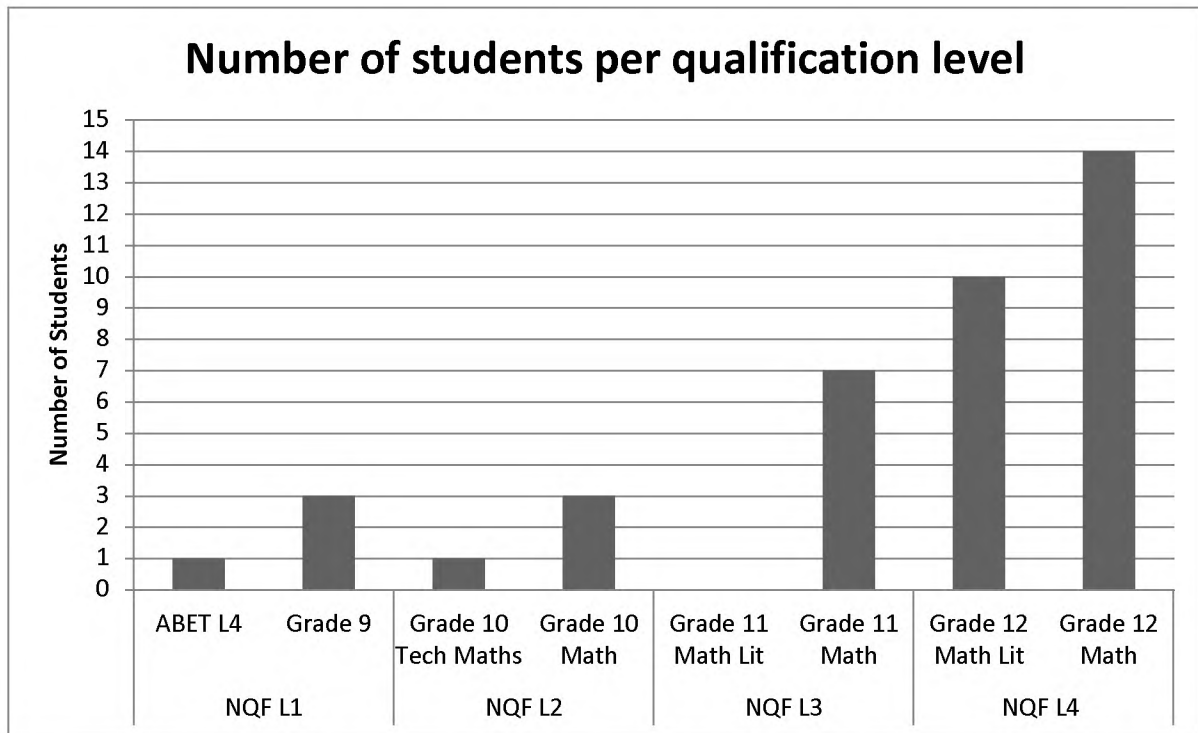

The qualification level of the programme in which they were enrolled was Level 2, however, as can be seen in Figure 4.6, many of the students had some experience of mathematics at Levels 3 and 4.

As reported in Section 2.6.1, the quintile status of the schools attended prior to entering the college is accepted to reflect the quality of education they received (van Wyk, 2015). It does not indicate the real learning that took place within each individual, as there are more complex individual and social factors that also contribute to an individual's development of concepts. Statistics do show, however that overall performance varies greatly between quintiles (Spaull, 2013). For this reason, students were requested to indicate what school they had attended previously.

Figure 4.7 Quintile status of schools previously attended by participants

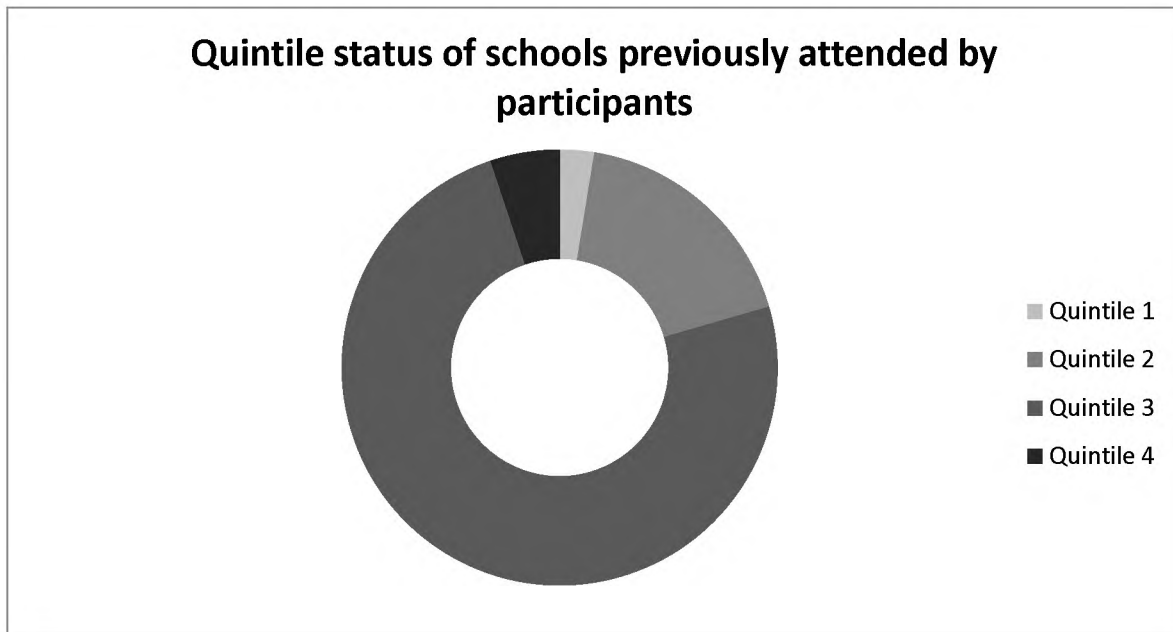

The students were studying one of three NC(V) programmes: Automotive Repair and Maintenance; Fitting and Turning and Welding. 18 students in the sample were enrolled for Automotive Repair and Design, 11 for Fitting and Turning and 10 for Welding. The breakdown of the sample in terms of NC(V) programmes is represented in Figure 4.8.

Figure 4.8 Students per NC(V) programme

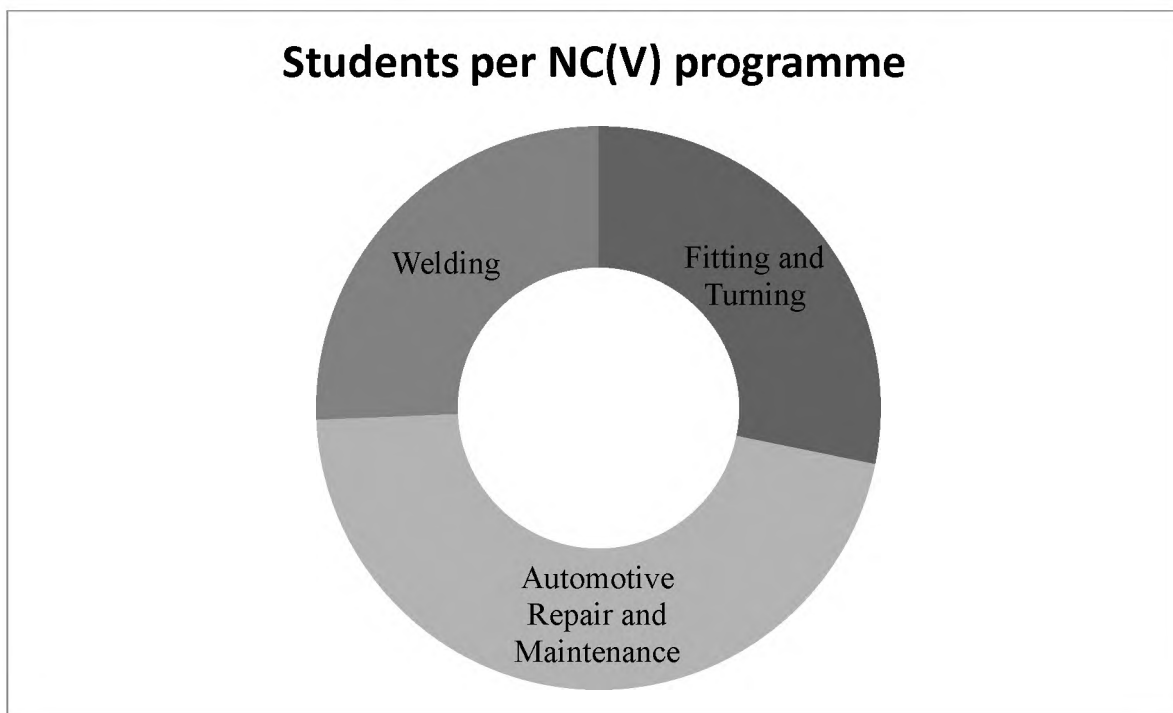

4.4.1.3 Contextual influences on sample selection

Two weeks into the data collection phase student protests had started at this college. The student protests led to the eventual closing of all campuses of the college for a period of a month (reference excluded to maintain confidentiality). Later in the same year, college lecturers engaged in protest action, again causing the college to close for a period of time (reference excluded to maintain confidentiality).

This influenced the composition of the student sample. As will be detailed in section 4.4.2, there were five measurement tasks completed by the students. The initial sample consisted of 27 students. Following the student strikes, student attendance at classes dropped considerably. Appendix M provides a list of the students participating in the study indicating which tasks they completed. As is evident in this appendix, the number of students from the sample who were still available for interview 3 had decreased.

The initial plan for interview 4 was to allow students from within the sample to form pairs to complete task 4. The number of students available from the sample by the time interview 4 was conducted had decreased to the extent that the researcher allowed students to select a peer from outside the sample for the task. This expanded the number of student participants to 39.

The final task took the form of their formal mathematics test. The results for this test contributed towards the students' final mathematics result, therefore even students who had not been attending class arrived to write this assessment. This accounts for the increase in the number of students completing task 5. Only 8 students from the initial 27 completed the full set of 5 tasks.

4.4.2 Methods

Two methods were used to gather data in this research: task-based interviews and a formal written test. Four task-based interviews were conducted, each involving a measurement task. The formal test represented the fifth measurement task.

The data was collected in the form of video recordings of the task-based interviews, and the test scripts from the formal written test were collected as a documentary source of data.

In the following sections the design of the task-based interviews and the formal test will briefly be discussed, as well as the method of using video recordings as a means of gathering data.

4.4.2.1 Task-based interviews

Structured task-based interviews were the primary means of data collection in this research. Goldin (2000) defines such interviews as involving “a subject (the problem solver) and an interviewer (the clinician), interacting in relation to one or more tasks (questions, problems or activities) introduced to the subject...in a pre-planned way” (p. 519). He also notes that such interviews can be adapted to reveal the subject’s mathematical knowledge, as well as to improve the teaching of mathematics (Goldin, 2000). Given that the aims of this research include investigating students’ conceptualisation of measurement, as well as to derive from the results suggestions regarding how to improve the teaching and learning of these concepts, this method is particularly appropriate.

Early behaviourist criticisms of task-based interviews as a research method claimed that it is only the subjects’ physical responses that were observable and measurable and that any derived conclusions regarding cognition and internal representations were scientifically indefensible (Goldin, 2000). Constructivism, however, “allows and encourages the construction of models for cognition or mental processes” (p. 536). Goldin (1997, p. 40) explains that task-based interviews generally serve two processes in research:

- (a) observing...mathematical behaviour...usually in an exploratory problem-solving context
- (b) drawing inferences from the observations to allow something to be said about the problem-solver’s possible meanings, knowledge structures, cognitive processes, affect or changes in these in the course of the interview

Hurst’s (2008) study of primary school students’ mathematical thinking included in its aims a consideration of how effective task-based interviews were in identifying modes and levels of mathematical thinking in the participants. He examined three components of numerate behaviour: mathematical knowledge, contextual knowledge and strategic knowledge, and concluded that “task-based interviews can be useful tools for helping teachers assess the mathematical thinking of their students” (Hurst, 2008, p. 295). As Maher and Sigley (2014) note, there is “substantial and growing evidence that clinical task-based interviews and their variations provide important insight into subjects’ existing and developing knowledge, problem-solving behaviours and ways of reasoning” (p. 581). When compared to traditional written tests, task-based interviews allow a deeper insight into students’ process and reasoning about mathematical ideas (Maher & Sigley, 2014).

4.4.2.2 Dynamic assessment design of task-based interviews

The approach taken in designing these task-based interviews was one of dynamic assessment (see Section 3.6). The tasks were structured in such a way as to access both the students' stable measurement conceptualisations as well as to ascertain what conceptualisations were in the process of emerging. Mediation was therefore a key part of the design.

The researcher took the role of mediator during the task-based interviews. The tasks were not given to the students to complete without available assistance, rather, the researcher provided mediation when students were unable to continue moving forward in their measurement activity after attempting to do so for some time.

Students were provided with certain *tools* to measure the object in question, and the students possessed psychological *signs*, in the form of their existing constructed measurement conceptualisations and knowledge, that mediated their actions as they engaged in the task (see Section 3.5.5 for a discussion of tools and signs).

The mediator was conceptualised to be the provider of implicit or explicit mediation (see Section 3.5.7 for a discussion on the difference between implicit and explicit mediation), in the form of *signs*, when observation of the students' measuring activity was interpreted to indicate that they required assistance in moving forward. Figure 4.5 shows the position of the mediator in relation to the measuring activity of the subject. Appendix J, which provided the model for understanding the mediated measurement interaction developed in Chapter 3, provides a more detailed illustration depicting the position of the mediator during the task-based interviews.

As Goldin (2000) cautions, "it should be completely clear... that it is the presented task, not the interpreted task, that is subject to...control" (p. 526). As Figure 4.9 shows, the mediator observes the activity of the student as they engage in the measuring activity and makes a decision about whether to provide mediation, and what mediation is to be provided, based on their interpretation of the student's activity. Furthermore, the student engages in the measuring activity according to how they have interpreted it.

Figure 4.9 The position of the mediator

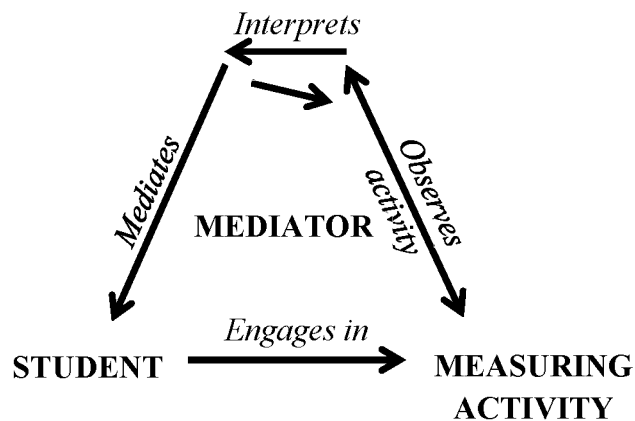

In order to answer the research questions, the amount and level of mediation required by students in order to complete the task was recorded, as well as observations of the capacity they were able to demonstrate without mediation. Mediation from the interviewer was only provided if students were unable to move forward after attempting to do so for some time, or if students deviated significantly from a course of action that would bring them closer to an accurate solution. The students' responsiveness to this mediation allowed insight into their constructed measurement conceptualisations.

The design of the tasks used in the interviews was similar to those used by Simon, Saldanha, McClintock, Akar, Watanabe and Zembat (2010) which involved the use of carefully designed mathematical tasks intended to promote activity that is expected to result in the development of a new concept. Simon et al. (2010, p. 72) "create[d] a simplified situation to study an aspect of learning at a fine-grain level". This research explored existing measurement conceptualisation, rather than learning, but the same approach was used. What Simon et al. (2010) argue is that the complexity of mathematical conceptual understanding is difficult to study, therefore the "simplified situation can... provide insight that might not have been gleaned without that effort" (p. 72).

Students were encouraged to choose their own strategies and were told that there was no fixed strategy that needed to be recalled or adhered to. This allowed the researcher to observe their freely chosen strategy, and prevented the provision of "premature guidance" (Goldin, 2000, p. 542) which would compromise the depth of the information gained from observing the student. As Goldin (2000) advises, the researcher should accept "for the time being all productions generated during the interview, without imposing preconceived notions about appropriate ways to solve the problem" (p. 542). He notes that flexibility by the interviewer is essential in task-

based interviews (Goldin, 1997). This means “being able to pursue a variety of avenues of inquiry with the learner or problem solver, depending on what takes place during the interview” (Goldin, 1997, p. 53).

Mediation was categorised broadly as being either implicit or explicit (see Section 3.5.7). A student able to complete a task after only implicit mediation was understood to have more “control over what is to be learned and is therefore further along the way towards autonomous performance” (Lantolf & Poehner, 2011, p. 20) than a student who required more explicit mediation. Examples of implicit mediation included prompts as simple as pointing, while mediation of a more explicit nature included cases where the interviewer provided brief instruction on how to carry out a particular method.

A further distinction was made regarding the type of mediation occurring in the interviews. At times mediation was focused on conceptual issues, such as asking a leading question requiring the student to recall that area is about coverage. At other times mediation was about helping students to recall a particular method for calculating area. Method-level mediation does not intervene at the concept-level, therefore, if a student is able to complete the task without conceptual mediation, they can be considered to hold a more stable and accurate conceptualisation of the domain of measurement. For this reason, concept-level mediation was taken to be of a higher-order than method-level mediation.

The following were the basic levels of mediation used: A – none; B – reassurance; C – prompt (method/concept); D – leading question (method/concept); E – instruction (method/concept); F correction (method/concept). A to D represent what was considered implicit mediation, and E and F represent explicit mediation.

The figure below provides a visual representation of these levels on a continuum from their least to most explicit forms.

Figure 4.10 Basic levels of mediation

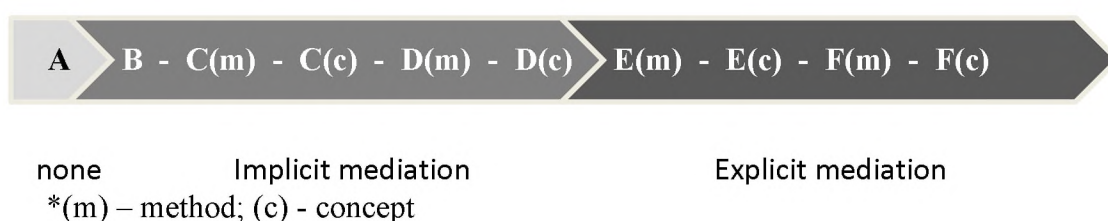

These levels can be considered to be a part of the design of the interview. They formed the basic framework of the types of mediation anticipated to be required by the students, based on the work of Lantolf and Poehner (2011), as described in Section 3.7. Basic examples of each type are provided in Appendix N.

Goldin (2000, p. 544) writes that task-based interviews should be designed to be “alert to new or unforeseen possibilities”. Despite the researcher anticipating certain levels and types of mediation as part of the “criteria for major contingencies” (p. 541) in the design, it was recognised that there may be adjustments required.

In some interviews, where the most explicit levels of mediation were not enabling students to make progress in the measuring activity, this meant that the task was abandoned in favour of using it as a teaching moment. At other times, it meant providing a type of mediation that was not anticipated to be needed prior to the interview.

The detailed design of each interview is provided in Chapter 5.

4.4.2.3 Video recordings

The depth of the observations that were made during the interviews was affected by the fact that the researcher adopted the role of interviewer and mediator as well as making observations. The interviews were therefore video and audio recorded in order to “capture the minutiae of social interaction and behaviour that [was] not possible with observation alone” (Gibson, 2008, p. 917).

The video and audio recording was made by setting a small camera up on a tripod and allowing it to record continually from the moment the interviewer left to fetch the student participant to the moment the student left the interviewing room. The camera captured an audio recording with the video recording. This was done in order to minimise the attention drawn to the camera as the interviewer did not need to turn it on or off while the student was present. No additional individual was required to enter the interviewing situation in order to manage the video recording.

The students’ permission to record the interviews was acquired during the first interview, but at the beginning of each interview the student’s attention was briefly drawn to the camera to

remind them that the interview was being recorded. This was done for ethical reasons so that students were not being recorded without their knowledge.

Significant decisions are made when setting up the video-recording equipment. The researcher needs to decide whether to take the participant or observer perspective (Hall, 2000), as shown in Figure 4.11. The image on the left shows the scene from an observer perspective, and that on the right shows the interaction from the perspective of one of the participants.

Figure 4.11 Observer and participant perspectives in video recording



(from Hall, 2000, p. 657)

The researcher also needs to decide what lies in the frame (Gibson, 2008). This forms a type of theoretical commitment (Hall, 2000). In this case, the researcher decided to acquire an observer perspective recording of the student as they engaged in the task. The frame focused only on the students and showed only the area in which the students were working. Below is a screenshot from a video of students as they completed task 4.

Figure 4.12 Observer perspective and framing of video of interview 4



This perspective and framing allowed a close view of the students' engagement with the measurement task, which is the focus of the research questions. It allowed the close analysis of every move the students made as they completed the task.

4.4.2.4 Formal written test

This task represented a “traditional means [of] evaluat[ing]...knowledge or skills” (van Gog, Remy, Rikers & Ayres, 2008, p. 784). Maher and Sigley (2014, p. 580) emphasise, in their description of task-based interviews as a data collection method, that written assessments of mathematical knowledge “do not address conceptual knowledge and the process by which a student does mathematics and reasons about mathematical ideas and situations”. They are, however, the means by which students are summatively assessed in the TVET college context (DHET, 2011), and therefore warrant inclusion in the data collected for the study.

Tall's (2013b) three worlds of mathematics includes the symbolic formal world, in which students work at a formal level with the abstract formulae and symbols associated with measurement. A written test can provide evidence of students' work in this world, particularly where students have shown in detail the processes by which they have arrived at their solutions.

The formal written test was administered after the students had attended classes in which the measurement content of the Mathematics Level 2 curriculum (DHET, 2011) was taught. These lectures were conducted by the mathematics lecturers, without the influence of the researcher, in 8 one-hour lectures. The documents were accessed by the researcher for analysis. This particular test assessed the students' ability to calculate area, total surface area and volume.

A detailed description of the test is provided in Chapter 5.

4.4.3 A summary of the research design

This section has described the research design, from site selection and sampling to providing details of the methods. Thirty-nine students participated in the research, with ten completing all tasks included in the research. The research design included four task-based interviews in which the students engaged in mediated measurement tasks, and the final task took the form of a written test. The task-based interviews were designed to dynamically assess the students' existing measurement conceptualisations. Included in their design was careful consideration of

the role of the interviewer as mediator and the form of mediation that would be available to the students.

4.5 DATA ANALYSIS

Although there was a strong influence of theory in the design of the measurement tasks used in the task-based interviews, the open and inductive approach taken in the analysis of the data is minimally theory-led. It is strongly linked to the data gathered and the observations made during the interview.

4.5.1 Overall approach

The overall approach to the data analysis in this research can be described as “open, flexible and inductive” (Durrheim, 2008, p. 41). Understanding and knowledge of students’ constructed measurement conceptualisations has been pursued by establishing a relationship between observations made during their engagement with measurement tasks (Fox, 2007) and theory. The researcher builds “patterns, categories and themes from the bottom up by organising the data into increasingly more abstract units of information” (Cresswell, 2014, p.186).

Through the process of inductive reasoning, the researcher is able to “develop generalised propositions, hypotheses and theory from empirical observations” (Fox, 2007, p. 430). Wellington (2015, p. 40) emphasises that “the theory is firmly grounded in [the data] and [is] derived from it”. This process allows the researcher to propose theory based on the data gathered regarding students’ measurement conceptualisations, including propositions regarding how to best facilitate the students’ construction of accurate and stable measurement conceptualisations. One can therefore categorise the purpose of the overall data analysis approach taken in this research to be ‘generative’ (Clement, 2000).

Both constructivist and sociocultural researchers have developed theoretical tools that could have been used for analysis in this study, however, the exploratory nature of the research demanded a more grounded approach. Inductive analysis was guided by the data as it emerged, and theory was later referred to in order to better understand the “propositions, hypotheses and theory” (Fox, 2007, p. 430) that arose.

The potential conflict in utilising ideas from both Piagetian and Vygotskian perspectives, as discussed in section 3.7, also contributed to the decision to apply a grounded approach to the

analysis. This allowed the use of tools derived from their work to be blended in order to view the product of learning, without imposing the analytical perspective of either one.

4.5.2 Analysing the task-based interviews

Data collection can be viewed as both prior and parallel to data analysis (Lesh, 2000). In offering mediation during the interview, the interviewer interpreted the actions and utterances of the students and, based on this interpretation, made a decision as to the type of mediation that was most appropriate. This was itself a form of analysis, and is represented in Figure 4.13.

Figure 4.13 Parallel data collection and analysis

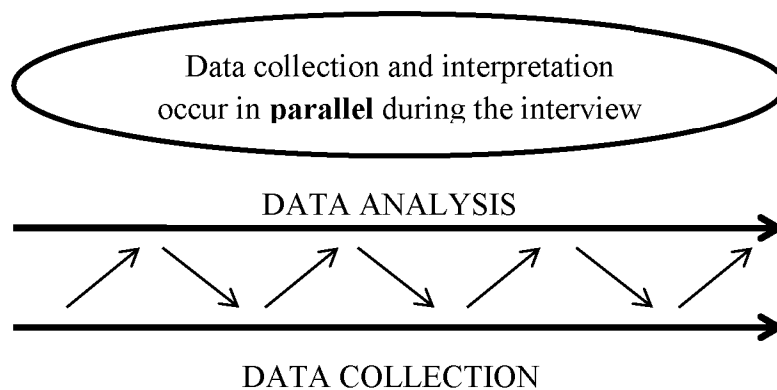

From Lesh, 2000, p. 665

A process of inductive, generative data analysis then followed the data collection. The video recordings allowed repeated viewings of the interviews, thus continual, constant comparison was possible in repeated iterative cycles. The figure below best represents the timing of the analysis in this research:

Figure 4.14 Timing of data analysis

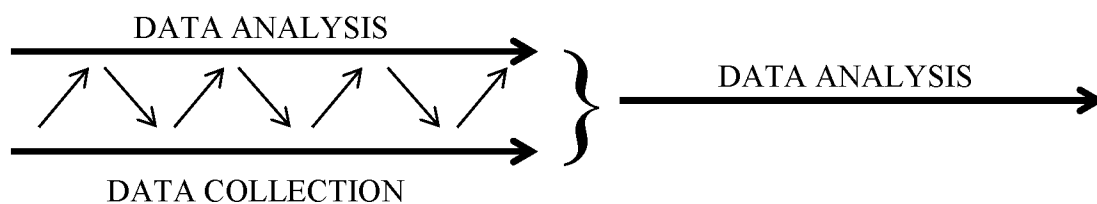

Adaptation of Lesh, 2000, p. 665

4.5.2.1 First steps in processing raw data

The raw data from the task-based interviews (observation notes, artefacts and video recordings) and the raw data from the written tests (test scripts) were collected and filed. The observation

notes, artefacts and test scripts were scanned and filed electronically as well as in their original, hard copy form.

The process of summarising the data was then initiated. Observation notes and the video-recordings were summarised together in order to arrive at a comprehensive description of the interviews. A descriptive narrative of the interview was created that included observation notes made during the interview, a description of the mediation provided by the interviewer and the actions and utterances of the student. As the primary role of the researcher was that of ‘interviewer’ during the task-based interviews, it was not possible to make extensive observation notes while the student worked, but there were a number made.

Figure 4.15 serves as a basic illustration of the composition of this narrative. The arrow denotes the passage of time from the beginning to the end of the interview. The aim at this point was “not to codify abstract regularities but to make thick description possible” (Geertz, 1973, p. 26). The figure shows the components of the narrative with the codes ‘S’, ‘M’ and ‘O’, but it should be noted that the data itself was accordingly still in its “thick” (p. 26) descriptive form and these moments were not yet coded.

Figure 4.15 The composition of the interview narrative

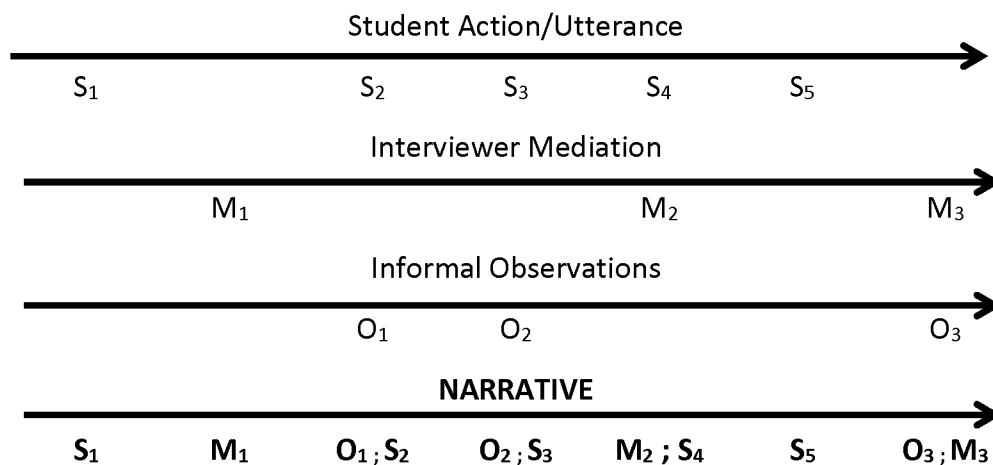

4.5.2.2 The inductive process

The next step in processing the data, and the first major step in its analysis, was to code the interviewer mediation. As there were a number of predetermined types of mediation built into the design of the task-based interviews, this provided a starting point for the process. As described in Section 4.4.2.2, these were coded according to the categories shown in Figure 4.10.

A further layer was therefore added to the narrative: the code assigned to the level of interviewer mediation in the manner shown in Figure 4.16.

Figure 4.16 First level of coding of the narrative

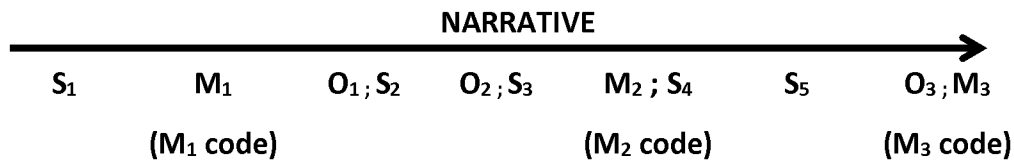

Only one interview narrative was created at a time, with its initial mediation coding. After the creation of each narrative, the codes and details of the new narrative were closely compared to the existing ones in search of possible patterns and themes. This signalled the true beginning of the inductive process of “working back and forth between the themes and the data base” (Cresswell, 2014, p. 186).

Iterative cycles of data analysis were performed in what can be defined as “constant comparison” (Savenye et al., 2008, p. 772). This iterative process was continued until there were no new categories of student action, or mediation, emerging (Savenye et al., 2008). In order to verify each emergent pattern of category, the thickly described narrative as well as the raw video data was consulted.

In some instances, a code appeared so frequently that it became clear that there were subtleties to each example of its use that allowed the category to split. In others, several coded moments could be collapsed into one category.

Wellington (2015) provides the following diagram summarising the constant comparative method of refining categories, which reflects the process taken in this research:

Figure 4.17 Process of constant comparison

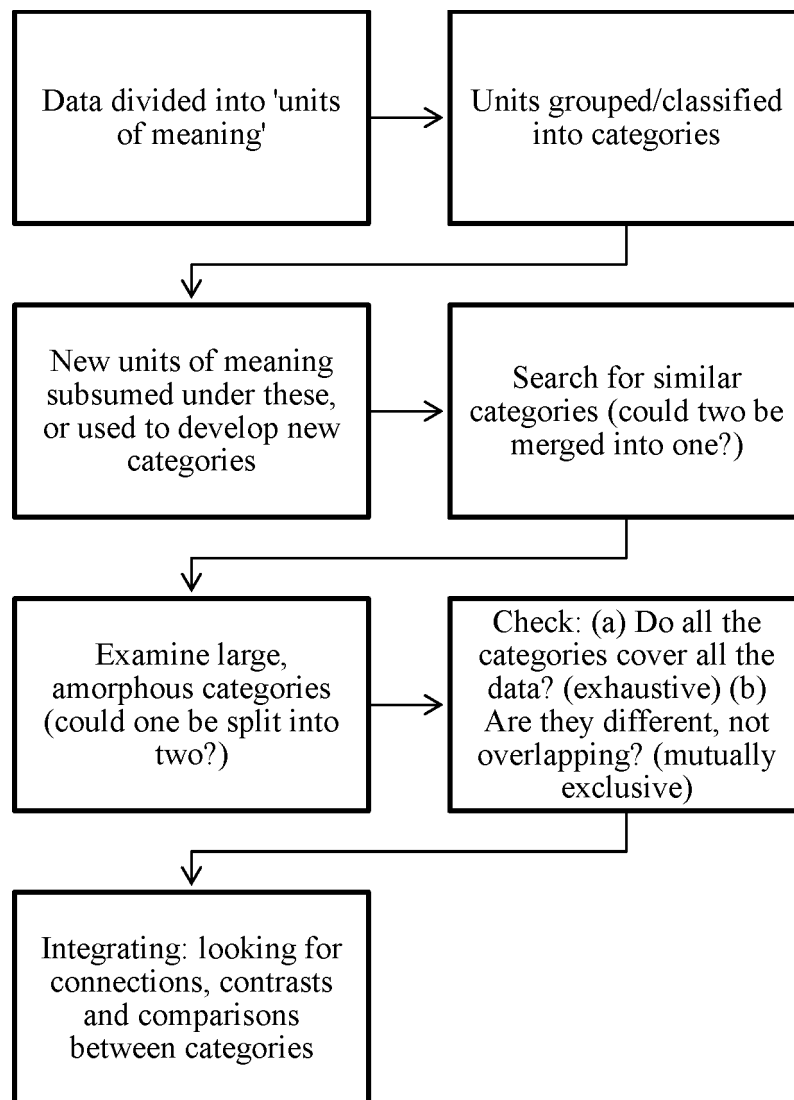

From Wellington, 2015, p. 263

Saturation in the analysis (Saumure & Given, 2008) was considered to have been reached when no further patterns could be discerned and no further categories were emerging from the data. Wellington's (2015) diagram (Figure 4.16) reveals the questions asked to determine whether this point had been reached:

1. Can any categories be combined to form one?
2. Can any one category be split into two (or more) categories?
3. Do the categories account for all the data?
4. Are the categories mutually exclusive?

An answer of 'no' to questions 1 and 2, and 'yes' to questions 3 and 4, was taken to indicate that saturation had been reached.

4.5.2.3 The role of critical incident analysis

Critical incident analysis is a qualitative research method that is effective as an exploratory and investigative tool (Butterfield, Borgen, Amundsen & Maglio, 2005). It was utilised in this research in the selection of events for analysis from the task-based interviews.

This method was developed by John Flanagan in 1954 as a procedure for "collecting observed incidents having special significance and meeting systematically defined criteria" (Flanagan, 1954, p. 327). Flanagan (1954, p. 327) defines what is meant by an incident:

By an incident is meant any observable human activity that is sufficiently complete in itself to permit inferences and predictions to be made about the person performing the act. To be critical, an incident must occur in a situation where the purpose or intent of the act seems fairly clear to the observer and where its consequences are sufficiently clear to the observer and where its consequences are sufficiently definite to leave little doubt concerning its effects.

The method was developed for use in the field of aviation (Flanagan, 1954), but has since been applied more widely, including in the field of education research (Butterfield et al., 2005). It is a flexible approach that Flanagan (1954) noted should be adapted to the particular research problem and context.

Harrison and Lee (2011), for example, explored the value of critical incident analyses in initial teacher education by allowing student teachers to identify what they considered to be critical incidents in their classroom experiences. These critical incidents were used to initiate professional learning dialogue with the aim of improving "critical reflective practice" (Harrison & Lee, 2011). Similarly, Lister and Crisp (2007) provided student and practice teachers with a structured critical incident analysis framework developed to guide student teachers in reflective practice. These teachers found that the use of this technique assisted them in understanding "how theoretical concepts influenced their thoughts and actions" (Lister & Crisp, 2007, p. 52) during their teaching placement.

In this research, critical incident analysis was utilised during data summary and analysis of the task-based interviews. Critical incidents were identified in the video data and transcribed and described in rich and precise detail. The criteria for an incident to be classified as 'critical'

included the following: (1) it was clear what led up to the incident; (2) it was possible to provide a detailed description incident; and (3) the outcome of the incident was clear (Butterfield et al., 2005).

Critical incidents included for analysis in this research were those moments in which students performed actions in their measurement of the objects in the task, verbalised what they were thinking as they performed the task, made gestures during their verbal explanations or recorded in writing their calculations as they worked. In addition, they included the moments in which mediation was offered, and the students' subsequent actions. These formed the broad, basic data considered during data analysis. As Cohen et al. (2011) point out, a behaviour may occur only once in the research data, but should not be ruled out on the basis that it occurred only once. Every such critical incident was therefore included for analysis.

At a more detailed level, there were critical incidents identified from the video and written data as points of data that were 'richer' than others, or that stood out in their uniqueness. This included examples where students provided more detailed and in-depth explanations of their working or where they wrote more detailed and in-depth notes during the task. In addition, it included those moments in which students approached a task with an original method different to those used by the majority. Cohen et al. (2011) explain that:

...sometimes one event can occur which reveals an extremely important insight into a person or situation...[these] appear to the observer to have more interest than other ones and therefore warrant greater detail and recording than other events; they have an important insight to offer (p. 424).

These more detailed critical incidents were crucial to the constant comparison process, as in their richness they suggested certain initial categories and permitted insight into the slightly less descriptive critical incidents. As analysis progressed, these deeper critical incidents, where they arose, served to confirm or disconfirm the validity of the initial categorisation, and therefore further informed the process. This is, according to Butterfield et al. (2005), a hallmark of the critical incident technique as applied to data analysis.

4.5.2.4 Basic and emergent mediation codes

The basic mediation levels and types were provided in Section 4.4.2.2. Those had been built into the design of the interviews. As the data was analysed through iterative cycles of constant comparison, there were a number of additional categories that emerged when patterns revealed

that “large, amorphous categories” (Wellington, 2015, p. 263) could be split into two. The full list of mediation levels and types are provided in the figure below:

Figure 4.18 List of basic and emergent mediation levels and types



*(m) – method; (c) – concept; (a) – artefact

These codes refer to the following:

- A: no mediation
- B: reassurance
- C(m): prompt (method)
- C(c): prompt (conceptual)
- P(a): provision of an additional artefact
- D(m): leading question (method)
- D(p): leading question (process)
- D(c): leading question (conceptual)
- R(a): reference made to artefact
- E(m): instruction (method)
- E(c): instruction (conceptual)
- F(m): correction (method)
- F(c): correction (conceptual)

Artefacts are defined as objects within the space of the measurement activity. The mediator did not become involved in the performance of the task, but did at times refer to (by pointing) an object already present, or add an object, e.g. a calculator, to the tools available to the student. This was still considered *sign* mediation, as no explanation was provided as to how to make use of the object in question and in what way it would be useful. This interpretation was left to the student.

The category D(m), when analysing the data, contained many examples in which the mediator had merely provided an extra artefact, thus leading the student to understand that this artefact would be useful, but without any further explanation. This is more implicit than a verbalised, method-level leading question, and was thus separated out into its own, more implicit, category as P(a).

Similarly, the category of E(m) contained many examples in which the mediator made less instructive reference to an artefact already present, rather than providing more descriptive, verbal instruction about the method to follow to solve the problem. Therefore, this category (R(a)) is less explicit than E(m).

Appendix N provides a full list of the mediation levels, including examples of each. Their emergence will be described in each relevant presentation and analysis chapter (Chapters 6 to 9).

4.5.3 Analysing the written test

The researcher accessed the student scripts from the written measurement test that they wrote subsequent to two weeks of instruction on measurement in their mathematics classes.

Students had been instructed to show as many of the steps taken in their calculations as possible, and not to simply provide a final solution. As such, their responses could be summarised and analysed for recurring patterns. Iterative cycles of data analysis, involving constant comparison, were carried out in a manner similar to that used in the analysis of the task-based interviews.

4.5.4 A summary of data analysis techniques

The overall approach to the analysis of the data was “open, flexible and inductive” (Durrheim, 2008, p. 41).

Interview narratives were constructed from the raw data by noting moments of mediation, student actions and further informal observations as critical incidents. A narrative was constructed for each interview before the full group of interviews was examined as a whole. As a first step in analysis, moments of mediation were coded according to the basic levels identified during the design of the interviews. Several iterative cycles were performed when coding the mediation and new categories emerged from the data.

A similar approach was taken to analysing students’ performance on the written test. Responses were summarised and analysed and iterative cycles of analysis similarly highlighted recurring patterns.

4.6 VALIDITY AND RELIABILITY

It is recognised that one of the major criticisms in studies where the researcher is a participant in the research is the question of the validity of the findings (Savenye & Robinson, 2004). In addition, the inductive and generative approach to the analysis of the data has similarly been criticised for being “less scientific” (Clement, 2000, p. 548) and therefore lacking in validity and reliability. Particular care has been taken to address such criticisms while designing this research as well as analysing and interpreting the data.

Denzin and Lincoln (2005) argue that the traditional criteria for evaluation, validity and reliability, need to be reconceptualised when evaluating qualitative, interpretive research. Lincoln and Guba’s (1985) trustworthiness criteria of credibility, transferability, dependability and confirmability are frequently used to evaluate qualitative research. Schwandt (2007, p. 299) provides definitions for each of Lincoln and Guba’s (1985) criteria:

Credibility: “providing assurances of the fit between respondent’s views...and the inquirer’s reconstruction and representation of the same”

Transferability: “providing readers with sufficient information on the case studied such that readers [can] establish the degree of similarity between the case studied and the case to which findings might be transferred”

Dependability: “ensuring that the process was logical, traceable and documented”

Confirmability: “call[ing] for linking assertions, findings, interpretations ... to the data in discernible ways”

Onwuegbuzie and Leech (2007) have identified several methods to increase the accountability of the qualitative researcher and address Lincoln and Guba’s (1985) trustworthiness criteria. Among these are: persistent observation; triangulation; leaving an audit trail; member checking; clarifying researcher bias; peer debriefing; rich and thick description; and quantitising data (Onwuegbuzie & Leech, 2007).

4.6.1 Persistent observation

In this research, persistent observation was made possible by recording the interviews. This allowed the researcher to carefully “separate relevant from irrelevant observations” (Onwuegbuzie & Leech, 2007, p. 239) when identifying patterns and categorising data into codes during the constant comparison process. The same was the case for the written test as

the researcher was able to keep copies of the tests in order to return to the originals multiple times. This persistent observation of the original data, as well as the persistent scrutiny of the emergent patterns and categories during the constant comparison process supports the claims made in the interpretation of the data in this research.

4.6.2 Triangulation

Triangulation “reduces the possibility of chance associations” (Onwuegbuzie & Daniel, 2003) and can be defined as the use of more than one data collection method (Cohen et al., 2011). In this research two main methods were used to explore students’ engagement with measurement tasks: task-based interviews and a formal written test. The triangulation of methods, however, extends beyond this distinction. The task-based interviews themselves were structured differently and focused on different types of measurements and measurement activity.

The first two interviews were similar in their structure, with the student working on a simplified, non-contextualised measuring task. The measuring task and concepts would also have been school-met for these students. In the third interview they were presented with the task of calculating a composite measurement, and in the fourth they collaborated with a peer to solve a practical, real-world measurement problem. Together the interviews allowed a more nuanced view of the students’ measurement conceptualisations than a single design would have permitted.

4.6.3 Leaving an audit trail

Leaving an audit trail involves careful compilation and storage of all documents and records pertaining the data collection, analysis and interpretation. Cohen et al. (2011, p. 312) list “raw data, records of analysis and data reduction, reconstructions and syntheses of data [and] process notes” as some of the information required. While the research report cannot include all of these, they are available for scrutiny. The video data, for ethical reasons, are not available for viewing, but their transcriptions are.

4.6.4 Member checking

Member checking was incorporated in the task-based interviews. Where appropriate and non-intrusive the researcher asked probing questions in order to elicit students’ explanations of what they were thinking and doing as they worked. This informal member checking assisted the

researcher in interpreting the interview data both in parallel to the data collection process (see Figure 4.13) and subsequent to the interviews (see Figure 4.14).

4.6.5 Clarifying researcher bias

It was crucial to carefully assess any possible researcher bias, in particular due to the researcher playing a number of roles in the research. Onwuegbuzie and Leech (2007, p. 236) define researcher bias as “when the researcher has personal biases or *a priori* assumptions that he/she is unable to bracket” and warn that when this remains unchecked there is the possibility of contamination of data collection, analysis and interpretation.

The researcher had experience working in the TVET context as a mathematics lecturer, which was the stimulus for this research. This experience, however, did lead to several assumptions as to what will occur in the interviews. One assumption that needed to be deliberately bracketed was that students would struggle in some way with the measurement tasks. While the researcher did not hold the personal view that TVET students are somehow ‘less capable’ than students in other settings, the pervasive language used in discussions around TVET mathematics performance is negative and it is easy to slip into viewing and describing the students’ performance in such terms.

In order to prevent this from contaminating the data collection, particular care was taken to delay mediation for as long as possible during the interviews. This was to allow the students sufficient time and space to display their knowledge, rather than mediating too quickly on a premature assumption that the student was struggling. The data could then speak to the capabilities of the students rather than to exclusively highlight the moments in which they required mediation.

Bias was also a risk in the data analysis and interpretation phases. The researcher needed to allow patterns and categories to emerge independent of her own views about the students’ performance in the interviews or the test. By remaining cognisant of this risk, and by constantly returning to the raw data to confirm whether codes had been correctly assigned, this bias was minimised.

In constructivist research the results will always be a report of an interpretation of events, but acknowledgement of potential biases and consistent reflection on the part of the researcher can limit the risk of the researcher contaminating the research with their own assumptions.

4.6.6 Peer debriefing

Peer debriefing involves acquiring “external evaluation of the research process” (Onwuegbuzie & Leech, 2007, p. 244). In order to acquire such evaluations an effort was made to present emergent findings at a number of conferences and speaking opportunities both prior to data collection (see Vale, 2014), during data collection and parallel analysis (see Vale, 2015a; 2015b) and in the later stages of data analysis and interpretation (see Vale 2015c; 2015d; 2016). This peer debriefing provided feedback from those Cohen et al. (2011) might refer to as “disinterested peer[s], in a manner akin to cross-examination, in order to test honesty, working hypotheses and to identify the next steps in the research”.

4.6.7 Rich and thick description

Rich and thick data was gathered in this research. From the video recordings of the interviews, descriptions were written that focused on the dialogue between the interviewer and the student, the gestures made by the students while speaking and the actions taken by the students while working. This focus on multiple levels of action deepened the data and provided support to the claims made when interpreting the data.

As described in Section 4.5.2.3, critical incident analysis was utilised as part of the data analysis approach. Data points that were considered particularly ‘critical’ included those that contained more detail than others, i.e. more detailed verbalisations and more detailed written work. These lent themselves to richer and thicker description. The identification of these particular critical incidents, and their use to confirm or disconfirm certain categorisations, served to enhance the trustworthiness of the claims made in this research.

The critical incident analysis technique has, in itself, been shown to be reliable and valid. Butterfield et al. (2005) describe two historical studies that sought to establish the reliability and validity of the critical incident analysis approach to data analysis: that of Andersson and Nilsson (1964) who focussed on the job performance of grocery store managers, and Ronan and Latham’s (1974) who studied the performance of pulpwood producers. Both of these focussed on establishing the reliability and validity of their selection of critical incidents, and their subsequent analysis of these (see Andersson & Nilsson, 1964; Ronan & Latham, 1974). Both studies arrived at the conclusion that this method has satisfactory reliability and validity.

In contemporary qualitative research, it is the trustworthiness and credibility of the technique that is sought, rather than the more positivistic measures of validity and reliability. Butterfield et al. (2005) note that “there appears to be a lack of literature regarding a standard or recommended way to establish the trustworthiness or credibility of the results in a critical incident technique study” (p. 485). They describe a review of 19 masters and doctoral dissertations from the Counselling Psychology programme at the University of British Columbia, in which the credibility and trustworthiness checks were examined and used to establish a list of nine credibility checks that can be used to “enhance the robustness of ... findings” (p. 486). Of those nine, those used in this study included (Butterfield et al. 2005):

Conducting more than one interview: each student participated in more than one interview, and each interview was conducted with multiple students

Discussion of tentative categories with an expert: as patterns and categories emerged these were discussed with a more experienced researcher in mathematics education and the categories considered for refinement when insights were gained during these interactions

Creation of main categories was based on the number of participants demonstrating a specific type of incident: while unique incidents were noted and described, it was the incidents which were displayed by a larger number of students that informed the categorisation of data

Comparing the categories to the existing research and literature in the field to determine whether there is support for them: existing research and literature was sought and consulted as each category emerged

Video recording the interviews in order to attain an accurate reproduction of the action and words of the participants: the video recordings of the task-based interviews, as well as the students’ written tests, as an audit trail available for verification of the veracity of the transcriptions and descriptions.

4.6.8 Quantitising qualitative data

Onwuegbuzie and Daniel (2003) write that qualitative researchers do make use of terms such as ‘frequently’, ‘more’, ‘most’ or ‘less’. Despite their relative nature, these are, however, quantitative concepts (Onwuegbuzie & Daniel, 2003). If a qualitative researcher makes such claims in relation to their data, without supporting this with the counts of the observations that allowed them to make these conclusions, the reader is forced to accept the researcher’s interpretation without evidence. Cohen et al. (2011) use the term ‘data transformation’ to

describe the counting of qualitative observations, while Onwuegbuzie and Daniel (2003) refer to it as quantitising. Quantitative terminology has been used in this research to make certain claims, and where this is done, the supporting counts are provided in the form of tables and graphs.

4.6.9 Summary of approach to ensuring trustworthiness

In this research, eight of the measures suggested by Onwuegbuzie and Leech (2007) to enhance trustworthiness, were applied. These included persistent observation; triangulation; leaving an audit trail; member checking; clarifying researcher bias; peer debriefing; rich and thick description; and quantitising data.

4.7 ETHICAL CONSIDERATIONS

Savenye and Robinson (2004, p. 1063) write that “all researchers must be concerned with preventing subjects from being harmed, protecting their anonymity and privacy, not deceiving them and securing their informed consent”. The design of this research and each step in the data collection, analysis and reporting was guided by these principles.

Prior to engaging in the research, a proposal was presented for approval and ethical clearance from the Rhodes University Education Faculty Higher Degrees’ Committee. Subsequent to obtaining this approval, official permission to conduct the research was sought from “gatekeepers” (Cresswell, 2011, p. 24) at various levels at the chosen TVET college. Permission was granted by the campus manager, the head of NC(V) mathematics, the head of NC(V) Level 2 Mathematics, and the two Level 2 Mathematics lecturers with whom I directly worked.

The students approached to participate in the research were informed about the purpose of the research. This knowledge allowed the students to consider themselves partners in the research and assisted in building rapport with the researcher. Time was devoted to informal conversation and the building of rapport. It was acknowledged that the situation may have felt uncomfortable due to the researcher being a stranger, and students visibly relaxed after this.

After the purpose of the research had been explained, the students were also explicitly told what participation in the research would involve. Each interview would require a sacrifice of time, but would offer the benefit of a learning experience in measurement. After explaining the

costs and probable benefits, the students were asked whether they would be prepared to participate.

It was emphasised that participation was voluntary, and that they could withdraw at any stage in the project without affecting their relationship with the college or their lecturers. Students were guaranteed anonymity in any reports (pseudonyms have been used throughout), and were assured that all records from the interviews would remain confidential and would be stored securely.

Students were required to sign a consent document (attached as Appendix O) before the task-based interview was started, but this document was not used to coerce them into participating in any of the subsequent interviews. The students were all over the age of 18, and were therefore able to give consent without the need for additional permission from a parent or guardian.

As Gibson (2008, p. 917) emphasises, “video recording raises unique ethical issues related to maintaining privacy and confidentiality”. Students’ attention was drawn to the video camera at the beginning of the first interview and the purpose of the recording was explained. Students were assured that the recording was for the researcher to use for analysis and that no one outside of the research project, including their lecturers, would view it. The videos would also not be used in any public presentation in a manner that would compromise anonymity. One of the measures taken to ensure this has been to be highly selective of the images used in this report. No screenshots have been included in which the whole face of a student can be seen, and images of the interviews have been used sparingly.

There were unique ethical challenges in this research as a result of the student and staff protests which disrupted college activities during the time of data collection. The campus was evacuated during one of the task-based interviews. This interview was terminated and all staff members were asked to leave the site for the remainder of that week while safety concerns were addressed. Safety could not be guaranteed for a month after this evacuation, and it was decided that data collection would only resume once the campus was fully operational and secure.

Furthermore, because of lost academic time, lecturers were providing extra lessons after college hours in order to assist students to catch up. This required the researcher to adjust the timing of the task-based interviews so as not to conflict with these additional lectures. It is essential in any research to be “respectful to the research site” (Cresswell, 2011, p. 230) as well

as safeguard the welfare and interests of the students (Savenye & Robinson, 2004). In this case it required the adjustment of some of the data collection plans.

In the data analysis and the reporting of the findings of this research, the primary concern was to uphold the ethical principle that “data should be reported honestly, without changing or altering the findings to satisfy certain predictions or interest groups” (Cresswell, 2011, p. 24). Every data point from every interview has been included in the analysis. No data or findings have been altered or eliminated to serve any purpose, and all has been reported honestly.

4.8 SUMMARY

This chapter has presented the research approach, research design and data analysis techniques employed in this study. In addition, care has been taken to describe how trustworthiness was enhanced, as well as to describe the measure taken to ensure that the research was conducted in an ethical manner.

The task-based interviews were described here only in broad terms. Their detailed description is provided in Chapter 5 before the presentation and analysis of the data that emerged from them is provided in Chapters 6 to 9.

CHAPTER 5

THE FIVE MEASUREMENT TASKS

5.1 INTRODUCTION

Four measurement tasks were designed to explore the constructed measurement conceptualisations of the student participants during the task-based interviews. The fifth measurement task in which students engaged was a formal written test. The purpose of these tasks was to allow a snapshot of the existing measurement conceptualisations of students to be taken. While the task-based interviews were conducted over a period of time, there is no longitudinal follow-through from Task 1 to Task 5 built into the design. Each task in itself permitted a view of a specific set of aspects of measurement conceptualisation.

The first two were classic tasks that had appeared in several other studies assessing students' basic conceptual knowledge in the domains of area (e.g. Barrett et al, 2011; Feikes, Schwingendorf & Gregg, 2009) and volume measurement (e.g. Ben-Haim et al., 1985; Voulgaris & Evangelidou, 2004). These measurements were both chosen as examples of "tangible and directly experienced quantities" (Smith et al., 2011, p. 618).

These tasks were not contextually situated, nor did they represent tasks that students would realistically be required to complete in a workplace situation. They were, however, chosen for their faithfulness to the conceptual essence of the measurement. To complete each task, students required a strong grasp of the embodied measurement concept in question and did not need to employ any symbolic procedures in order to measure the quantity.

Due to the fact that more tangible quantities lead to composite quantities, such as rates (Smith et al, 2011), the third task required students to measure fluid volumetric flow rate. Volumetric flow rate is defined by Inamdar (2012) as "volume of fluid flowing past a section per unit time" (Inamdar, 2012, p. 7). The task was modelled on that used by Inamdar (2012) in which the volumetric flow rate was calculated for a tank with an aperture through which fluid flowed out.

Work is very seldom performed by an individual in isolation and "problem solving work carried out in the world today is performed by teams" (PISA, 2015, p. 4). For this reason, the fourth task matched a more realistic workplace situation in allowing students the opportunity to collaborate with a peer while working on a more complex, contextually situated

measurement task. The students were not viewed, for analysis, as a dyad. The focus remained on one student and their responsiveness to mediation, which in this case originated from the interviewer as well as the peer. Sign mediation was provided by the interviewer, while tool and sign mediation could be considered to be provided by the peer due to the collaborative nature of the task.

The form of assessment chosen by the TVET college to assess students' ability to measure and calculate measurements was a formal written test. This was therefore selected as the fifth task for analysis.

Chapter 4 (Section 4.4.2.1) provided information about the overall design and process followed in the task-based interviews. This chapter will provide a detailed description of each of the tasks presented to the students in these interviews, as well as the written test.

5.2 TASK ONE: MEASURING THE AREA OF AN IRREGULAR SURFACE

Twenty-seven interviews were conducted for Task 1. Students were asked to calculate the area of an irregular surface, and were given a small, square tile to use as a unit. Only one unit tile was provided so that students were required to devise an iteration strategy. While the question was of an abstracted nature in that it provided no context to the problem, it did require a strong conceptual grasp of measurement, area, as well as the use of units. Students were provided with the unit, rather than needing to make a choice between artefacts and/or units so that the analysis could be focused on the application of an embodied understanding of area. This focus would have been diminished should the extra requirement of an appropriate choice of artefact and unit be included in the task.

In order to complete the task, area needed to be understood as “an amount of region (surface) that is enclosed within a boundary and ... that this amount of region can be quantified” (Baturu & Nason, 1996, p. 238). The key understanding of the measurement process required in this task was that of the “repetition (or iteration) of units” (Outhred & McPhail, 2000, p. 491) as it required students to place the tile systematically over the area with no gaps or overlaps. Different covering strategies could be expected depending on the student's understanding of area.

Students needed to apply comparative reasoning, in which “one must relate each object to some unit object and report its size in terms of those units (Barrett, Cullen, Sarama, Clements,

Klanderma, Miller & Rumsey, 2011) as well as to understand that the number of these units represents the measure of the area (Outhred & McPhail, 2000). Therefore, the area of the surface would be calculated as the number of tiles that would be required to cover the surface.

Students were provided with a 2-dimensional irregular shape, a single tile (1cm × 1cm), a straight edge (uncalibrated ruler), a pencil and a piece of paper. They were instructed to measure, as accurately as possible, the area of the surface using the tile as a unit.

To construct a rectangular array within the surface would require approximately 48 tiles. When considering the remaining area, approximately 14 additional unit tiles would be required. The approximate solution was therefore 62 square units.

Figure 5.1 The question: Measure the area of the surface using the tile as a unit

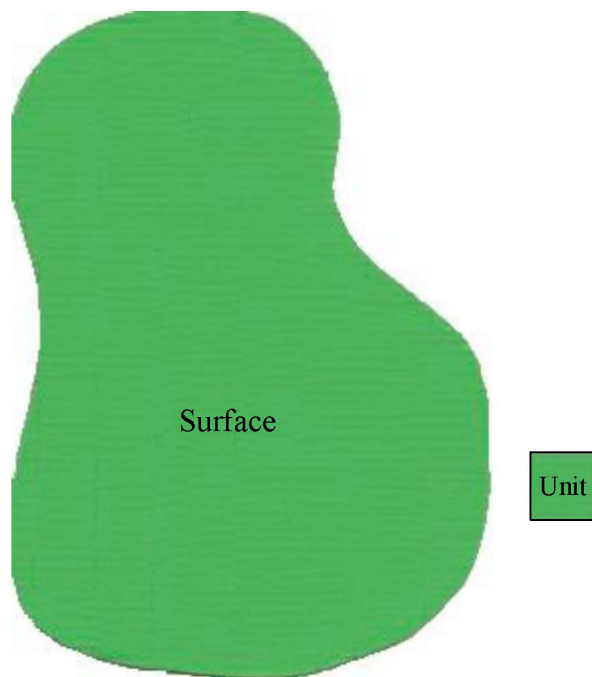

Figure 5.2 Student working on Task 1



5.3 TASK TWO: MEASURING THE VOLUME OF A CUBE

Twenty-six interviews were conducted for Task 2. Students were required to calculate the volume of a given cube, and were given a small unit cube to do so. Only one cube was provided so that students would need to devise a strategy that would allow them to iterate the unit. The task was explained, but before starting the measurement process, the interview opened with the question “what is volume?”

Volume needed to be understood to be the amount of space that an object occupies, and the size of the volume was to be reported in terms of the size of the unit cube. Students required the same key understanding of the measurement process (Outhred & McPhail, 2000) and comparative reasoning (Barrett et al, 2011) as for Task 1.

In order to calculate this volume, the three-dimensional unit cube needed to be iterated to create a three dimensional array of cubes (Revina, Zulkardi, Darmawijoyo & van Galen, 2011), in essence ‘packing’ cubes to create an identical solid. Given that only a single unit was provided, an efficient means of doing so would be to use a “spatial structuring strategy...to determine the number of cubes in terms of layers and then multiply...to obtain the total number of cubic units” (Revina et al., 2011, p. 129).

Students were provided with a solid wooden block ($4\text{cm} \times 4\text{cm} \times 4\text{cm}$), a single unit cube ($1\text{cm} \times 1\text{cm} \times 1\text{cm}$), a straight edge, a pencil and a piece of paper. The metric dimensions of

the solid were not provided and students were not told that it was a cube. The task required students to measure the volume of the solid using the smaller cube as a measurement unit.

The volume of the solid was 64 cubic units.

Figure 5.3 The question: Measure the volume of the block using the small cube as a unit

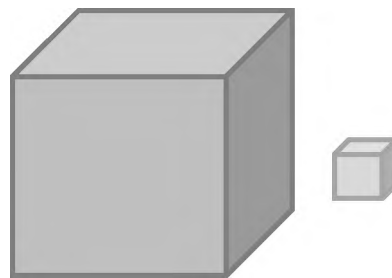

Figure 5.4 Student working on Task 2



5.4 TASK THREE: MEASURING VOLUMETRIC FLOW RATE

There were eighteen interviews conducted for Task 3. In this task, students were required to observe as water flowed from various holes in a cylindrical container and to calculate the average volumetric flow rate for each of four given situations. The diameter of the holes and

their positioning differed in each example. The pressure was not kept constant as the water flowed out.

An illustration of the cylindrical container used in Task 3 is provided in Figure 5.5. The relative diameters and positions of the holes can be seen on the illustration, as well as the linear scale used to calibrate the cylinder to show the 6 units of volume.

Figure 5.5 Cylindrical container used for Task 3

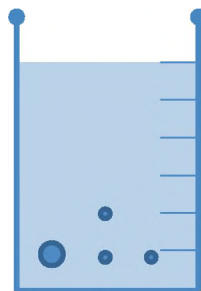

Figure 5.6 shows an image of the interviewer and a student as they complete this task. In the first frame, the student can be seen observing the water flow out of the container, and using a stopwatch to measure the amount of time it took. In the second frame the student is inspecting the container after the water has flowed out to determine the quantity that flowed out.

Figure 5.6 Student and interviewer participating in Task 3



There were four subtasks: the first pair of subtasks involved students calculating average volumetric flow rate over ten seconds, the second pair involved students calculating the same for a given volume. These will be described in the sections that follow.

5.4.1 Subtasks 1 and 2: Calculating average volumetric flow rate for a given period

In Subtask one, a hole with a diameter of 2mm was opened for a period of 10 seconds. Students were asked two questions:

- (1) What is the volume of water that flowed out in 10 seconds?
- (2) What is the average flow rate?

Figure 5.7 shows the front view of the cylinder indicating the position of the hole, and the side view when $time = 0\text{ seconds}$ and at $time = 10\text{ seconds}$. One can see that $2\frac{3}{4}$ units flowed out in 10 seconds.

Figure 5.7 Task 3, Subtask 1

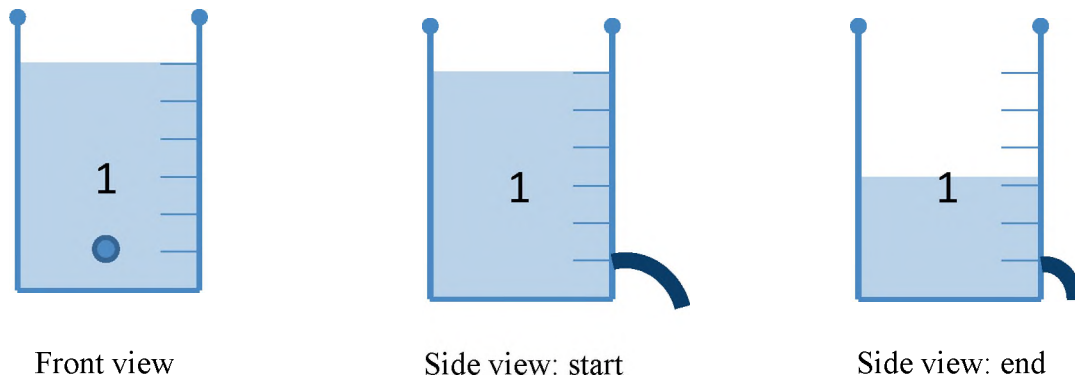

In Subtask two, a hole with a diameter of 1mm (half of that in Subtask 1) was opened for a period of 10 seconds. Before commencing with the task of measuring, students were asked what volume they predicted would flow out in ten seconds. Students were asked the same two questions:

- (1) What is the volume of water that flowed out in 10 seconds?
- (2) What is the average flow rate?

Figure 5.8 shows the front view of the cylinder indicating the position of the hole, and the side view when $time = 0\text{ seconds}$ and at $time = 10\text{ seconds}$. One can see that 1 unit flowed out in 10 seconds.

Figure 5.8 Task 3, Subtask 2

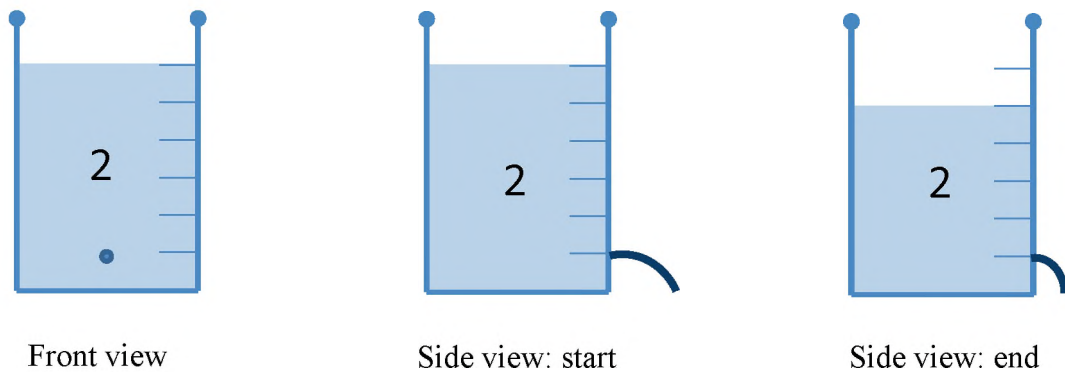

It is also apparent in both Figure 5.7 and 5.8 that the stream flowing out of the cylinder changed in shape from the beginning to the end of the 10 seconds. The pressure in the system was not constant, therefore as the height of the water in the cylinder decreased, so did the pressure. This resulted in the shape of the stream of water changing, reflecting a decrease over time of the volumetric flow rate. It was, however, the average volumetric flow rate that students were required to calculate, therefore attention to this aspect was not required.

5.4.2 Subtasks 3 and 4: Calculating average volumetric flow rate for a given volume

Subtasks 3 and 4 differed from Subtasks 1 and 2 in two important ways: two holes were now opened and the time was to be measured for a given volume that was to flow out.

In Subtask 3, two holes with a diameter of 1mm each were opened, and 4 units of volume were to be observed flowing out. These holes were positioned horizontally in relation to one another. Students were again asked two questions. For this subtask, these were:

- (1) How long did it take for 4 units to flow out of the cylinder?
- (2) What is the average flow rate?

In a similar manner to Subtask 2, before observing and measuring, students were required to make a prediction. They were asked to predict the length of time they thought it would take for four units to flow out.

Figure 5.9 shows the front view of the cylinder indicating the position of the holes, and the side view when $time = 0\text{ seconds}$; $volume = 6\text{ units}$ and when $volume = 2\text{ units}$.

Figure 5.9 Task 3, Subtask 3

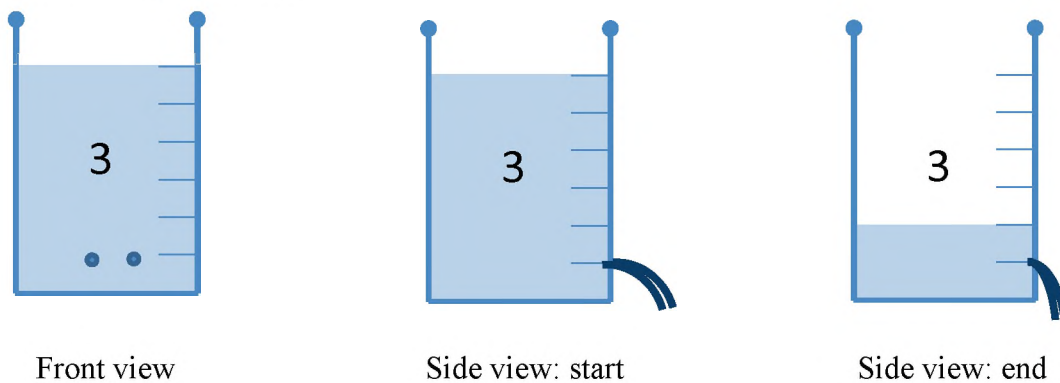

In Subtask 4, the two holes were identical in diameter to the two in Subtask 3, but were positioned vertically. After making a prediction regarding the length of time they thought it would take for four units to flow out, they were again asked:

- (1) How long did it take for 4 units to flow out of the cylinder?
- (2) What is the average flow rate?

Figure 5.10 shows the front view of the cylinder indicating the position of the holes, and the side view when $time = 0\text{ seconds}$; $volume = 6\text{ units}$ and when $volume = 2\text{ units}$.

Figure 5.10 Task 3, Subtask 4

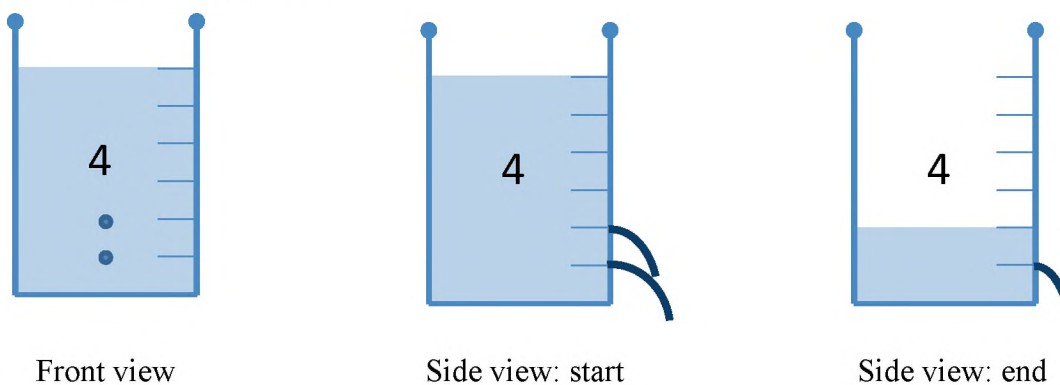

Figures 5.9 and 5.10 again show changes in the streams of water from the beginning to the end of the measuring activity. The difference was more pronounced in these subtasks than for Subtasks 1 and 2.

In Subtask 3 this was due to the fact that it took longer for a volume of 4 units to flow rate, and this increase in the length of the observation allowed the students to notice the change. For subtask 4 this was because when the holes were aligned vertically, the flow out of the top hole decreases and eventually comes to a halt during the period of observation. Students were asked to account for these changes at the conclusion of these subtasks.

5.5 TASK FOUR: COLLABORATIVE AREA MEASUREMENT TASK

Ten interviews were held in which students collaborated to complete a measurement task. Each interview involved one student who had participated in the earlier tasks in the research, and this student was invited to choose any other Level 2 classmate to join. The student whose engagement was analysed, was the student who had participated in the earlier tasks.

This altered the mediation situation slightly. Sign mediation was offered by the interviewer, as per the other tasks, but the peer, because of their direct involvement in the task, contributed at a tool and sign level. The analysis of these interviews is elaborated upon in Chapter 8.

This task required the calculation of area, but rather than the highly simplified but abstracted nature of the task in interview 1, a more complex and context-rich problem was posed. The task was designed to resemble a measurement task that may realistically be required in a workplace situation.

As with the previous task-based interviews, students' performance was dynamically assessed with the interviewer acting as a mediator. The interviews were video-recorded for later summary and analysis.

5.5.1 The question

Students were provided with an A3 map of a holiday resort and were asked to calculate the cost to build the resort. An A4 version of this map is included as Appendix P.

Figure 5.11 Map of holiday resort



Students were given the following card containing the context-based question and the essential information required to respond to it:

Figure 5.12 Information card

A building contractor has provided a quotation for constructing this resort. The buildings that need to be built include:

- *19 holiday houses*
- *The Bohemia Beach Bar and Grill restaurant*
- *The Blu Seafood Restaurant*
- *The Frigate Bay House (purple)*

The contractor calculates his quotation according to a price of R8500 per square metre (m^2).

What is the total that the contractor would charge to construct these buildings?

The scale of the map is 1:700

In addition to the map and the above card, students were provided with: a 30cm ruler; a 15cm ruler; paper; pencils; erasers; and a basic calculator.

Prior knowledge that was required for this task included the following:

- How to use a ruler to accurately measure length
- How to calculate the area of rectangles, triangles and circles
- How to calculate the area of composite figures
- How to use a scale to interpret a map
- How to calculate cost when provided with cost per unit

All of the above prior knowledge should have been school-met for these students.

5.5.2 Mediation

While mediation differed subtly for each pair, depending on their chosen approach to the problem, there were cards prepared with information that was anticipated to be requested. These cards acted as additional artefacts to which the students could refer while solving the problem and contained the formulae for calculating the areas of the basic shapes that appeared on the map. They were provided when it was judged that students were finding it difficult to proceed without this information.

Figure 5.13 Artefact cards containing area formulae

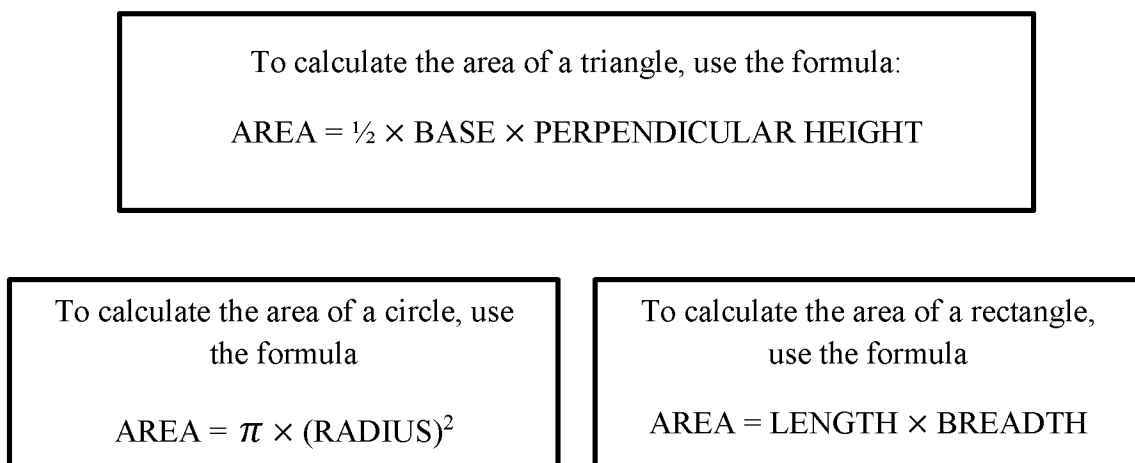

5.5.3 The interview process

The interview opened with a verbal description of the problem. Students were instructed to attempt to solve the problem without the interviewer's assistance, and informed that assistance would be available if they were struggling significantly at any stage.

There was particular mention made of the formulae that would be required in order to solve the problem. It was explained that they would only be provided after students had made an attempt to recall them.

In order to observe the capacity students demonstrated while solving the problem, as well as the amount and level of mediation required, minimal interruption of the students' process was crucial. In order to achieve this, certain errors were allowed to be carried forward to later stages of the problem. Interviewer mediation was delayed until the end of the interview in these cases. These errors were:

- The use of the diameter, rather than the radius, in the calculation of the area of the circular restaurant
- The use of a side of a triangle, rather than the perpendicular height, in the calculation of the area of the triangles forming the hexagonal restaurant
- The overlap of the rectangles added together to form the composite shape of the hotel building
- The exclusion of a rectangle when adding together the rectangles forming the composite shape of the hotel building

As with Tasks 1 to 3, the interview was concluded with instruction, for those students requiring it, regarding how one could arrive at the accurate solution. Mediation addressing these anticipated possible errors was delayed until this stage, and was then provided in order to allow the students an opportunity to correct these errors. This mediation was coded and included in the interview analysis.

The question was posed in such a way as to allow students to determine their own approach to the problem. Therefore, aside from the pre-determined guidelines described above, the decision to provide mediation was at the interviewer's discretion.

5.6 TASK FIVE: FORMAL WRITTEN TEST

A formal written test was used by the college lecturers as the instrument for assessing the students' ability to measure length, area and volume. This test is included as Appendix Q. The test assessed the following Subject and Learning Outcomes (DHET, 2011, p. 15):

TOPIC 3: SPACE, SHAPE AND MEASUREMENT

<u>Subject Outcome 3.1</u>	Measure and calculate physical quantities
Learning Outcome 3.1.2	Use symbols and Système International [SI] units as appropriate to the situation
<u>Subject Outcome 3.2</u>	Calculate perimeter, surface area and volume in two- and three-dimensional geometric shapes
Learning Outcome 3.2.1	Calculate the perimeter and surface area of the following laminas: square; rectangle; circle; triangle; parallelogram; trapezium and hexagon
Learning Outcome 3.2.2	Calculate the volume of the following geometric objects: cubes; rectangular prisms; cylinders; triangular prisms and hexagonal prisms

The test consisted of 16 questions. Eight questions required students to calculate the volume of various geometric objects, five required students to calculate the total surface area of geometric objects, two required the calculation of length, and one question required students to find the area of a two-dimensional surface.

Eight questions were accompanied by text which provided a context to the problem. Seven of these included a diagram representative of the object or lamina. The remaining eight questions involved the calculation of the volume and total surface area of three-dimensional objects represented only by diagrams.

The tests used for analysis were those written by students involved in any of the interviews. The total number of students who had participated in at least one interview amounted to 39. By this stage of the academic year, 27 students remained of this group, with the attrition due to specific contextual factors (see Section 4.4.1.3). The question paper was collected as well as the students' answer sheets. This allowed the researcher to view the students' calculations and solutions as well as the notes the students made on the question paper as they worked.

Students were instructed to attempt all questions and to show all calculations used to arrive at their solutions. A formula sheet, containing most of the formulae that were required for the calculations, was provided as an artefact for students to refer to during the test. This is the practice for all NC(V) mathematics assessments (DHET, 2011). This artefact is included as Appendix R.

5.7 SUMMARY

In this chapter, a detailed description of the five measurement tasks in which students engaged has been provided. The set-up of the various practical apparatus for the first four tasks has been shown, as well as the details of how to conduct those interviews. The written test has also been described and provided as an Appendix.

These details have been provided to support the brief description of the task-based interviews in Chapter 4, and to provide the level of detail required to contextualise the data presentation and analysis that follows in Chapters 6 to 9.

CHAPTER 6

PRESENTATION AND ANALYSIS OF DATA: INTERVIEWS 1 & 2

6.1 INTRODUCTION

In this chapter, data from the first and second task-based interviews will be presented and analysed. The process of summarising and analysing these interviews will be described and thereafter, data pertaining to the students' performance in the interviews will be presented.

6.2 PROCESS OF SUMMARY AND ANALYSIS

This section describes the process of summary and analysis for both Task 1 and Task 2. Each interview was video-recorded for later summary and analysis, as the researcher took the role of interviewer and mediator. A narrative of the interviews was constructed according to the process described in Section 4.5.2.1. The critical incidents emerging from these narratives are presented here, with the results of the iterative, constant comparison process of coding the mediation moments.

These critical incidents included moments of mediation, which were coded according to the level of mediation and special note was taken regarding what aspect of the task required this mediation. Pertinent excerpts from interactions between the interviewer and student were also transcribed, of which several are provided here as supporting evidence.

6.2.1 Summary and analysis of Task 1

It became clear, on observing students completing Task 1, that the task could be divided into three phases. Every student spontaneously completed the components of the task in a specific order. For the purpose of analysis, the task was therefore viewed as consisting of three phases based on this work. The phases were:

- Phase 1: arriving at a strategy to find the number of whole tiles contained within the surface without overlap, and determining the number of whole tiles contained within the surface (lower-bound strategy; see Figure 6.1)

OR

arriving at a strategy to find the number of tiles, both whole and partially covered, by the surface (upper-bound strategy; see Figure 6.2)

Phase 2: arriving at a strategy to calculate the area of the surface that remained after Phase 1, and determining the area of this remaining surface (lower-bound strategy; see Figure 6.1)

OR

arriving at a strategy to deduct from the number of tiles the area not covered by the surface (upper-bound strategy; see Figure 6.2)

Phase 3: adding the results from Phase 1 and Phase 2 (lower-bound strategy)

OR

subtracting the result from Phase 2 from the result from Phase 1 (upper-bound strategy)

Figure 6.1 Areas measured in Phase 1 and Phase 2 (lower-bound strategy)

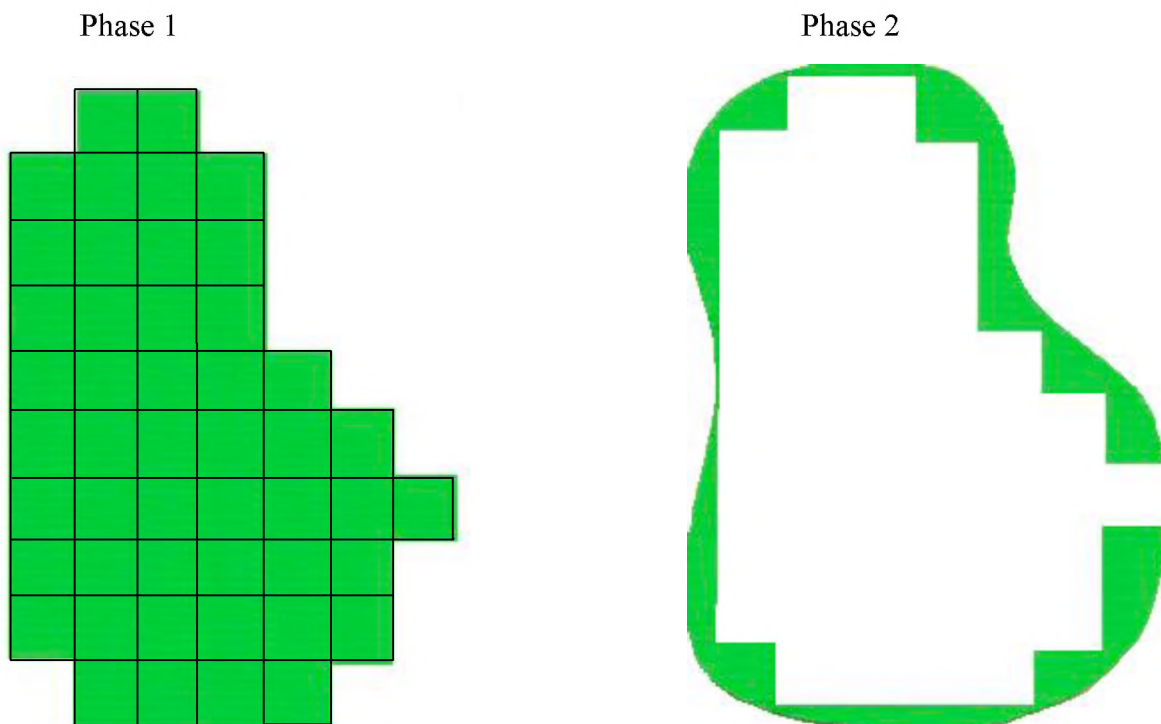
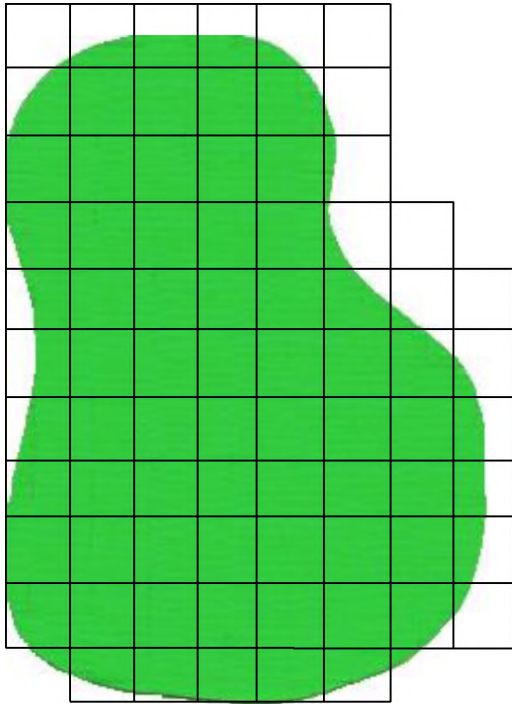

Figure 6.2 Areas measured in Phase 1 and Phase 2 (upper-bound strategy)



6.2.2 Summary and analysis of Task 2

As was the case for Task 1, students all completed the components of Task 2 in a similar manner. This allowed the task to be divided into two phases for the purposes of analysis. These phases were:

- Phase 1: working out how many unit cubes would create one layer of the cube (It was evident from the data that not all the students viewed this as creating one layer, others viewed this as covering the area of one surface)
- Phase 2: Multiplying the number of cubes required for one layer by the number of layers (alternately, those that viewed the unit cube as covering a surface, multiplied the number of cubes by the number of surfaces)

6.3 DATA PRESENTATION AND ANALYSIS: TASK 1

The presentation of the data concerning student performance in Task 1 has been divided into four main parts. The first data to be presented will be a general summary of the strategies taken by the students and the number of moments and level of mediation required per task phase.

Thereafter, detailed descriptions of the mediation provided for each of the three phases will be presented.

The work of every student completing this task is included as Appendix S.



6.3.1 General summary of task performance

This section provides a general summary, per student and phase, of the mediation moments during Task 1. It also outlines what strategies students chose in order to complete Phases 1 and 2.

A total of four identifiable strategies were followed by students in Phase 1, with only one student using a strategy that did not fit these categories. These included the use of a rectangular array [RA], the drawing of rectangles of decreasing size [RD], iteration of the tile in rows [IR], and iteration of tiles around the inside perimeter of the surface [IP]. An example of each of these strategies is provided in Table 6.1. Two examples are provided for RA as some students drew an array that covered the entire surface, while others drew an array that did not extend into the area to be measured in Phase 2. Each example provided in the table is accompanied by the cross-reference to the scanned work in Appendix S.

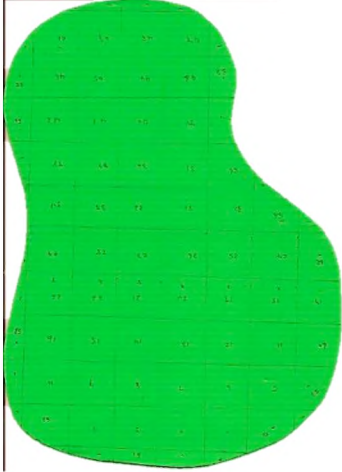
Table 6.1 Task 1, Phase 1 strategies

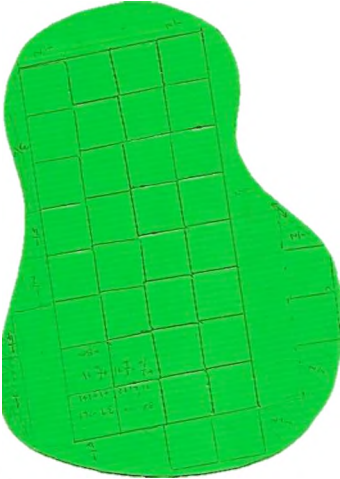
Strategy	Example	Description
Rectangular Array	 <p data-bbox="480 1843 754 1877">[Appendix S, no. 25]</p>	A rectangular array has been drawn to cover the entire surface [RA].

	 <p>[Appendix S, no. 1]</p>	<p>A rectangular array has been drawn to cover a central rectangular portion of the surface [RA].</p>
<p>Rectangles of decreasing size</p>	 <p>[Appendix S, no. 21]</p>	<p>A large rectangle has been drawn in the centre of the surface, and its area calculated with reference to the tile.</p> <p>Rectangles of decreasing size have been drawn in order to calculate the size of the remaining area [RD].</p>
<p>Iteration in rows</p>	 <p>[Appendix S, no. 16]</p>	<p>The unit tile has been iterated in horizontal rows that do not form an array of rows and columns [IR].</p>
<p>Iteration around inside perimeter</p>		<p>The unit tile has been iterated around the inside perimeter. Only one corner of each unit</p>

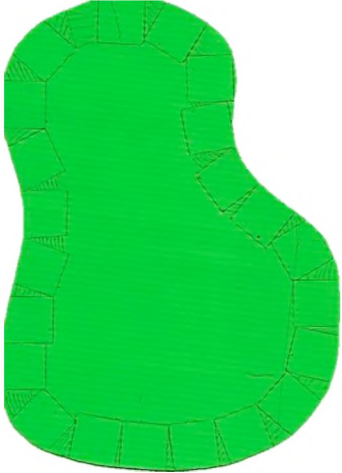

	 <p data-bbox="483 712 754 743">[Appendix S, no. 17]</p>	<p data-bbox="986 208 1390 320">touches the adjacent unit, with triangular gaps between units [IP].</p>
--	---	---

There were similarly a number of identifiable strategies for Phase 2. Several students drew rectangular arrays in Phase 1 that extended into the irregular area to be measured in Phase 2 [EA]. They then proceeded to label each partial unit with a rational number [LR] or a decimal [LD] or combined pieces mentally to form whole units [CW]. All of these were later added in Phase 3.

The same strategies were also observed for students who had not systematically extended their arrays, but with an additional category [PW] in which students added each remaining partial area as a whole unit. Table 6.2 shows examples of some of these strategies. Each example provided in the table is accompanied by the cross-reference to the scanned work in Appendix S.

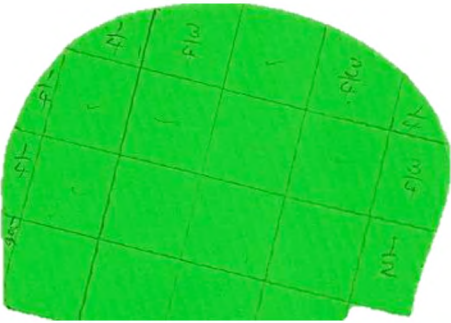
Table 6.2 Task 1, Phase 2 strategies

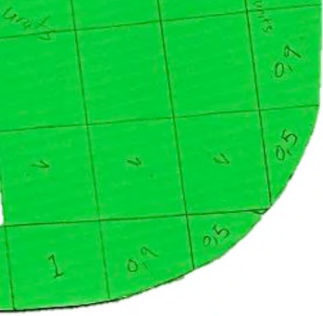
Strategy	Example	Description
<p data-bbox="204 1561 512 1682">Labelling partial units with rational numbers [LR]</p>	 <p data-bbox="539 1899 810 1930">[Appendix S, no. 11]</p>	<p data-bbox="1077 1561 1390 1765">The rectangular array drawn in phase 1 extends into the area to be measured in phase 2 [EA].</p> <p data-bbox="1077 1805 1390 1921">The partial unit areas are represented by rational numbers.</p>

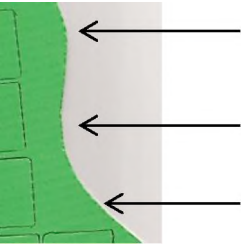
<p>Labelling partial units with decimals [LD]</p>	 <p>[Appendix S, no. 6]</p>	<p>The rectangular array drawn in phase 1 extends into the area to be measured in phase 2.</p> <p>The partial unit areas are represented by decimals.</p>
<p>Combining by sight to form whole numbers [CW]</p>	 <p>[Appendix S, no. 10]</p>	<p>The rectangular arrays in these examples do not extend into the areas to be measured in phase 2.</p> <p>The student has drawn borders around the areas she has counted as whole units.</p>
<p>Adding all partial areas as a whole unit [PW]</p>	 <p>[Appendix S, no. 20]</p>	<p>In this example the student added each of the areas indicated by the arrows as a whole unit to arrive at a solution of 3 square units for this area.</p>

Appendix T provides the general summary of task performance. It gives an indication of the number of moments of mediation per student and per task phase, as well as the level of this mediation, in the order in which this was provided. The strategy chosen by each student in Phases 1 and 2 is also included in this summary. Asterisks indicate moments in which mediation was provided to specifically address difficulties students experienced in working with fractions in this task. Students' work with fractions will be discussed in more detail in Section 6.3.3.2.

The codes used to describe the moments of mediation (as explained in section 4.5.2.4) are listed, in order from the lowest to highest level of mediation, below:

- A: no mediation
- B: reassurance
- C(m): prompt (method)
- C(c): prompt (concept)
- P(a): provision of artefact
- D(m): leading question (method)
- D(p): leading question (process)
- D(c): leading question (concept)
- E(m): instruction (method)
- E(c): instruction (concept)
- F(m): correction (method)
- F(c): correction (concept)

The emergent codes used in this task included [P(a)] and [D(p)]. Provision of an artefact [P(a)], in this task, involved the provision of more unit tiles. Leading questions related to process [D(p)] were provided where students halted at the end of Phase 1 as if having completed the task. For this task, the distinction between D(m) and D(p) was made as it was the process that halted. It was not the case that students did not know the method for proceeding with the calculation. This is, however, placed in the hierarchy as more explicit than method-level leading questions, as the confident halt in the calculation process has been taken to indicate more of a conceptual instability than uncertainty over a method.

6.3.2 Summary of work in Task 1, Phase 1

Every student started the task by first forming a strategy to count the number of whole tiles that would be required to cover the area and then executing this strategy.

This section will provide a summary of the strategies chosen by the students as well as the mediation offered during this task phase. Several samples of student work will also be presented within these discussions.

6.3.2.1 Strategies used in Phase 1

All students understood the need to subdivide the whole area with reference to the unit, but chose to do so in different ways. As summarised in Appendix T, these strategies included the following:

- RA: Drawing a rectangular array
- RD: Drawing rectangles of decreasing size
- IR: Iterating the unit in horizontal rows

IP: Iterating the unit around the inside perimeter

Figure 6.3 provides a summary of the frequency of use for each strategy.

Figure 6.3 Strategies used in Task 1, Phase 1

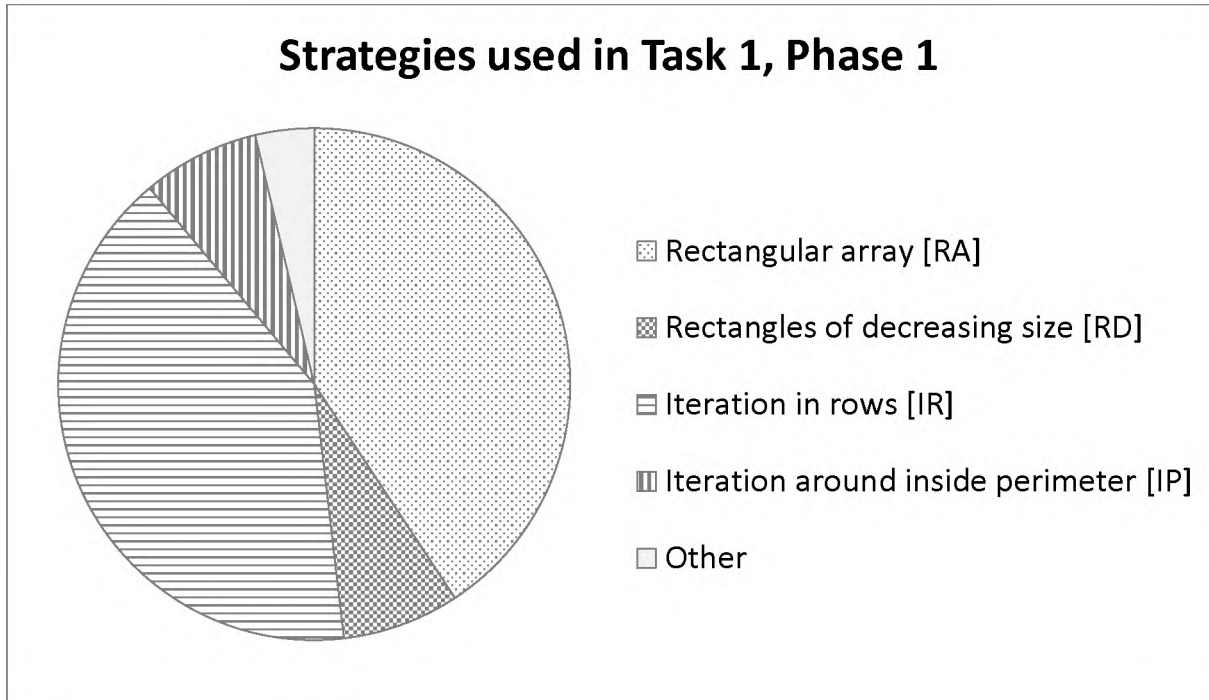

The use of a rectangular array of rows and columns [RA], which is the standard method to calculate the area of a rectangular surface (see Cavanagh, 2008) was used with the highest frequency. Only 2 students used the strategy of drawing rectangles of decreasing size [RD] in order to calculate the number of whole tiles. This was a form of strategy which utilised a rectangular array, but the array was confined to the rectangular area did not extend across the whole surface.

Equal to the frequency of RA was the number of times the strategy of iterating the unit in rows [IR] was used. This could also be viewed as similar to a rectangular array. In these cases however, the rectangles measured $1 \times x$ square units rather than consisting of multiple, aligned rows and columns. While this strategy did not match the standard method that students would have met in schools, it was an efficient means with which to calculate the area of this irregular surface. It had the effect of maximising the number of whole units that could fit along each horizontal row, and therefore minimised the area per row that remained to be calculated in phase 2.

According to the trajectory proposed by Cavanagh (2008) this method would be viewed as being of a lower order, however, due to the advantages this method offered in this specific example, it is possible that it was used by some students who could use the array method, and may have done so had the surface been a rectangular.

The least efficient method was that of iterating around the inside perimeter. It represented a method of subdividing the surface in terms of the unit tile, but the gaps left between the tiles meant that the surface area that remained to be calculated in phase 2 was much larger, and consisted of a multitude of small areas. This would have negatively impacted on the accuracy of the area measurement, as more estimation was required.

As the students reached the end of this phase, they needed to arrive at a count of the number of whole units that could be fitted into the area. It was noticed that 24 of the 27 students interviewed counted in 1s to arrive at the total. Only Mzwakhe, Malume and Sipehelele used multiplication to assist them in calculating at least part of the total. In doing this, these three demonstrated the use of the (school-met) multiplicative relationship between the number of rows and columns of units and the area of the surface. The remaining 8 students who had made use of a rectangular array of rows and columns counted in 1s to arrive at the total.

One student, Sipehelele, chose to use an upper-bound strategy, classified as 'other' in Figure 6.3. His work is shown below.

Figure 6.4 Strategy type: Upper-bound

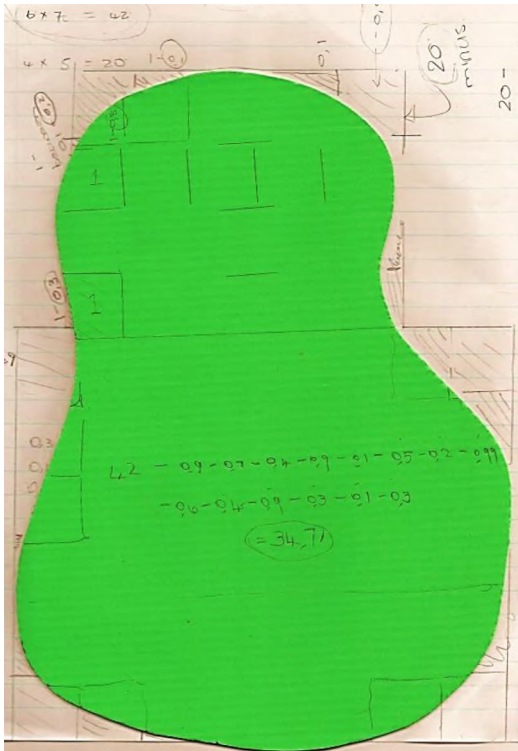

He worked with a rectangular array of columns and rows (although incompletely drawn), but did so in a different manner to the other students interviewed. While those students chose to subdivide the area into unit tiles and then add these, Siphelele chose to draw two regular rectangles around the surface and then subtract the excess area, thus using an upper-bound strategy.

While 27 students completed this task, only 5 different strategies were used in Phase 1. This suggests that there exist similarities among these students with regard to their measurement conceptualisations regarding area.

6.3.2.2 Mediation provided in Phase 1

There were students who required reassurance [B] as they decided how to start the task. This was provided, but was the maximum level of mediation any student required for the strategy-formation portion of Phase 1. Once the students started working with their chosen strategy, mediation of all levels was available where requested or necessary.

Figure 6.5 shows the number of moments of mediation, and their level, used in Phase 1 of this task. The codes used are those listed in section 6.3.1.

P(a), or the provision of an additional artefact, was not one of the original mediation categories built into the design of the task-based interviews. The category was created during the process of constant comparison across all four interviews (see Section 4.5.2.2). Only one student required this form of mediation in task 1, but across all interviews there were many such examples which necessitated revisiting the classification for every interview.

Where artefacts were provided as an act of mediation, this was initially coded as a conceptual level prompt [C(c)]. When it was noticed that the number of such moments was inflating the number of moments of C(c), the question arose as to whether this “large, amorphous categor[y]” (Wellington, 2015, p. 263) could be split. The decision was made to create the distinction, with P(a) being considered less implicit than C(c). The provision of a physical artefact was conceptualised as being of greater assistance to students than other prompts [C], but as no demonstration of its use was provided, it was less explicit than a leading question [D].

The first column on the graph (representing code A), does not reflect the number of moments in which no mediation was required. It shows the number of students for whom no mediation was required. It is included on the graph for the sake of the discussion that follows.

Figure 6.5 Mediation in Task 1, Phase 1

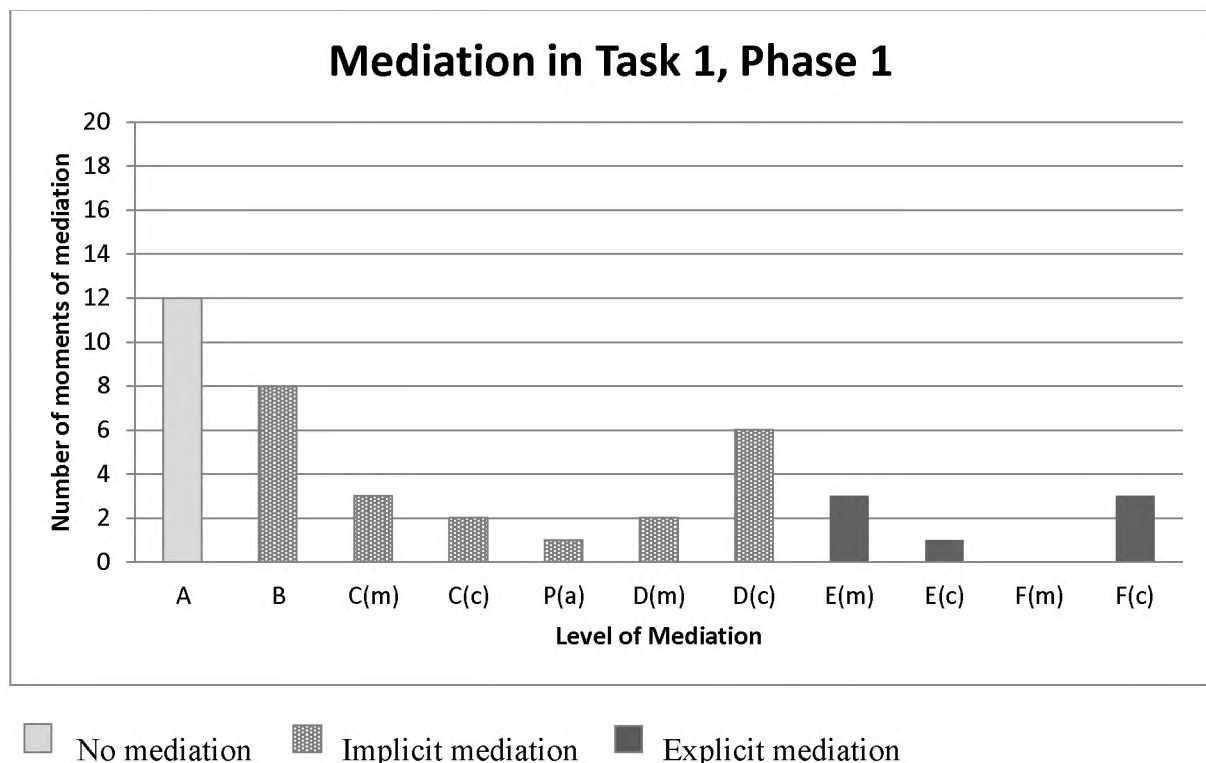

Twelve students were able to arrive at a strategy to find the number of whole tiles contained within the surface, and to count these, with no mediation from the interviewer. Twenty-nine moments of mediation were required for the remaining 15 students. For these students, the majority of the mediation provided was implicit, most of which was to provide reassurance to students that their decision to subdivide the surface was an appropriate first step in the task.

Ndileka required 7 of these 29 moments of mediation, four of which were at the conceptual level. One student required three moments of mediation, five required two moments, and nine students required only one moment of mediation. Ndileka therefore contributed the most to the final count. The mediation she required included the provision of additional artefacts [P(a)] in the form of extra unit tiles. She was the only student to require this form of mediation in this task.

She started the task by creating small 4×4 rectangular arrays, outlined in Figure 6.6 by the dashed lines. This was done by iterating the single unit tile. After offering a conceptual prompt [C(c)], a conceptual leading question [D(c)] and method-level instruction [E(m)], she was offered additional tiles. These were provided with conceptual instruction [E(c)].

Figure 6.6 below shows her work subsequent to the provision of these artefacts.

Figure 6.6 Student work: Ndileka

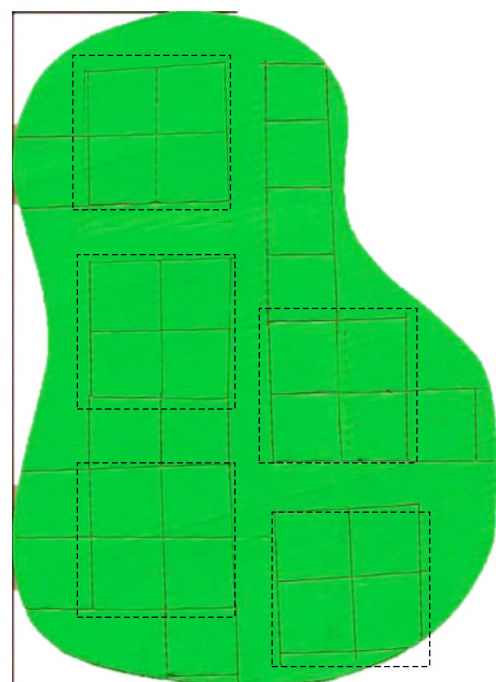

There was evidence that she now understood the need to close the gaps in the iteration, although this was not done consistently. The task was abandoned in favour of using the interview to provide general instruction about the concepts underlying area measurement.

6.3.3 Summary of work in Task 1, Phase 2

As students moved into Phase 2 of this task, there was a need to decide on a strategy for calculating the area either remaining to be included or in excess after Phase 1 (see Figures 6.1 and 6.2). A summary and description of these strategies will be provided, followed by a discussion of the mediation offered during this phase.

6.3.3.1 Strategies used in Phase 2

Table 6.2 provides a description of the strategy types used in Phase 2 of task. These were:

- LR: Labelling partial units with rational numbers
- LD: Labelling partial units with decimals
- CW: Combining partial units mentally to form wholes
- PW: Adding each partial area as a whole unit

In most cases (16 out of 27) students had drawn a rectangular array in Phase one that extended into the area to be measured in Phase 2 [EA]. The remaining students needed to decide on a different strategy to subdivide the area. Figure 6.7 provides information regarding the frequency of use of these strategies.

Figure 6.7 Strategies used in Task 1, Phase 2

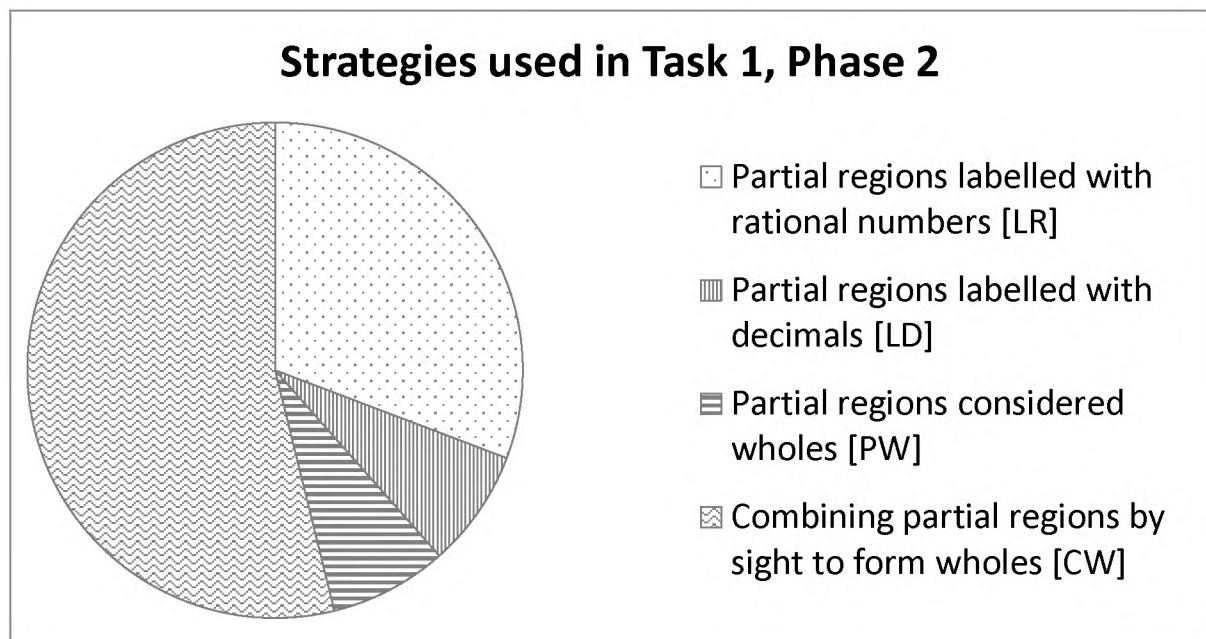

The strategy used with the highest frequency was that of combining partial regions by sight to create whole units [CW]. In this manner students minimised the need to use rational numbers in their calculations. The reason for this choice could have been due to these students' confidence in their ability to estimate without using symbolic representations such as rational numbers, their judgment that this strategy would be suitable for the level of precision required for this task, or a lack of confidence in their ability to work with rational numbers. As half of the students who chose this technique did so after first trying to use rational numbers, it is reasonable to assume that the latter was the case for most.

Two students counted each partial region as a whole unit (a conceptual error) which led to the need to provide conceptual correction [F(c)] in Phase 3 when they added these units to arrive at their final solution.

Only 2 students opted to use decimal notation to represent the sizes of the partial units, while 8 selected rational numbers as a symbolic representation for these units.

6.3.3.2 Mediation provided in Phase 2

In Phase 2, students required a much larger number of moments of mediation than in Phase 1. The majority of students required a form of leading question to enter this phase [D(p)]. This was conceptualised as being of a level between D(m) and D(c). It was a process-oriented

leading question, which was either due to the student not recognising the need to include the area not covered by whole units (a conceptual issue) or not knowing how to go about measuring it (a method issue). Neither D(m) nor D(c) were appropriate and therefore the existing categories were not exhaustive and an additional category was required. D(p) was therefore taken to be an intermediate-level leading question and an additional category was created to account for it.

Figure 6.8 provides data regarding the frequency of use of each level of mediation. The codes used are the same as those listed in section 6.3.1, and as with Figure 6.5, the frequency of ‘A’ concerns the number of students who did not require any mediation, rather than the number of moments of mediation as with the rest of the graph. It is included for its contribution to the discussion that follows the figure.

Figure 6.8 Mediation in Task 1, Phase 2

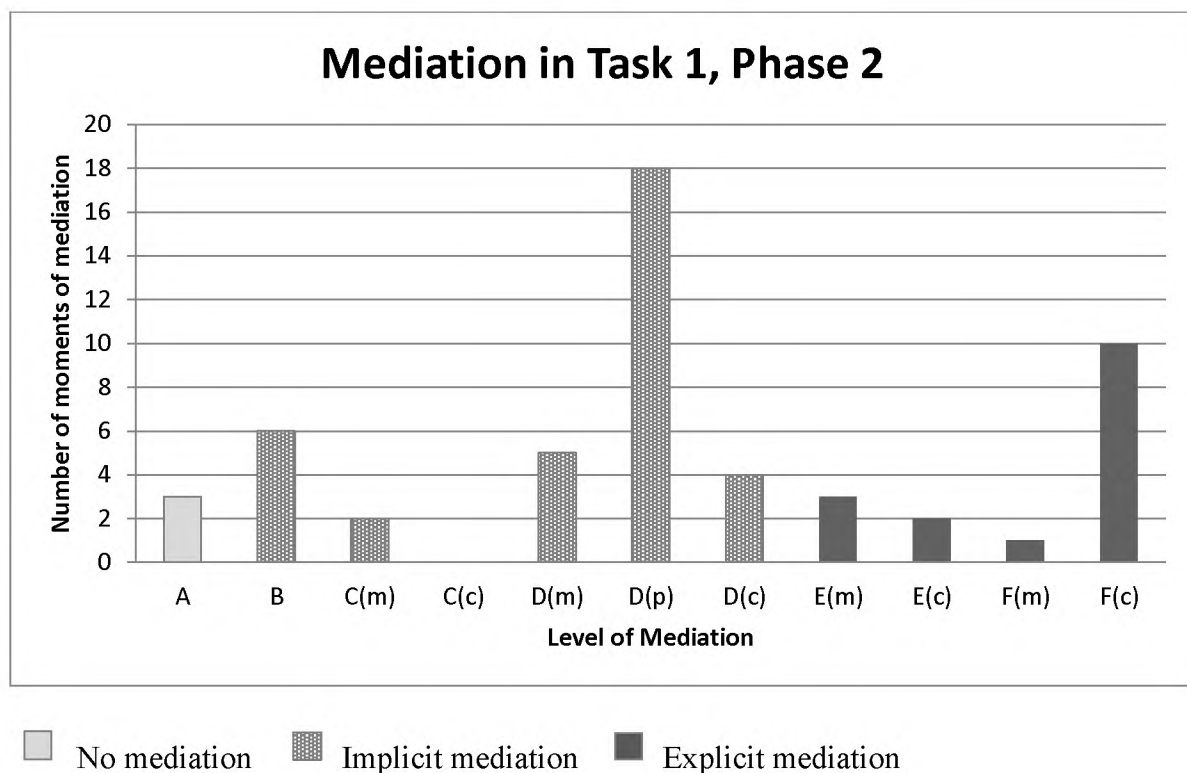

In contrast to Phase 1, only 3 students completed Phase 2 without the need of any form of mediation. All three students (Nobuhle, Aviwe, and Mbulelo) had drawn a rectangular array that covered the entire surface area in Phase 1. Nobuhle and Mbulelo had then chosen to combine partial units mentally to form whole units [CW], and Aviwe had selected to label the partial areas with decimals [LD].

All of the students who made use of rational numbers as their strategy for this phase required mediation regarding their use of fractions. This was for a variety of reasons ranging from poor estimations to whole number bias.

Figure 6.9 shows two examples of whole-number bias. In the example on the left, the student has provided a reasonable estimation of the two pieces labelled as $\frac{1}{2}$, but for the larger piece has increased the denominator to 3, and has kept the numerator as 1. The example on the right shows a similar error. The estimation of $\frac{1}{4}$ for the smaller piece is reasonably accurate, but this student has also increased the denominator for the rational number representing the bigger piece and has left the numerator as 1. These students had difficulty with the rational number symbolic representations for the size of these pieces.

Figure 6.9 Whole number bias: an example



[Appendix S, no. 6]

The student's work shown in the example in Figure 6.10 displays an unstable or emerging knowledge of how to use rational number notation. The piece labelled as $\frac{1}{4}$ is larger than the piece labelled as $\frac{1}{5}$, therefore the student's decision to increase the denominator is conceptually sound. However, when comparing the piece labelled as $\frac{1}{7}$ with that labelled $\frac{1}{5}$, it is the latter section that is smaller, and it should therefore have a larger denominator than the former.

Figure 6.10 Evidence of unstable or emerging knowledge



Two students' work stood out in this phase of the task, as they each took a unique approach to the challenge of measuring the irregular area remaining after Phase 1: Neliswa and Malume.

Figure 6.11 shows Neliswa at work. She chose to iterate the unit tile in rows in Phase 1, and after this process chose to physically cut away the remaining area. The resulting pieces were physically recombined to construct an area which could again be covered by whole tiles.

Figure 6.11 Student work: Neliswa

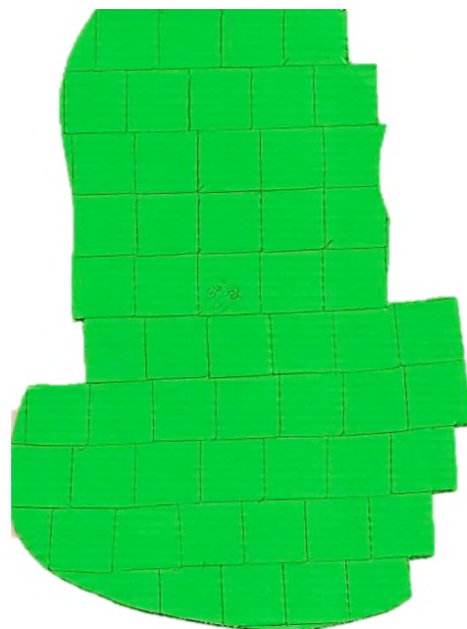

Malume devised an integration-like strategy to work with the partial areas. His work is shown in Figure 6.12. In Phase 1, he started by drawing a large rectangle in the centre of the surface, and measured the length and breadth of this rectangle with reference to the unit tile. He then

multiplied to arrive at the area of this rectangle. Upon realising that more whole units could fit onto the surface, he proceeded to draw rectangles of decreasing size that held whole units.

Malume continued with this strategy as he seamlessly entered Phase 2. He started to draw half units and quarter units to fit into some of the smaller areas. When he started needing to draw $\frac{1}{8}$ th units, he decided that an easier method would be to estimate by sight and combine mentally to form whole units. The fact that he chose to initially take an integration-like approach is noteworthy as this was not a previously encountered method he would have met in school (Malume's highest grade of mathematics passed was Grade 11 Standard Grade), and he had last been in a school mathematics classroom eighteen years prior to this interview.

Figure 6.12 Student work: Malume



As with Phase 1, it is notable that of the 27 students completing the task, only 4 different strategies were used. This again suggests common ground regarding the measurement conceptualisations these students have, despite being such a heterogenous group.

6.3.4 Summary of work in Task 1, Phase 3

Task Phase 3 was far less demanding than Phases 1 and 2. The only requirement was to combine the results from Phases 1 and 2 to arrive at a final measurement for the area of the surface.

Three students did not complete the task. In the case of Ndileka (as discussed in section 6.3.2.2) this was the result of a decision taken by the interviewer to abandon the task in favour of using the opportunity for learning. For Andile and Sipehelele, the time available for the interview was limited. In these cases Phase 3 was completed in collaboration with the student.

Thirteen students managed to complete this with no need for mediation, but for those who did require mediation, this was mostly at an explicit level. Figure 6.13 shows the number of moments of mediation required, as well as their level.

Figure 6.13 Mediation in Task 1, Phase 3

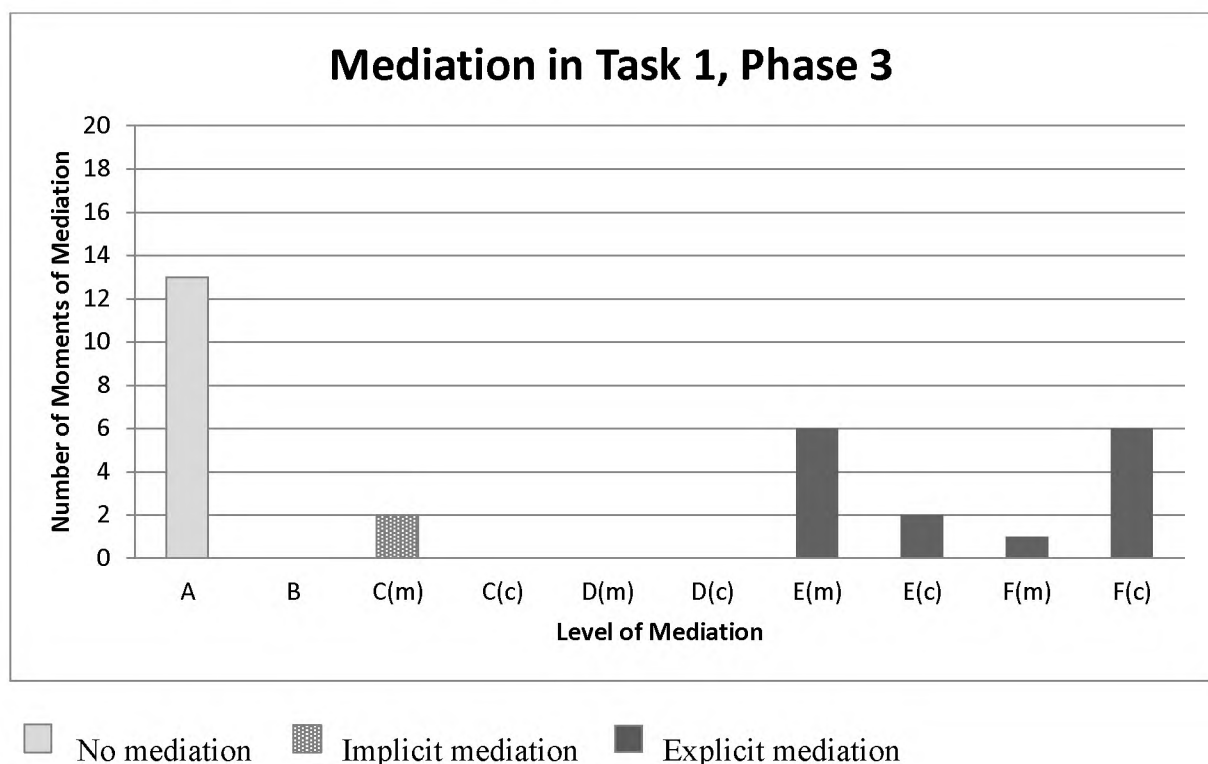

There were 11 students who required some form of mediation for this phase. Of those, 7 students required mediation with regard to the use of fractions, particularly with regard to how to add them. Students did not know how to complete an addition sum that included rational numbers, and required explicit mediation in order to do so.

6.3.5 Summary

This section presented the results of the data analysis for the first task-based interview. It was noted more than once that despite the number of students who participated, the fact that only

five and four strategies were used for Phases 1 and 2 respectively, suggests that there are shared characteristics between the students with regard to their measurement conceptualisations.

6.4 DATA PRESENTATION AND ANALYSIS: INTERVIEW 2

This section will comprise four main parts. The first data to be presented will be a general summary of the work done by the 26 students who participated in this task, and the number of moments and level of mediation required per task phase. Secondly, there will be a short discussion of the definitions students provided in response to the question “what is volume?” Thereafter, detailed descriptions of the mediation provided for each of the two phases will be presented.

6.4.1 General summary of task performance

This section provides a general summary, per student and phase, of the mediation moments during Task 2. In addition, the students’ solutions to the task have been summarised.

All students of their own accord completed the components of Task 2 in a similar manner, which allowed the task to be divided into two consecutive phases for the purposes of analysis. These phases included:

- Phase 1: working out how many unit cubes would create one layer of the cube
- Phase 2: determining the total number of cubes required for the solid constructed

Appendix U provides the full summary of student performance in this Task. The moments of mediation are listed in the order in which they were provided. The mediation indicated in italics is that which was provided subsequent to the student arriving at a solution they felt was accurate. These solutions are listed in the final column.

In the case of two students (Ndileka and Malusi) the task was abandoned in favour of using the interview to facilitate learning about the concepts underlying volume measurement. This decision was taken at the interviewer’s discretion when it was observed that neither student was managing to make progress in solving the problem through the mediation provided.

6.4.2 Student definitions of volume

Volume needed to be understood to be the amount of space that an object occupies, and the size of the volume was to be reported in terms of the size of the unit cube. Several students were unable to provide a verbal explanation of their understanding of volume, but 16 managed to respond with more than simply “I can’t explain”.

Certain students, while not necessarily able to provide an accurate definition, did reveal that they understood it was distinct from the attribute of area. These included students who provided solutions that indicated volume as well as several who provided solutions in terms of surface area.

The definitions provided by some of those who gave answers in terms of cubic units are listed below. These students all provided definitions that indicated an attribute in three dimensions:

- Mzwakhe: I think volume is...capacity...the insides
- Nomsa: [gestures with finger tracing edges equivalent to the length, breadth and height of the cube]
- Aviwe: The weight of the box?...it’s the shape of it...
- Linda: lengte, breedte, hoogte (length, breadth, height)
- Malume: um...space

Of these students, only Malume was able to complete the task without the provision of extra cubes [P(a)] which allowed the students to partially build an identical block, thereby exposing the attribute of ‘volume’.

Samkelo and Mbulelo, who both obtained the correct solution of 64 cubic units, provided definitions that were not clearly indicative of an understanding of the three-dimensional nature of volume. Mbulelo did not require the provision of extra cubes in order to complete the task, which indicated that he did have an accurate conceptualisation of the attribute of volume independent of whether or not he was able to verbalise this understanding. Samkelo, however, required extra cubes [P(a)] in order to start measuring in three dimensions. Their definitions appear below:

- Samkelo: The distance from there to there [traces one edge with his finger]...and all of it [holds fingers at width of the traced edge and places them on each of the top four edges]...all of it...

Mbulelo: [looks up and talks softly to himself] three, um, squared

Several students who provided an answer in terms of surface area had provided definitions that showed they understood volume to be distinct from the 2-dimensional attribute of area. These are listed below:

Nobuhle: I think volume is the weight of the thing

Andiswa: length... [long pause]... height... width

Babalwa: the actual size [creates an enclosed space with his hands]

Andile: we are talking about the sizes [circular gesture in air around the cube]

Siphelele: the size [holds hand out as if holding an object]

Sisipho, who provided the solution of 64 square units, mentioned only length and breadth in her definition. Given that her solution was an expression of surface area, this definition hinted at the possibility that she conceptualised volume as being a 2-dimensional attribute of a 3-dimensional object.

Sisipho: [makes a circular gesture with her pen in the air] the size...length...breadth...length breadth

Ndileka's definition also hinted at a similar understanding of volume. She defined volume as "they have the same sides". As the solid was a cube, and therefore had 6 identical surfaces, it is a strong possibility that it was the case that she had similarly conceptualised volume as a 2-dimensional attribute of a three-dimensional object.

Thandiwe, who also provided an answer of 64 square units, was unsure of how to define volume and admitted to needing to guess after the attempt: "it's the number of [traces finger around three of the top edges]... I think".

The apparent contradiction between the students' definition of the attribute of volume and what they proceeded to measure signifies a disjuncture between how they had conceptualised the attribute and how they understood it should be calculated. It provides evidence that their understanding of the attribute of volume was not yet fully formed.

6.4.3 Summary of work in Task 2, Phase 1

In Phase 1, students did preliminary work that prepared them to calculate the volume of the solid with reference to the unit cube. All 26 students worked similarly in this phase. Students mapped out one surface of the cube with either a 4×4 rectangular array (21 students) or by iterating the unit cube along the length and breadth of one surface (5 students) and multiplying to obtain the number of cubes required to form one layer.

At this stage of the task it was not yet possible to separate those students who understood the solution of 16 cubes to be one layer of the solid, or the area of the covered surface.

Figure 6.14 shows the number of moments of mediation required by the students in order to arrive at the solution of 16 units after mapping one surface of the cube. Column A, as with the previous graphs in this chapter, does not reflect the number of moments, but rather the number of students requiring no mediation.

Figure 6.14 Mediation in Task 2, Phase 1

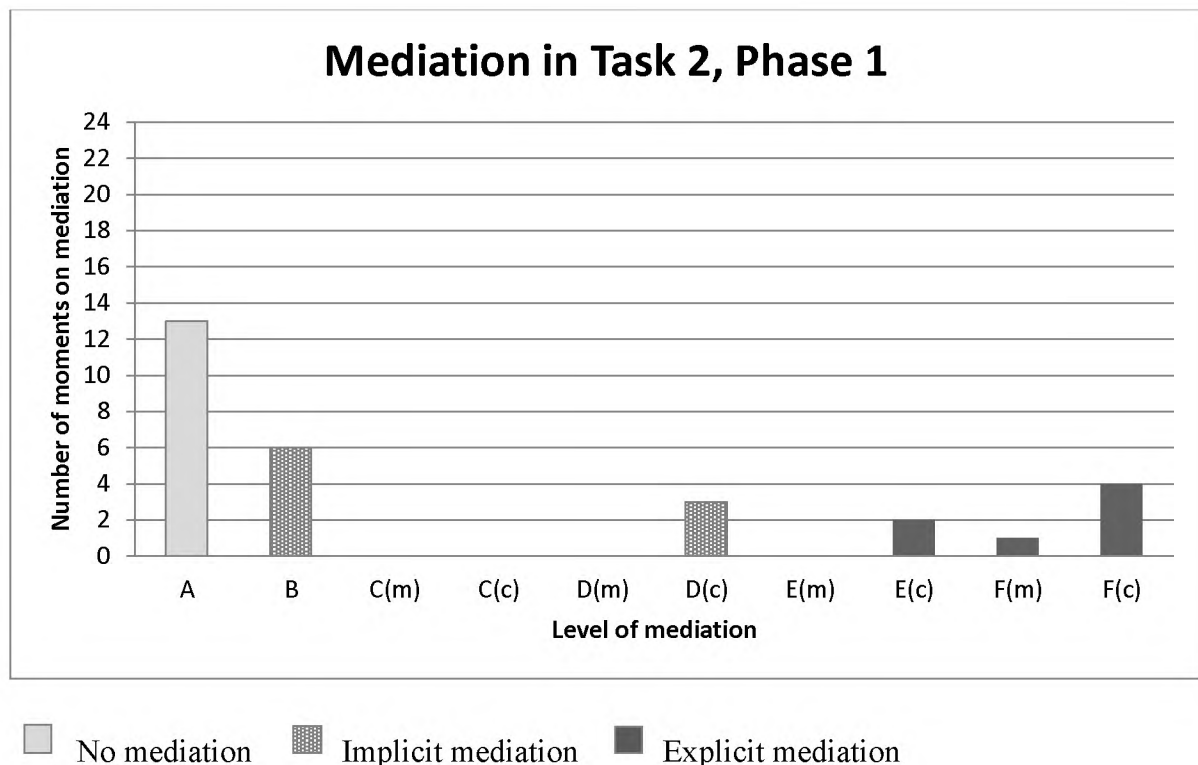

Half of the students were able to complete phase 1 without mediation. For the remaining 13 students, 16 moments of mediation were required, most of which were implicit. Five students required only reassurance [B] in order to proceed with their work in this phase. This is possibly

due to the inability of the interviewer at this point to observe whether the student was mapping out a preliminary measurement to calculate surface area or volume.

Malusi required the most mediation for this phase. He started the phase requiring instruction at a conceptual level [E(c)] after tracing around the cube to map out the surface while leaving large gaps. As a result he obtained an array of 3×3 units.

A second moment of instructions [E(c)] was required when he then proceeded to eliminate the gaps between the units, but left gaps instead on the outside of a new array of 3×3 units (shown in Figure 6.14). After declaring “the volume is 9”, conceptual level correction [F(c)] was provided.

Figure 6.14 Malusi: rectangular array

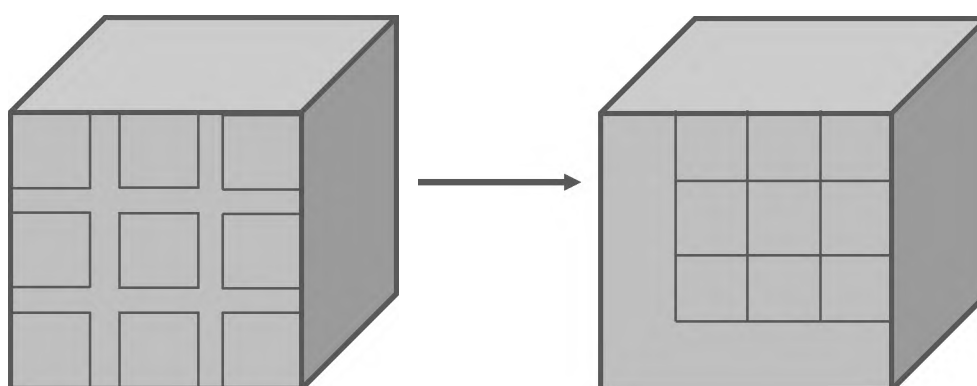

Despite drawing rectangular arrays in this phase, it was interesting to observe that only 5 students either counted in 4s or calculated 4×4 to arrive at the solution of 16 units for this phase. The remaining students counted in 1s.

6.4.4 Summary of work in Task 2, Phase 2

All students ended Phase 1 with an answer of 16 to work with in Phase 2. It was in this phase that it became clear that students had not all understood 16 to be the number of units required to form one layer of the solid. They had rather understood it to be that 16 units were required to cover one of the surfaces of the solid.

In order to address this, the mediation that was offered was to provide students with an extra 15 unit cubes in order to help them to visualise the layer that these 16 cubes would create. Only 4 of the 26 students were able to complete the task without this mediation.

Table 6.3 shows a summary of the solutions students provided for this task:

Table 6.3 Student solutions to Task 2

SOLUTIONS	Number of students
Volume correct (64 cubic units)	9
Volume of 3 layers (48 cubic units)	2
Area of 6 surfaces (96 square units)	7
Area of 4 surfaces (64 square units)	6
Could not be completed	2

Two of the students, Mzwakhe and Nomsa, who worked with volume subsequent to the provision of extra cubes, arrived at the incorrect solution of 48 cubic units. On questioning the students it became clear that they had calculated how many more cubes would be required to build the solid. Brief method-level instruction [E(m)] allowed them to see that the solution should have been 64 ($16 + 48$).

Mthobeli and Mbulelo made use of the formula to calculate the volume of a cube. They multiplied the length and breadth of the cube that they had established during Phase 1, by the height of the cube, which they measured in this phase. They arrived at the correct solution of 64 cubic units.

Twelve students calculated surface area rather than volume. The answers obtained by these students were either 64 square units or 96 square units. Those obtaining 64 as their solution indicated that they had added the surface areas of the four vertical sides of the solid. Those obtaining 96 units as their solution had calculated the total surface area for the object.

Should the question have asked for the total surface area, these students would have been correct. It was interesting, therefore, to note that of the 7 students who gave 96 as the solution, 5 remained adamant that their solution was correct and unconvinced that only 64 cubic units would build a solid of identical volume. A full cube had to be constructed using 64 units for these students to become convinced. None of the students who had provided 64 square units as the solution required this level of convincing that 64 unit cubes would be required to build the solid.

Figure 6.16 shows the number of moments of mediation provided in this phase, and the level of this mediation. Column A reveals that only 4 students were able to complete phase 2 of this task without mediation.

Figure 6.16 Mediation in Task 2, Phase 2

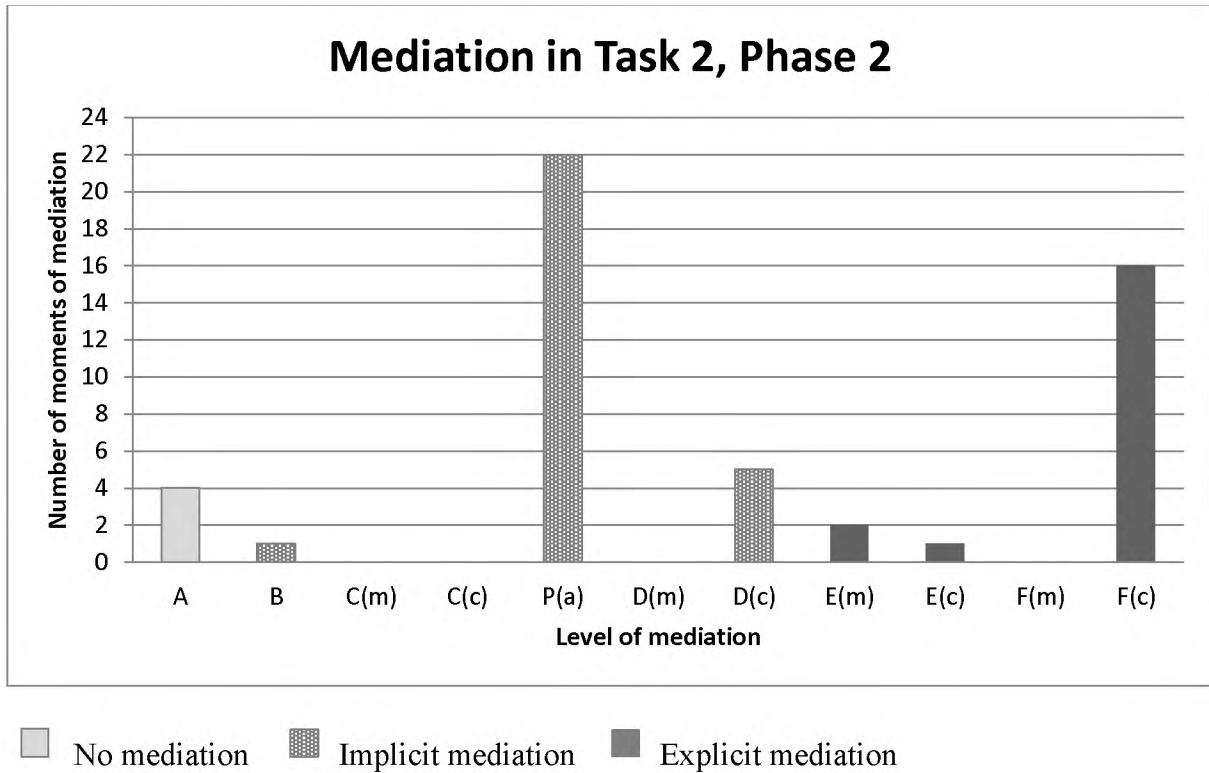

It is clear from the graph that the type of mediation that was provided with the highest frequency was P(a) (22 moments). The category with the second highest frequency was F(c). Sixteen moments of conceptual-level correction were required. These were all provided to students who had provided a solution in terms of surface area.

6.4.5 Summary

Task 2, as was the case for Task 1, provided evidence of a large number of students demonstrating similar understandings, or misunderstandings, regarding the concept of volume. It reveals clear areas of stable and emerging conceptualisations, as will be discussed in the following section.

6.5 STABLE AND EMERGING CONCEPTUALISATIONS

In order to respond to Research Questions 1 and 2, students' performance in Tasks 1 and 2 need to be considered in terms of what conceptualisations have been evident, and whether these are stable or emerging. As noted, the small number of strategies used relative to the large number of students completing the tasks suggest that there may be common conceptualisations held by a number of students.

In addition to attempting to provide answers to the first two research questions, further insights which have contributed to the major findings of this research are provided in this section.

6.5.1 Stable conceptualisations

During Task 1, the students, with the exception of Ndileka, were able to demonstrate that they held a stable and accurate conceptualisation of area. The evidence in this regard lay in their ability to arrive at a strategy to 'cover' the surface with unit tiles and to recognise the need to 'count' the number of tiles that would be required to do so. The strategies varied in their effectiveness and efficiency, but were nevertheless true to the concept of area.

In Task 1, Phase 2 many students opted to combine the partial blocks remaining after their lower-bound strategy to count whole units by sight and to estimate which areas could be combined to form a whole. This was done exceptionally well, with these students obtaining the most accurate measurement for this area. This is indicative of a stable conceptualisation of the standard unit used in the task (Joram et al., 2005).

Students had trouble with Task 2, initially with verbalising their understanding of volume, and then in confusing the concept of volume with that of surface area, which is one of the common areas of difficulty identified by Tan-Sisman and Aksu (2015) in their research with Grade 7 learners. For most, an explanation of their error was sufficient for them to be reminded that these are two distinct attributes of objects, but there were students who required substantial convincing before conceding that their solution was not correct.

What did appear relatively stable, however, was the knowledge that a formula for the calculation of volume is *length* \times *breadth* \times *height*. This was stable enough in their minds that it was the definition that many provided when asked to define 'volume'.

6.5.2 Emerging conceptualisations

There was evidence of instability in students' conceptualisations of rational numbers when they worked with them to calculate the area in Task 1, Phase 2. Whole number bias was the most frequent type of error for those students electing to use fraction notation. Students were responsive to mediation in this regard, however, indicating that the accurate conceptualisation is emerging.

6.5.3 Additional insights

It was enlightening to observe the stability of the misconception that volume and surface area are terms that refer to the same attribute of an object. As Tall (2013a) argues, met-befores can either be supportive or problematic, and this is an example of one which is hindering the learning of these students. Coupled with the fact that most were defining the attribute by stating the formula with which to calculate the measurement, and this for only one type of object, this hints at problematic met-befores regarding the link between the embodied world and the symbolic formal world regarding the concept of volume.

6.6 SUMMARY

In this chapter, data from Tasks 1 and 2 were presented and analysed according to moments of mediation, levels of this mediation, and where in the tasks this mediation was required. This analysis has permitted a number of preliminary answers to research questions one and two to be made. These will be further discussed in Chapter 10 where the results of all Tasks are considered together.

CHAPTER 7

PRESENTATION AND ANALYSIS OF DATA: TASK 3

7.1 INTRODUCTION

Data from the third task will be presented and analysed in this chapter. Students were required to measure flow rate in this interview, in a series of four subtasks. Eighteen interviews were conducted. A detailed description of the task was provided in Chapter 5. In this chapter, the process of summarising and analysing the interviews will be provided and thereafter, the data pertaining to the students' performance in the interviews will be presented. The chapter closes with a discussion of the stable and emerging conceptualisations, as well as additional insights, that came to light during this analysis.

7.2 PROCESS OF SUMMARY AND ANALYSIS

As with interviews 1 and 2 each interview was video-recorded for later summary and analysis. Whereas interviews 1 and 2 involved relatively little dialogue between interviewer and student, interview 3 required a lot more verbal interaction. Due to the practical set-up of the task (the cylinder and the stopwatch needed to be used simultaneously), the interviewer became physically involved, although not collaborating with the student to solve the measurement problem. It was merely necessary for someone to hold the bottle while the water flowed out, therefore the mediation remained at the level of signs.

At the first level of analysis, moments of mediation were identified and coded, as for interviews 1 and 2. The resulting summary was examined through constant comparison for emergent patterns. In addition, students' predictions in subtasks 2, 3 and 4 were categorised as to whether they were accurate, acceptable or incorrect.

Transcriptions of the interviews were compiled, with close attention to students' gestures and actions as well as their utterances. These were transcribed by the researcher, with care taken to return to the original video recordings several times to verify that gestures and actions had been accurately captured. These were regarded as crucial to the data, as the particular terminology was new to the students, and while all of the students had prior experience in being taught in English, none of them had English as their home language.

7.3 DATA PRESENTATION AND ANALYSIS: SUBTASKS 1 AND 2

Data from Subtasks 1 and 2 are presented together as they were similar in form. Both required the calculation of average flow rate for the given time period of 10 seconds. This section is divided into four main parts: a general summary of performance for both subtasks; an analysis of data from Subtask 1; an analysis of the predictions offered for Subtask 2; and an analysis of data from Subtask 2.

During each subtask, students were asked two questions, and these will structure the description of the students' engagement in these subtasks. The questions were:

- (1) What is the volume of water that flowed out in 10 seconds?
- (2) What is the average flow rate?

7.3.1 General summary of performance: Subtasks 1 and 2

Table 7.1 summarises the moments of mediation per student, subtask and question. The level of mediation is indicated, and they are listed in the order in which they were provided during the interview. The full transcripts for these two subtasks are included as Appendices V and W.

The codes used to describe the moments of mediation (as explained in section 4.5.2.4) are listed, in order from the lowest to the highest level of mediation, below:

- A: no mediation
- B: reassurance
- C(m): prompt (method)
- C(c): prompt (concept)
- D(m): leading question (method)
- D(c): leading question (concept)
- R(a): referral to artefact to show physical interpretation of answer
- E(m): instruction (method)
- E(c): instruction (concept)
- F(m): correction (method)
- F(c): correction (concept)

A new category emerged from an analysis of this interview, that of R(a). This category accounted for moments in which reference was made by the interviewer to an artefact in order to demonstrate the physical interpretation of an answer provided by the student. For example, if a student erroneously predicted that four units would flow out in one second, the interviewer would spread their finger and thumb four units apart and place them on the cylinder. Explicit

explanation was not provided as it was left to the student to interpret what this meant in the context of their understanding of the situation. Such reference to the artefact did not fit into the category of explicit instruction [E] as it was not accompanied by an explanation as to why the student's original response was inaccurate. It was therefore classified as implicit, although less implicit than a leading question [D], as it physically directed the students' attention to a attribute of the artefact rather than providing an implicit lead through language.

Students' predictions for Subtask 2 are included in the table. They are classified as accurate, acceptable, or incorrect and will be explored further in Section 7.3.3.

Table 7.1 General summary of performance: Task 3, Subtasks 1 and 2

	Subtask 1 Question 1	Subtask 1 Question 2	PREDICTION Subtask 2	Subtask 2 Question 1	Subtask 2 Question 2
Ntando	F(c); F(c)	E(c)	Acceptable	C(c)	A
Mzwakhe	D(c)	C(m)	Accurate	A	A
Neliswa	A	A	Accurate	A	A
Nobuhle	F(c)	A	Incorrect [R(a) provided]	A	A
Aviwe	A	D(m); R(a)	Acceptable	A	A
Sisipho	F(c)	A	Accurate	A	A
Malusi	A	R(a)	Accurate	A	A
Phumzile	D(c)	D(c); F(c)	Accurate	A	A
Sandla	D(c)	A	Acceptable	C(m)	A
Andiswa	A	E(c)	Acceptable	A	A
Mkhuseli	A	D(m); C(m)	Accurate	A	A
Babalwa	F(c)	A	Accurate	C(c)	E(m)
Andile	A	R(a)	Acceptable	C(m)	A
Sanele	A	R(a); E(c)	Incorrect [R(a) provided]	A	A
Thandiwe	A	E(c)	Accurate	A	C(c)
Linda	D(c); F(c)	R(a)	Acceptable	A	A
Malume	A	R(a)	Acceptable	A	A
Lwazi	F(c)	B	Acceptable	A	A

7.3.2 Performance in Subtask 1

Figure 7.1 provides a summary of the mediation provided to students for questions 1 and 2 of Subtask 1. Column A provides the number of students who required no mediation for the task,

and not the number of moments of mediation as does the rest of the graph. It is included for the value it holds in the comparison of performance between questions 1 and 2.

Figure 7.1 Mediation provided during Subtask 1

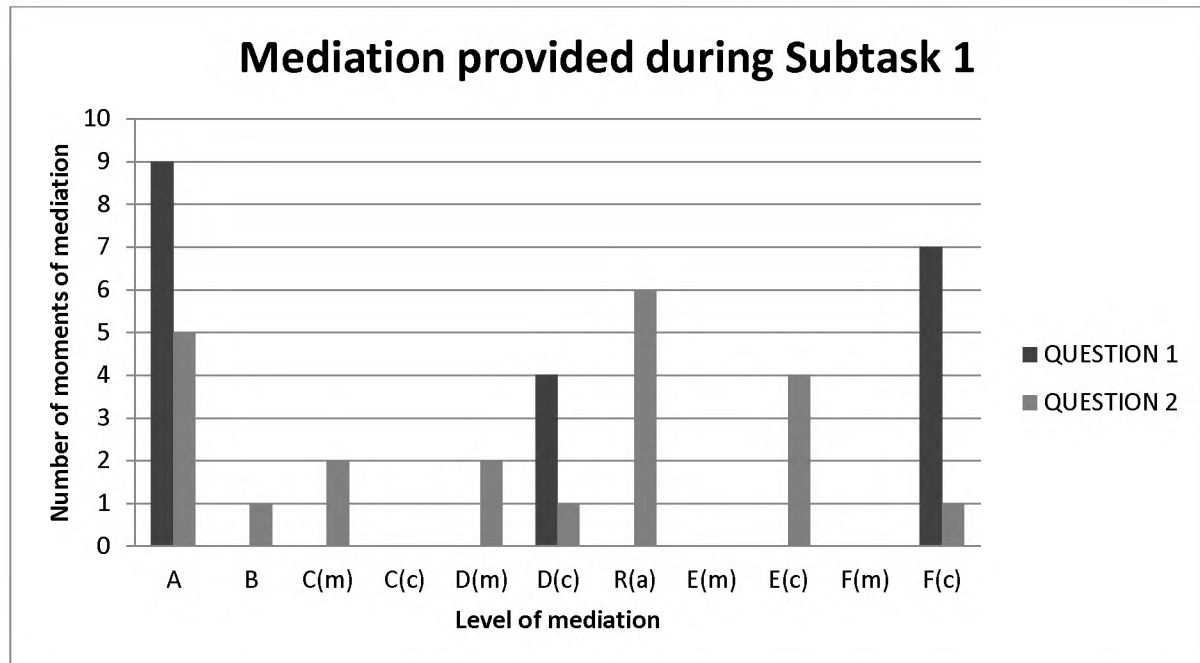

In question 1, students were asked to measure the volume of liquid that flowed out of a bottle in ten seconds. Nine of the eighteen students were able to do this accurately without any mediation. For the remaining nine, only two types of mediation were required: conceptual-level correction [F(c)] and conceptual-level leading questions [D(c)].

There were 7 moments in which conceptual correction [F(c)] was required. Six of these moments were in response to the conceptual error of interpreting each of the hash marks that showed the calibration of the bottle as being one unit of volume. Only two of the six students requiring this mediation (Ntando and Babalwa) and both needed mediation for the same reason in Subtask 2 (see Table 7.1).

Ntando required an extra moment of conceptual-level correction [F(c)]. This was in relation to his use of fraction notation. The interaction follows below:

Interviewer: What is the volume that flowed out in 10 seconds?
 Ntando: You said we had six? So we can say it's 1, 2, 3 [counting hash marks], and maybe let's say 4 quarters or 3 quarters

- Interviewer: [F(c) – correction of error in measuring volume by counting hash marks]
- Ntando: two and...oh...3 quarters...
- Interviewer: F(c) [help to write correctly, was writing $1/3$ instead of $3/4$]

There were four moments in which a conceptually-focused leading question [D(c)] was required. In each of these instances a student had provided as a solution the volume remaining in the bottle, rather than the volume that had flowed out. As they were interpreting the linear scale correctly with regard to how it related to units of volume, a leading question was offered rather than correction. The question, ‘are we measuring the volume that flowed out or the volume that remained in the bottle?’, was all that was required for these students to correct their answer.

Question 2 required students to calculate the flow rate in units per second by dividing the volume measured in question 1 by 10 seconds. More students required mediation for this question, and a wider variety of levels of mediation were provided.

The level of mediation referred to by the emergent code ‘R(a)’, was provided 6 times to students as they calculated the flow rate. In each case it was either in response to a student who had applied the calculation $time \div volume$, rather than its inverse, or had applied the calculation $time \times volume$. For example, Andile stated, ‘I’m thinking times...2.5... times 10’, and Malusi keyed $10 \div 3$ into his calculator to arrive at his initial answer of 3.3units/second. These students were shown, with reference to the bottle, what their answer would mean if the flow rate they calculated was to occur for 10 seconds [R(a)]. This was only shown, neither the calculation nor the operation were spoken of, the students linked it to the process of calculation for themselves. Only one student required mediation subsequent to the provision of ‘R(a)’.

Other than Ntando, whose interaction with the interviewer is given above, two other students, Mkhusele and Lwazi, chose to use fractions as representations of rational numbers rather than decimals. Several mentioned the word ‘half’ in their answers to question 1, but used decimal notation as soon as they moved on to question 2. Andile is one such student who responded to question 1 with ‘two and a half’, but referred to this as ‘two point five’ during question 2.

Mkhusele referred to rational numbers in an attempt to answer question 2, and was accurate in the first part of his solution. He was unable, however, to complete the calculation accurately

and it was suggested that he use a calculator. He was immediately able to complete the calculation:

Interviewer: What is the flow rate?
Mkhuseli: for five it's going to be...one and a quarter
Interviewer: [D(m)]...and for one second?
Mkhuseli: [calculating mentally] ...an eighth...half of a quarter
Interviewer: [C(m) – point to the calculator]
Mkhuseli: [presses $2.5 \div 10$] 0.25units/sec

Lwazi was able to complete his calculation verbally, in terms of rational numbers, without using decimals:

Interviewer: What is the flow rate?
Lwazi: [calculates mentally] half in 2 seconds...
Interviewer: [B]
Lwazi: [calculates mentally] a quarter units per second

Lwazi was, however, unsure of how to record this in writing. It was evident in this interaction that he was able to work very well conceptually, but in his inability to record this showed that he was uncomfortable with the symbolic representations of these concepts. It is possible that this lack of comfort forced him to engage at a more conceptual level.

Similarly, Ntando also required mediation in order to convert his answer in question 1 ($2\frac{3}{4}$) to a decimal:

Interviewer: What is the flow rate?
Ntando: I'll have...let's say...um...it's less...is it 2.4 or 2.3?
Interviewer: [E(c) – explained how to convert $\frac{3}{4}$ to a decimal]
Ntando: [presses $2.75 \div 10$] 0.275units/sec

The students who used rational numbers referred only to halves, quarters or eighths. Some of those who chose to use decimals worked with a higher degree of precision because of their choice of decimals as a representational tool. Andiswa, for example, measured 2.8 units as the solution to question 1, and Malume used 1.8 units. In both of these examples, this decimal value was more accurate than $2\frac{3}{4}$ or 3 in the case of Andiswa, and was more accurate than $1\frac{3}{4}$ or 2 in the case of Malume.

7.3.3 Predictions for Subtask 2

Students were asked to predict the volume that would flow out for a period of ten seconds from a hole with half of the diameter of that in subtask 1. They were also told that the hole was at the same level as that in Subtask 1. Their predictions were categorised as either ‘accurate’, ‘acceptable’ or ‘incorrect’.

The figure below provides a breakdown of how many student responses fitted these categories:

Figure 7.2 Student predictions for subtask 2

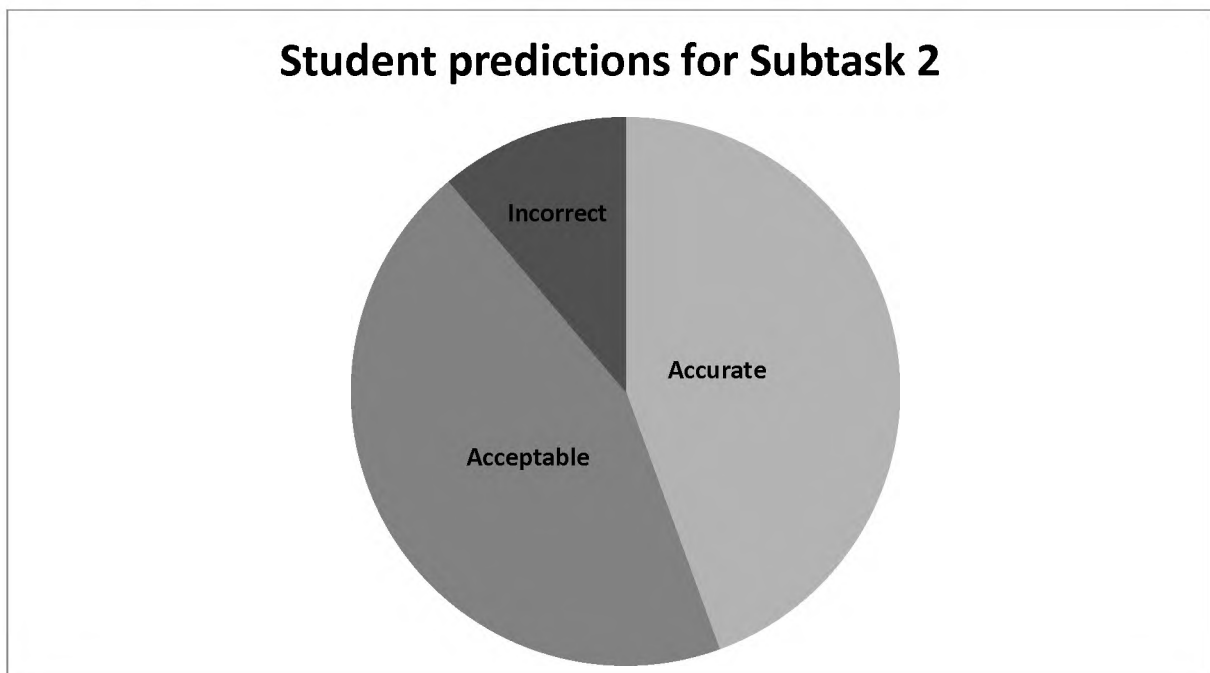

The accurate solution was 1 unit, and responses of 1 unit or 1.25 units were considered accurate. Answers were categorised as ‘acceptable’ if they indicated an amount less than that for Subtask 1. These included the responses of Andiswa, Malume and Andile who did not give a numerical value but did indicate that it would be ‘less’, providing an indication of ‘quality’ rather than an expression of ‘quantity’. This is possibly an indication that these students were not, as yet, able to quantify.

Ntando’s prediction of 2 units was deemed acceptable, particularly as he provided sound conceptual reasoning for his response:

Interviewer: What do you think the volume would be that flows out in ten seconds if the size of the hole is halved?

Ntando: ...um...the hole is a little bit smaller...I think it would be...um...I think it would be 2 [units]

Sisipho and Phumzile provided predictions that were considered accurate, and also gave their reasoning:

Interviewer: What do you think the volume would be that flows out in ten seconds if the size of the hole is halved?

Sisipho: 1 'cos it's a smaller hole and there isn't very much that is going to come out

Interviewer: What do you think the volume would be that flows out in ten seconds if the size of the hole is halved?

Phumzile: [entered $2.5 \div 2 =$ on his calculator] I think 1.25 because this hole is half of that one [points to the hole that was open for subtask 1]

Only 2 students were incorrect. Sanele said '5 units' and Nobuhle stated 'I think it will be 4 or 5'. Students were asked to look at the bottle and show the interviewer how much 4 units of volume would be (mediation at level 'R'). They were immediately able to realise that their estimate should have been less than the volume obtained in Subtask 4. These students also went on to correctly complete Subtask 2 without mediation.

7.3.4 Performance in Subtask 2

Student performance in Subtask 2 was interpreted with reference to their performance in subtask 1. Subtask 1 served as an opportunity to view students' engagement with a flow rate task prior to gaining experience with the task. Subtask 2 provided an opportunity to view their performance subsequent to gaining this experience and, for all except Neliswa, subsequent to receiving mediation in order to complete Subtask 1.

Figure 7.3 provides a summary of the mediation provided to students for Subtasks 1 and 2. Unlike Figure 7.1, which provided a comparison between each question in Subtask 1, this figure provides a comparison between subtasks that is inclusive of both questions. In other words, column A provides the number of students who were able to complete either question 1 or question 2 without mediation.

As with Figure 7.1, column A does not reflect the number of moments of mediation, but rather the number of students requiring no mediation. It is included in this way for the purposes of the discussion which follows after the figure.

Figure 7.3 Mediation provided during Subtasks 1 and 2

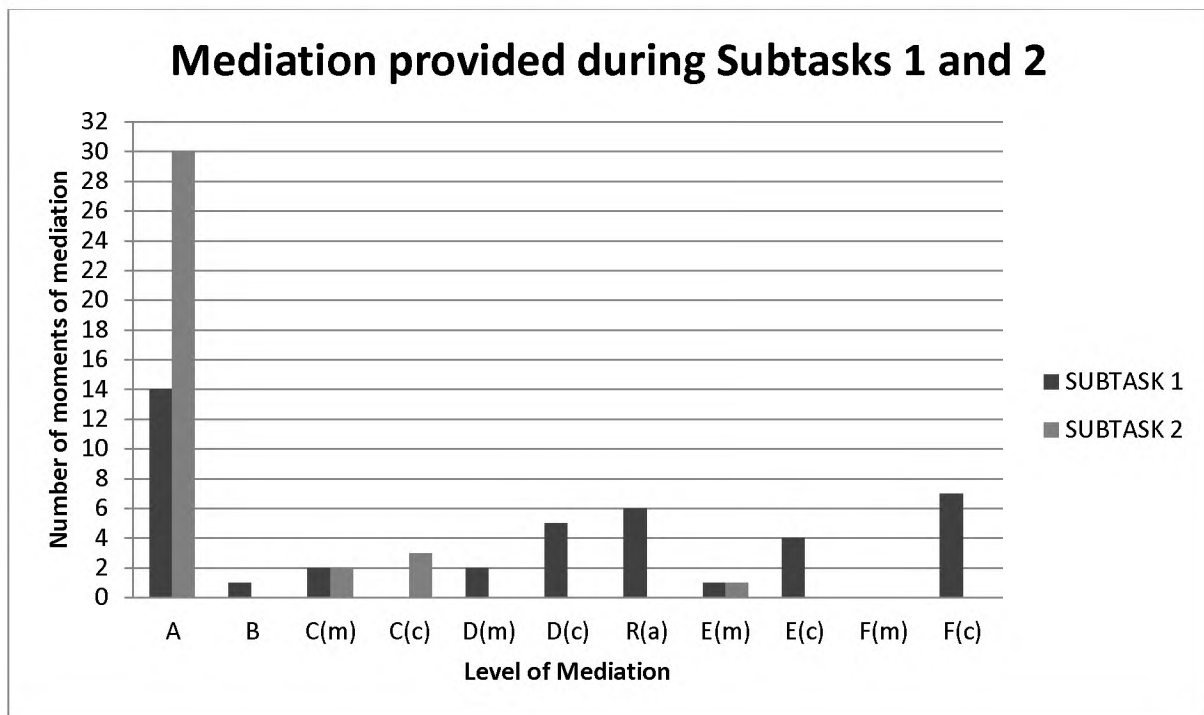

The number of students requiring no mediation in Subtask 1 more than doubled for Subtask 2. In addition, the total number of moments of mediation provided in Subtask 2 was only 6 as opposed to the 28 required in Subtask 1. With the exception of only one moment of method-level instruction, all moments in Subtask 2 were at an implicit level.

Only one student, Babalwa, required mediation for both question 1 and 2. The first was a conceptual-level prompt [C(c)] provided as a reminder not to count the hash marks in his measurement of volume units for question 1. He had done the same in subtask 1, for which he received conceptual-level correction. In this case, a prompt was sufficient for him to realise the error and correct it.

The mediation Babalwa required for question 2 was method-level instruction [E(m)]. He mentally calculated 0.5units/sec as the flow rate for subtask 2 and explained that he had ‘tried to divide’. Interestingly, he had obtained the correct answer in subtask 1, question 2, without the need for any mediation.

Thandiwe was the only other student to require mediation for question 2. She had required conceptual-level instruction [E(c)] for question 2 of Subtask 1, and while she needed mediation for the same question in subtask 2, it did decrease in level to implicit mediation.

The remaining 3 moments of mediation for Subtask 2 were all prompts for question 1 that were provided to students who counted hash marks rather than volume units. These three students had either done this correctly in subtask 1 with no mediation (Andile) or had already received mediation in this regard (Ntando and Sandla) and thus only required a prompt for Subtask 2.

7.3.5 Summary

This section has provided details of the engagement of the students in the first half of this interview. It is notable that from Subtask 1, in which students encounter the concept for the first time, and Subtask 2, in which students work on a related flow rate problem, that there is such a dramatic decrease in mediation required. It is reasonable to assume that there would be a decrease, as Subtask 1 allows them an opportunity to engage with the concept, but the extent of this decrease suggests that real learning occurred as they engaged in the task.

7.4 DATA PRESENTATION AND ANALYSIS: SUBTASKS 3 AND 4

In Subtasks 1 and 2, students were required to measure the volume which flowed out of a bottle in a given time period. In Subtask 3, their attention was turned to the time it would take for a given volume to flow out. In each subtask, two questions were asked:

- (1) How long did it take for 4 units to flow out of the cylinder?
- (2) What is the average flow rate?

As for Subtasks 1 and 2, data from Subtasks 3 and 4 are presented together as both were similar in form. First, the data from Subtask 3 will be presented and analysed, focusing on the predictions students offered as well their performance with reference to questions 1 and 2. Thereafter, the same presentation and analysis will be made for Subtask 4.

Mediation did not occur during these two subtasks in the same way as it did in Subtasks 1 and 2. Students made predictions and gave descriptions of the events in both of these subtasks, and their conceptual grasp was inferred from these. As the experiment itself was longer for Subtasks 3 and 4 than Subtasks 1 and 2, there was more for the students to observe. The flow rate very obviously decreased during the time it took for the 4 units of water to flow out, and this formed part of what the students were required to explain.

The analysis here is focused predominantly on the students' verbal explanations as they responded to the questions posed to them during these subtasks. It also focused on how students

responded to either confirmation or rejection of their predictions after observing the experiment.

There were moments in which it was evident that a student held a misconception regarding the attribute of flow rate. In the majority of such cases the misconception was resolved after observing the experiment and it was not the desire of the interviewer to interfere in this process. These moments were noted, but not addressed until the conclusion of the interview when the full task was reviewed with the student.

The full transcripts for these two subtasks are included as Appendices X and Y.

7.4.1 General summary of performance: Subtask 3

In Subtask 3, the holes from which the water was to flow were positioned as shown in the figure below. Both holes were identical in diameter to the single hole in Subtask 2. The students observed as 4 units flowed out these holes and timed this process.

Figure 7.4 Position of holes for Subtask 3

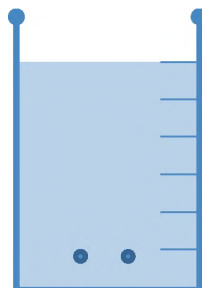

7.4.1.1 Student predictions for Subtask 3

Student predictions were categorised in the same manner as for Subtask 2: ‘accurate’, ‘acceptable’, and ‘incorrect’. An additional category, ‘unable’, was included as there were 4 students who would not provide a prediction, despite encouragement to do so.

In the ten seconds allowed for Subtask 2, one unit of water flowed out. Were a student to apply proportional reasoning, they would predict that if two holes were opened it would take 20 seconds for 4 units to flow out. This answer would, however, not account for the effect of the decrease in pressure as the level of the water dropped. This caused the flow rate to decrease with time, and the time measured was therefore approximately 30 seconds.

For this subtask, predictions that were considered ‘acceptable’ were those that indicated a time period longer than that for Subtask 2. Students needed to recognise that although two holes, identical to the single hole in Subtask 2, were opened, the time it would take for the 4 units of water to flow out would be longer than ten seconds.

The table below provides a summary of students’ responses to the interviewer’s request for a prediction. The categorisation of these predictions is included.

Table 7.2 Summary of predictions: Subtask 3

	Category: Prediction Subtask 3	Prediction, Subtask 3
Ntando	Unable	
Mzwakhe	Acceptable	‘40 seconds for 4 units’
Neliswa	Unable	
Nobuhle	Incorrect	‘more flow rate’
Aviwe	Incorrect	‘5 seconds’
Sisipho	Incorrect	‘about same as first [subtask 1; 10 seconds]’
Malusi	Acceptable	‘I think it will be 20 seconds’
Phumzile	Incorrect	‘4 seconds’
Sandla	Acceptable	‘15 seconds’
Andiswa	Unable	
Mkhuseli	Incorrect	‘2 and a half [units]...it’s going to be the same as...[points at answer to subtask 1]...two holes...the same as one big one...[long pause]...I think it’s going to be the same as...[points at answer to subtask 1]...10 seconds’
Babalwa	Incorrect	‘5 seconds’
Andile	Acceptable	‘75 seconds’
Sanele	Incorrect	‘5 seconds’
Thandiwe	Incorrect	‘5 seconds or less than 5’
Linda	Incorrect	Linda: 20...there’s 2 holes? Interviewer: Yes Linda: ...then 8
Malume	Incorrect	‘2.6 seconds’
Lwazi	Unable	

There were 4 students who were unable to provide a prediction. Of the remaining 14 students who attempted to provide one, only 4 students were able to provide an acceptable prediction, while 10 provided incorrect predictions that revealed misconceptions.

In terms of proportional reasoning, Malusi provided a perfect response. His prediction of 20 seconds was, however, categorised as ‘acceptable’, as it had not shown awareness of the decreasing flow rate over time. The other students whose responses were categorised as ‘acceptable’ were Mzwakhe, Sandla and Andile, who predicted 40 seconds, 15 seconds and 75 seconds respectively. No students provided an accurate prediction.

Incorrect predictions were those that indicated a time period of less than ten seconds. Four students chose 5 seconds as their prediction. These students halved the time allowed in subtask 2 due to the presence of 2 holes identical to the single hole used in that subtask. This showed correct proportional reasoning if a single unit was to flow out, as in Subtask 2 and meant that their error was not conceptual in nature. Instead they had not taken into account the fact that four times this amount was to flow out in this subtask.

Sisipho reasoned that it would be ‘about the same as the first [subtask]’. In other words, it would take 10 seconds for the 4 units to flow out. The first subtask involved a hole with double the diameter of the hole in Subtask 2, which therefore equalled the summed diameters of the holes in subtask 3. Again, assuming that she saw the question as asking how much time it would take for a single unit to flow out, the reasoning is proportionally sound. Mkhuseli provides the same prediction, but verbalised his reasoning in more detail:

2 and a half [units]...it’s going to be the same as...[points at answer to subtask 1]...two holes...the same as one big one...[long pause]...I think it’s going to be the same as...[points at answer to subtask 1]...10 seconds

He demonstrated an awareness that the number of units is significant when he states, ‘2 and a half’, as this was his volume measurement in Subtask 1. He then turns his attention to the diameters of the holes and after recognising that the large hole’s diameter is the sum of that of the two small holes, ignores the volume variable to conclude that the number of seconds measured in Subtask 3 would be 10 seconds.

Nobuhle was the only student not to predict a time, but rather stated, ‘more flow rate’. While this increase in flow rate from that in Subtask 2 would be the case if only ten seconds were allowed, the average flow rate for Subtask 3 was in fact lower due to the decrease in flow rate over time. Her response was therefore considered ‘incorrect’.

The remaining students provided predictions lower than 10 seconds without providing verbal explanations.

7.4.1.2 Subtask 3, Question 1

Question 1 required students to use the stopwatch provided to measure the amount of time it took for 4 units of water to flow out via the two horizontal holes. There were no students for whom this was problematic. It was their responses to probing questions subsequently posed by the interviewer that indicated their conceptual understanding of what had happened during that time. These probing questions included:

- What did you notice?
- Why do you think that happened?
- Why is this measurement different to your prediction?

Neliswa, who was unable to provide a prediction for this subtask, remained unsure of what to say, and again declined to provide a reason or description of what had happened, despite being encouraged to do so. She was, however, able to complete the calculations in this subtask accurately and independently.

The remaining students mentioned a variety of factors in their responses to these questions. There were a number of key words that were used by students to refer to various factors. The use of the word ‘it’ was also analysed. At times ‘it’ was used with reference to volume, and at other times ‘it’ was used to refer to the flow rate. The number of such utterances is therefore included in Table 7.3.

The number of utterances counted for the word ‘hole’ includes moments in which students pointed to the holes in their explanations as a substitute for using the word. For example, Malusi explains, ‘I think the pressure is not too much when you have two of them [points to holes]’. In the same way, one student pushed his hands together as a gesture to demonstrate this effect the effect of pressure, and this has been included in the count of utterances/gestures of ‘pressure’

Table 7.3 lists these words in order of frequency.

Table 7.3 Summary of use of keywords: Subtask 3

	Number of utterances/gestures	Number of students	Example
Hole	11	8	Nobuhle: ... the hole is still small
Pressure	11	7	Andile: It had a lot of pressure and then is starting to stop
Slow/slower	10	8	Mkhuseli: Water was coming out slower
It (volume)	10	10	Sandla: it's coming out
It (flow rate)	8	6	Sandla: then it drops
Fast/faster	6	6	Sisipho: It was fast and then went slow
Stream	5	5	Sanele: ... streams are same, then less
Water	4	4	Sisipho: ... it's the water ... it's out
Volume	4	3	Nobuhle: Because of the volume , the volume became less
Flow rate	4	2	Interviewer: What did you notice? Lwazi: They are the same... they come out fast and then slow, slow... at the top [of the bottle]... large flow rate , in middle – medium flow rate , lower – small flow rate
Force	2	2	Interviewer: What did you notice? Babalwa: Both of them went slower Interviewer: Why do you think that happened? Babalwa: Force!
Stronger	1	1	Linda: The stream started out stronger
Quickly	1	1	Phumzile: It was coming out very quickly
Pushing	1	1	Andile: I think it's because the thing was full and pushing
Here (holes)	1	1	Thandiwe: when it comes here
Full	1	1	Andile: It's because the thing was full
Units	1	1	Linda: ... there were 4 units

In this subtask the accurate terminology for the variables involved would be *pressure*, *volume*, *flow rate* and the influence of the *diameter* and/or *positioning of the holes*. The examples given in Table 7.3 showed some conceptual insight although the vocabulary used was at times misleading.

Speed is a rate, just as flow rate is, however the relationship between distance travelled and units of time (speed) and the relationship between the flow of a volume of liquid per unit of time (flow rate) are not the same concepts. However, it was noticed that where students were using speed-related terminology (e.g. fast, slow, or quick), substituting these with descriptions of flow rate, without changing the structure of their argument would correct the apparent conceptual error. As an example, Linda's use of the word 'stronger', in her phrasing of the description, also constituted a reference to rate, as well as certain examples where the word 'it' was used.

For example:

Sisipho: **it** was **fast** and then went **slow**
 Adjusted statement: The **flow rate** was **high** and then **decreased**

Phumzile: it was coming out very **quickly**
 Adjusted statement: the flow rate was high

Linda: the stream started out **stronger**
 Adjusted statement: the **flow rate** was higher at the beginning

Nobuhle: **it** was the same
 Adjusted statement: the **flow rate** from each hole was the same

In the case of references to volume, the same could be done with the terms 'water', 'stream' and 'units', as well as certain examples where the word 'it' was used. These words were used by the students to indicate the amount of liquid flowing out:

Mzwakhe: the **streams** of **water** changed
 Adjusted statement: the **volume** flowing out changed

Ntando: the **water** was getting less
 Adjusted statement: the **volume** was decreasing

Linda: the holes were small...there were 4 **units**
 Adjusted statement: the holes were small...the **volume** that flowed out was 4 units

Ntando: when **it** was going down the pressure dropped
 Adjusted statement: as the **volume** decreased, the pressure dropped

Where students made use of the terms ‘force’, ‘stronger’ and ‘pushing’, these could similarly be substituted with the more accurate term ‘pressure’. For example

Andile: I think it’s because the thing was full and **pushing**
Adjusted statement: I think it’s because the thing was full and the **volume** of water was **exerting pressure** on the liquid

In addition, when students mentioned ‘holes’ or pointed to the holes on the bottles as described their observations, they were either making reference to the size or positioning of the holes. Thandiwe also made use of the word ‘here’ to indicate the positioning of the holes:

Thandiwe: when it comes **here**...
Adjusted statement: when the level of the water reaches the **top hole**

Following these observations, the key words could be grouped together according to what they collectively referred to. The words ‘pressure’, ‘force’ and ‘pushing’, as well as the one student’s gesture that indicated pressure, can all be considered to refer to the influence of *pressure* on the flow rate. The words ‘volume’, ‘water’, ‘stream’ and the statement ‘the thing was full’ can be taken to refer to *volume*. The words ‘flow rate’, ‘fast/faster’, ‘slow/slower’, and ‘quickly’ all refer to a *rate*, in addition, Linda’ statement that ‘the stream started out stronger’ was a reference to the *flow rate*. Lastly, use of the word ‘hole’ and pointing to the holes could be considered recognition of the *influence of the diameter* and/or *positioning of the holes* on the flow rate.

Figure 7.5 shows the number of utterances of these words, phrases or the use of gestures grouped into the categories of variables to which they refer.

Figure 7.5 Subtask 3: Number of utterances/gestures referring to each variable

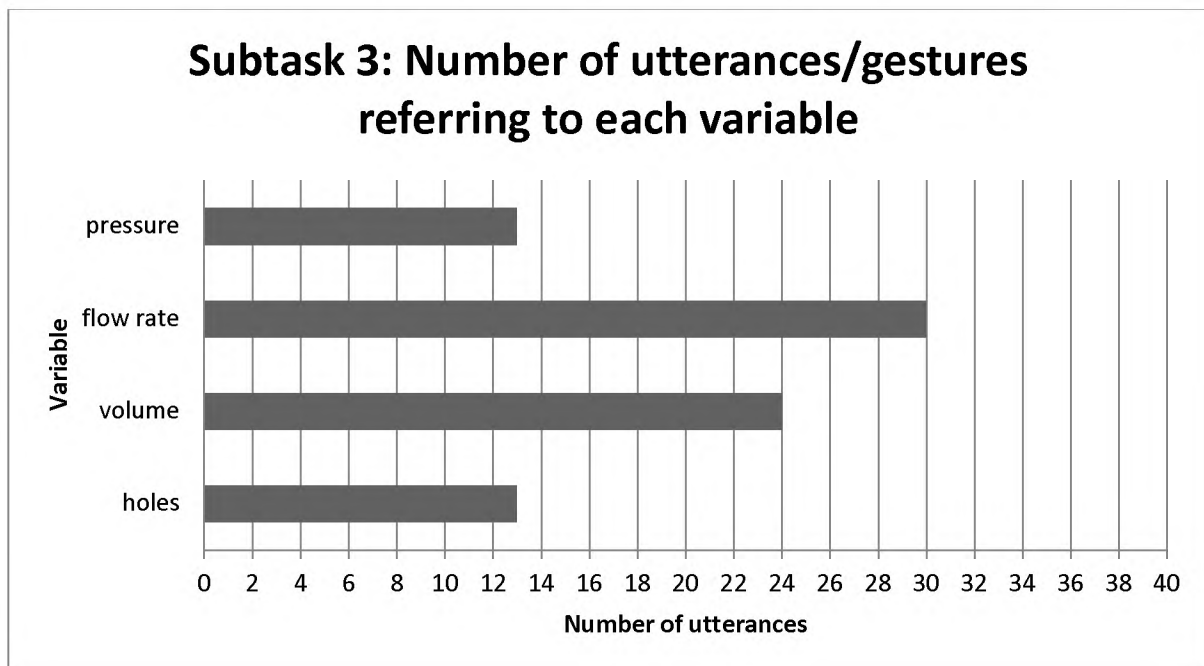

References to flow rate and volume occur the most, although with a relative lack of precision in the terminology. With volume being the distinguishing variable for flow rate when compared to other rates with which the students seemed more familiar (e.g. speed), this provides some evidence that they are aware of the differing nature of this measurement, although not necessarily yet having the precise language with which to describe it.

7.4.1.3 Subtask 3, Question 2

Question 2 asked the students what the average flow rate was for this subtask. The units of volume that flowed out were to be divided by the time in seconds that it took to do so. This is the same calculation that was required in Subtasks 1 and 2. In this case, however, every student arrived at the accurate solution without explicit mediation.

Figure 7.6 shows the mediation provided for this calculation from Subtask 1 to Subtask 3. As with Figures 7.1 and 7.3, column A reflects the number of students for whom no mediation was required, rather than the number of moments of mediation.

Figure 7.6 Subtasks 1 – 3, Question 2: Mediation provided

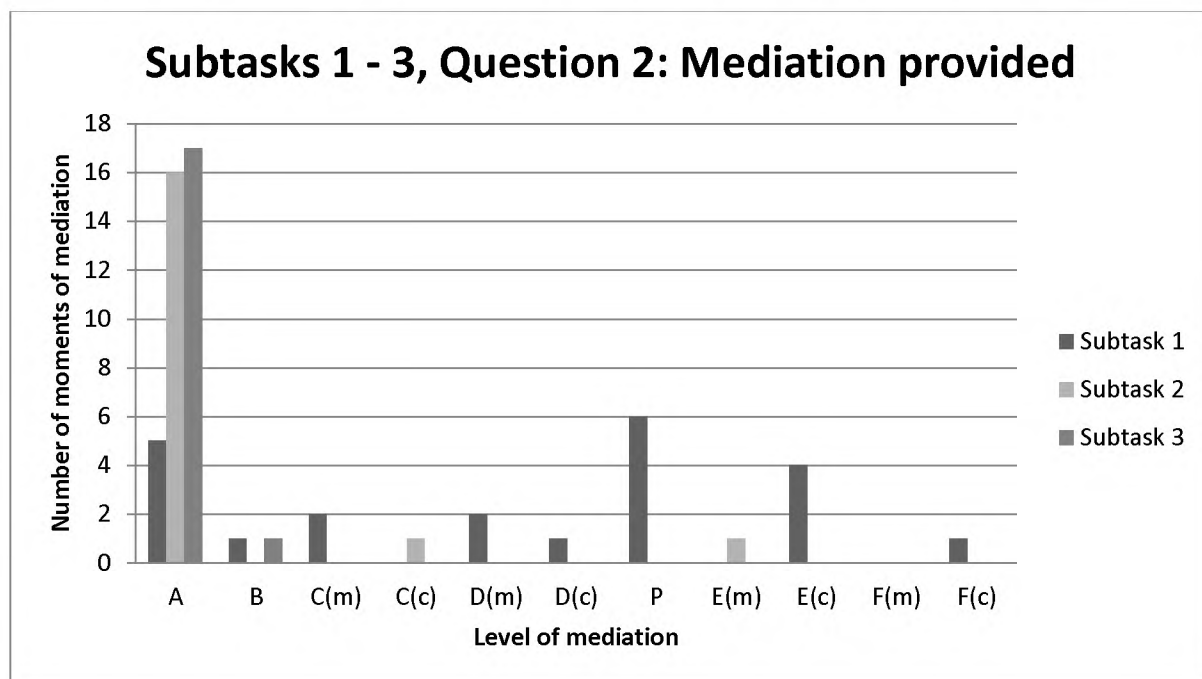

Only one moment of mediation was provided in subtask 3. Ntando looked to the interviewer for reassurance [B], which was provided as a head nod, and he proceeded to do the calculation independently and accurately. Two students started the calculation incorrectly, attempting to do the inverse calculation ($time \div volume$), but self-corrected their error.

There is clear evidence that the students made progress from Subtask 1, in which only 5 students were able to complete the calculation without mediation, to Subtask 3, in which only 1 student required reassurance [B].

7.4.2 General summary of performance: Subtask 4

In Subtask 4, the holes from which the water was to flow were positioned as shown in the figure below. Both holes were identical in diameter to the single hole used in Subtask 2, and both of the holes used in Subtask 3. In contrast to subtask 3, however, the holes were positioned vertically relative to one another, rather than horizontally. As with Subtask 3, students observed as 4 units flowed out of these holes and timed this process.

Figure 7.7 Position of holes for Subtask 4

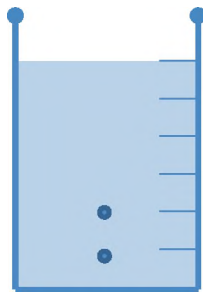

7.4.2.1 Student predictions for Subtask 4

Student predictions were categorised in the same manner as for Subtask 3, however, only two categories applied: ‘acceptable’, and ‘incorrect’. There were no students who were unable to provide a prediction, and there was no student who provided an accurate prediction.

During Subtask 3, students saw a clear decrease in the flow rate with time. As the level of the water dropped, so the flow rate decreased. They commented on this in various ways, including mention of ‘pressure’ in their explanations, descriptions of a change in the ‘streams of water’, or commenting that it ‘slowed down’.

The more obvious contribution of the variable of pressure meant that fewer student predictions relied on proportional reasoning. Despite being asked to predict the amount of time that it would take for 4 units to flow out, many students chose to provide a detailed description of what they expected to see rather than provide a numerical response. These descriptions were made in comparative terms, with reference to Subtask 3.

For this subtask, predictions that were considered ‘acceptable’ were those that either indicated a time period longer than that for Subtask 3, or correctly described what would occur during the experiment. Students needed to recognise that although two holes, identical to those used in Subtask 3, were opened, the time it would take for the 4 units of water to flow out would be longer than that measured in that subtask. The vertical arrangement of the holes would mean that once 3 units had flowed out, only one hole would remain operational, and therefore the required time would be increased.

The table below provides a summary of students’ responses to the interviewer’s request for a prediction. The categorisation of these predictions is included.

Table 7.4 Summary of predictions: Subtasks 3 and 4

	Category: Prediction Subtask 3	Category: Prediction Subtask 4	Prediction, Subtask 4
Ntando	Unable	Incorrect	‘The flow rate will be less than this [indicates subtask 3], the water will be coming out of both holes...but sooner or later it will be coming out of one hole [points at bottom hole]...then it will be same pressure, in time it will be shorter’
Mzwakhe	Acceptable	Incorrect	‘20 seconds’ [less than subtask 3]
Neliswa	Unable	Acceptable	‘32 seconds’ [more than subtask 3]
Nobuhle	Incorrect	Acceptable	‘slower [points at answer for subtask 3]’
Aviwe	Incorrect	Acceptable	‘40 seconds’ [more than subtask 3]
Sisipho	Incorrect	Acceptable	‘I’m not sure...I’m not sure about the directions...this one [points at bottom hole] is going to slow down and this one [points at top hole] is going to stop’
Malusi	Acceptable	Incorrect	‘22 seconds’ [less than subtask 3]
Phumzile	Incorrect	Incorrect	‘20 seconds’ [less than subtask 3]
Sandla	Acceptable	Incorrect	‘shorter [than subtask 3]’
Andiswa	Unable	Acceptable	‘longer, because the two holes are too far away...because this one is at the bottom and this one is higher...and this one [points at top] will go faster than this one [bottom]’
Mkhuseli	Incorrect	Incorrect	‘20 seconds’ [less than subtask 3]
Babalwa	Incorrect	Acceptable	‘...longer...40 seconds, because when the water reaches this one [top hole] it will only have one [hole] left’
Andile	Acceptable	Acceptable	‘smaller flow rate than horizontal [holes] because this thing is full, when this [water] pushes down [gestures with one hand pushing down from top to bottom of bottle] through past this one [points at top hole] then there is one [hole]’
Sanele	Incorrect	Acceptable	‘the flow rate won’t be the same as previous one [subtask 3], the top one [hole] will go fast and then when it [water level] reaches here [points at top hole], this one [points at bottom hole] will come out and this one [points at top hole] will not come out’

Thandiwe	Incorrect	Acceptable	‘the time will be longer than horizontal [subtask 3] because this one’s on top [points to top hole]...and there’s no more [gestures to indicate water and that the flow from the top hole would stop]’
Linda	Incorrect	Acceptable	‘it is longer than [points at answer to subtask 3]...when it reaches here [top hole] this one’s going to be open and won’t go, it’s only going to be on this side [points to bottom hole]’
Malume	Incorrect	Acceptable	‘44 seconds’ [more than subtask 3]
Lwazi	Unable	Incorrect	‘20 seconds’ [less than subtask 3]

There were 11 students who provided ‘acceptable’ predictions, and 7 who were incorrect in their responses. 10 of these 11 students were either unable to give a prediction for subtask 3, or had provided an incorrect prediction. Therefore, when looking at the group as a whole, as well as more than half of the individual students, an improvement in conceptual work was evident.

Figure 7.8 shows the change, from Subtask 3 to Subtask 4, in the number of students whose predictions fall into each category. There is a clear decrease in the number of incorrect responses, and a clear increase in the number of accurate responses.

Figure 7.8 Comparison of student predictions: Subtasks 3 and 4

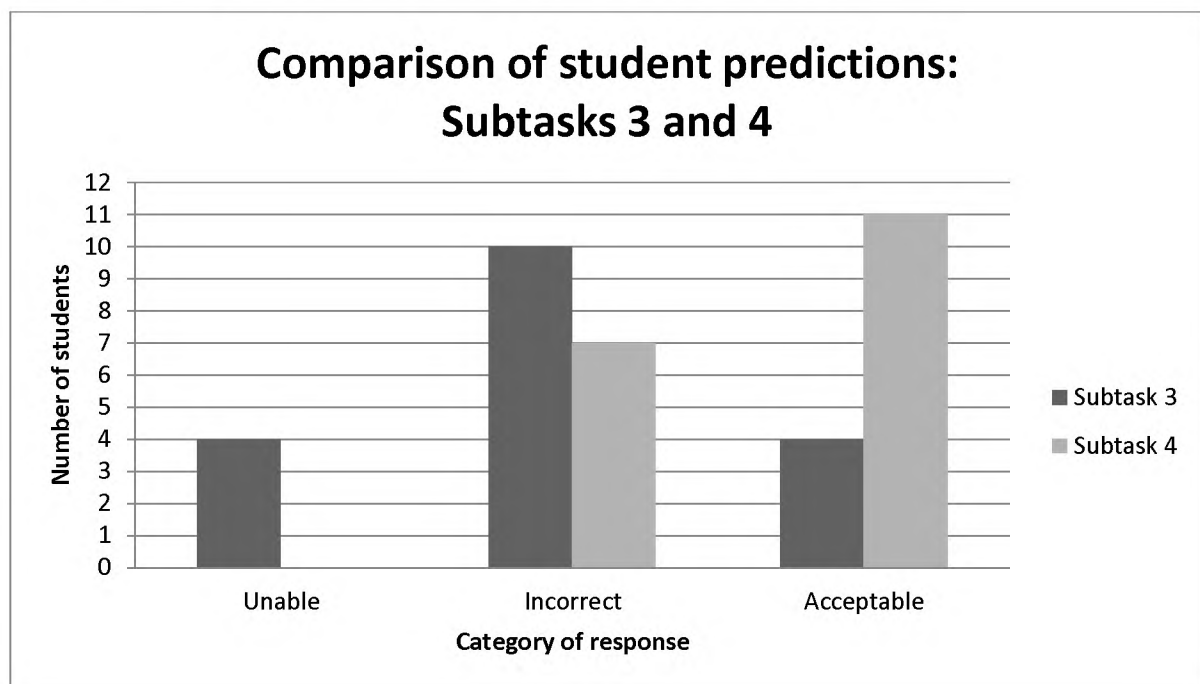

Malusi, Mzwakhe and Sandla, three of the four students who provided acceptable predictions for Subtask 3, provided incorrect predictions for Subtask 4. Each of these students predicted that in this case the time required for the four units of water to flow out would be shorter. Similarly, Phumzile, Mkhuseli, Lwazi and Ntando did not show evidence of improvement in their ability to predict the outcome of the experiment as they had either been unable to provide a prediction in Subtask 3 (Ntando and Lwazi) or had provided an incorrect prediction (Phumzile and Mkhuseli).

Lwazi, Phumzile and Mkhuseli provide simple answers that did not reveal the reasoning behind their predictions. Ntando, however, verbalised his thinking as he arrived at his prediction. He correctly states that ‘the flow rate will be less than this [points to Subtask 3]’, but as he works further it becomes clear that there are conceptual errors in his thinking. He correctly describes that the flow out of the top hole will eventually stop, but then concludes that subsequent to this, ‘it will be [the] same pressure’ and that therefore ‘in time it will be shorter’.

Four students gave simple acceptable predictions in which they simply stated a time (Malume, Neliswa and Aviwe), or in one case gave just a word to indicate that the flow rate would be ‘slower’ (Nobuhle). These did not allow insight into how they arrived at these predictions, however, the remaining students provided more descriptive predictions of what would happen and the effect this would have on the time or the flow rate.

Babalwa, Thandiwe and Linda focused only on the time, each predicting that it would take ‘longer’ for the four units to flow out than in Subtask 3. Their predictions did not refer to any change in the flow rate, but indicated that the flow would stop at the top hole after a period:

Babalwa: ...when the water reaches this one [top hole] it will only have one [hole] left

Thandiwe: ...because this one’s on top [points to top hole]...and there’s no more [gestures to indicate water and that the flow from the top hole would stop]’

Linda: ...when it reaches here [top hole] this one’s going to be open and won’t go, it’s only going to be on this side [points to bottom hole]

Andiswa makes an acceptable time prediction in his response. He states that it would take ‘longer’ for the water to flow out, but also includes mention of a change in flow rate by making a distinction that the flow from one hole would ‘go faster’ than the other. Sanele makes a similar

prediction by indicating that the flow from one hole will go ‘fast’, and that at a later stage, water ‘will not come out’ of it. Both of these students, however, make what seems to be a conceptual error in stating that the hole which would have the higher flow rate would be the top hole. It is not clear, however, whether they meant to state that it will be for a shorter period of time that water will flow out of this hole, or whether the flow rate would be higher for this hole.

Sisipho, in her prediction, shows evidence that she is aware that the flow rate will change with time when she states that, ‘...this one [bottom hole] is going to slow down and this one [top hole] is going to stop’. Andile is the student who provides the most comprehensive prediction, including an indication of how the pressure changes as the water level drops, and what the effect is on the average flow rate for the full subtask:

Andile: ...smaller flow rate than horizontal [holes] because this thing is full...when this [water] pushes down [gestures with one hand pushing down from the top to the bottom of the bottle] through past this one [points at top hole] then there is one [hole]

The predictions and reasoning of the students shows increasing sophistication and accuracy.

7.4.2.2 Subtask 4, Question 1

Students were first required to use the stopwatch provided to measure the amount of time it took for 4 units of water to flow out via the two vertical holes (Question 1). As for Subtask 3, there were no students for whom this was problematic and it was their responses to the probing questions subsequently posed by the interviewer that indicated their conceptual understanding. The same probing questions asked in Subtask 3 were used here in an attempt to elicit responses that revealed the students’ reasoning:

- What did you notice?
- Why do you think that happened?
- Why is this measurement different to your prediction?

There were a number of key words used by the students to refer to various factors. The use of the word ‘it’ was also analysed, as was done in Subtask 3. At times ‘it’ was used with reference to volume, and at other times ‘it’ was used to refer to the flow rate. The number of such utterances is therefore also included in Table 7.5.

The number of utterances counted for the word ‘hole’ includes moments in which students pointed to the holes in their explanations as a substitute for using the word. Three students pushed their hands together as a gesture to demonstrate the effect of pressure, and this was included in the count of utterances/gestures of ‘pressure’. Table 7.5 lists these words in order of frequency.

Table 7.5 Summary of use of keywords: Subtask 4

	Number of utterances/gestures	Number of students	Example
Hole	39	13	Nobuhle: ...because this one has two holes , one on top, one on bottom... then this one [points at top hole] couldn't have anything coming out, but this one [points at bottom hole] could
Pressure	21	8	Sanele: ...since it's going down the pressure is getting less
Water	14	6	Malusi: ... this one [points at bottom hole], was pumping out... pumping out the water more than that one [points at top hole]
Slow/slower	6	4	Andiswa: the top one, it was going slower
It (flow rate)	5	5	Phumzile: ... it's also decreasing
Fast/faster	4	3	Ntando: the water goes out faster
It (volume)	4	3	Lwazi: we let it out for longer
Pump	3	2	Malusi: this one [points at bottom hole] was pumping out... pumping out the water more than this one [points at top hole]
Speed	3	1	Mzwakhe: ...and the speed changed...
Flow rate	2	2	Aviwe: the pressure increases... the flow rate can be a little faster
Stronger	1	1	Malume: It stopped here [points at top hole] after a while and then it only used this one [points at bottom hole] and this one [bottom hole] was stronger

As with Subtask 3, the accurate terminology for the variables involved were *pressure*, *volume*, *flow rate* and the influence of the *diameter* and/or *positioning of the holes*. The examples given

in Table 7.5 showed some conceptual insight although the vocabulary used was at times misleading.

In Subtask 3, there were 15 words that students used to refer to these four variables. In Subtask 4, this decreased to 11, despite an increase in the average length of the descriptions provided by the students. In Subtask 3, 267 words were used by 17 students to describe what had been observed (average length of 16 words per student. In subtask 4, 381 words were used by 15 students (average length of 25 words). This suggests that students were gaining accuracy in their use of the appropriate vocabulary.

As argued in section 7.4.1.2, the key words could be grouped together according to what they collectively referred to. The words ‘flow rate’, ‘fast/faster’, ‘slow/slower’, ‘pump’, ‘speed’ and ‘stronger’, in this case, were all considered to refer to *flow rate*. The word ‘water’ was understood to be a reference to *volume*. The influence of *pressure* was described in each case with the appropriate term and the use of the word ‘hole’ as well as pointing to the holes was considered recognition of the *influence of the diameter* and/or *positioning of the holes* on the flow rate.

Figure 7.9 shows the number of utterances of these words, phrases or the use of gestures grouped into the categories of variables to which they refer.

Figure 7.9 Subtask 4: Number of utterances/gestures referring to each variable

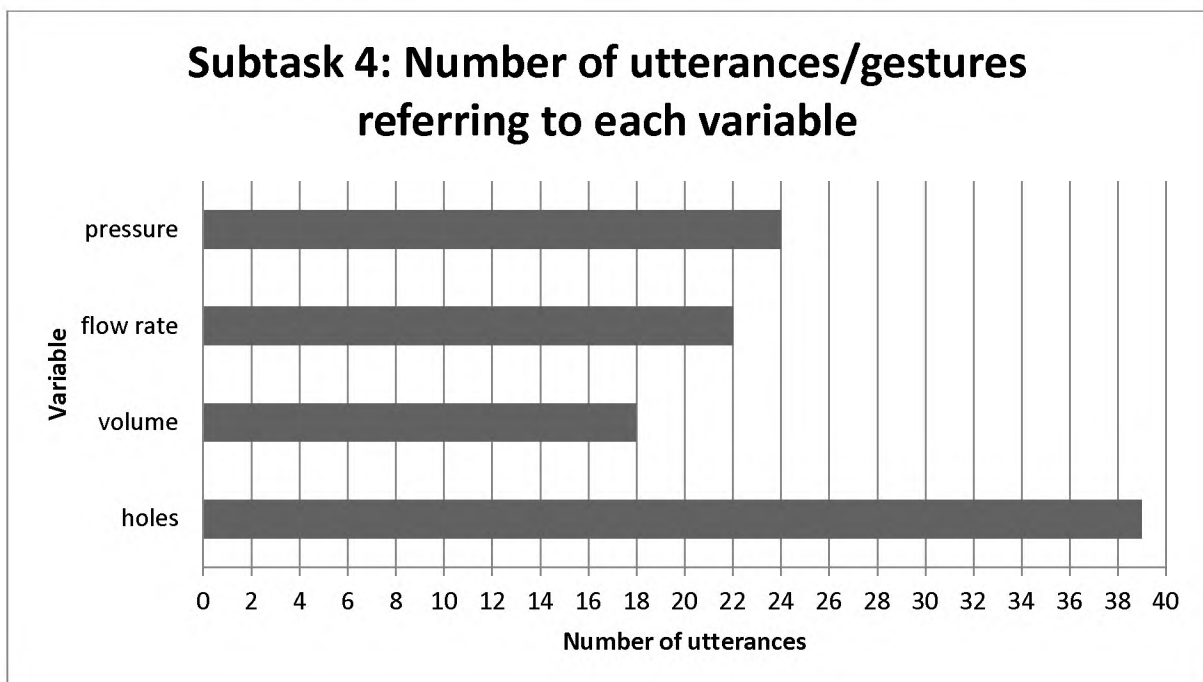

There is a change in focus in the variables to which the students refer when describing their observations for Subtask 4. This indicates that they have noted the influence of the positioning of the holes and the resulting pressure changes in the system as the water flows out. The frequency of references made to volume and flow rate are relatively small.

7.4.2.3 Subtask 4, Question 2

Question 2 required the students to calculate the average flow rate for this subtask. The units of volume that flowed out were to be divided by the time in seconds that it took to do so. This is the same calculation that was required in all of the previous subtasks.

One interview was terminated prematurely as student unrest lead to an evacuation of the campus during the interview. For the remaining 17 interviews, all of the students were able to arrive at the accurate solution without explicit mediation.

Interview 3 required students to maintain focus on a novel, complex task for approximately 45 minutes, and there were two students who showed signs of loss of concentration by this stage in the interview. Sandla and Babalwa required a method-level prompt [C(m)], in the form of the interviewer pointing at the calculation they correctly made in subtask 3, when they started dividing the time period by the number of units of volume. They then proceeded to correct their error without any further mediation, providing evidence that this was unlikely to be a conceptual error, but was rather a procedural one.

7.4.3 Summary

Student performance in Subtasks 3 and 4 show evidence of substantial development in their ability to work with the concept of flow rate. It can be argued that this is due to the effect of practice in Subtasks 1 and 2, however, the structure of the task reversed in requiring prediction of the amount of time it would take for a given volume to flow out. This reversal, and the attention paid by the researcher to the ways in which the students engaged in the tasks and substantiated their actions, provides evidence of deeper engagement than that which would be obtained by the superficial practice offered in Subtasks 1 and 2.

7.5 STABLE AND EMERGING CONCEPTUALISATIONS

Task 3 was designed to create a situation in which the students could be observed working with a new concept, previously not encountered in formal schooling, as well as a more complex,

non-spatial, measurement. By nature, Task 3 therefore would be expected to reveal emerging conceptualisations, however, certain insight was also gained regarding stable measurement conceptualisations.

7.5.1 Stable conceptualisations

For many students, speed as a rate was a stable measurement conceptualisation. Recognising that the quantity to be measured involved the passage of time, most began to use everyday terminology associated with speed when attempting to verbalise what they observed. They described the flow rate as being 'slow' or 'fast' rather than 'low' or 'high', showing a tendency to generalise this understanding to other rates.

Most students also showed a stable conceptualisation of the method to calculate rates. Very few attempted to calculate the flow rate per unit volume rather than per unit time. It is possible that having made a link from the concept of speed to the new concept of flow rate that this ability to symbolically calculate a rate generalised to flow rate. The full understanding, however, did not generalise, as students found it challenging to compare flow rates according to the measured value.

A further stable conceptualisation that became clear as the students engaged in the task, was an understanding of the relationship between pressure and flow rate. Students repeatedly used gestures demonstrating that increased pressure in the system would increase the flow rate.

7.5.2 Emerging conceptualisations

The power of this task was in the view it permitted of the development of a concept. Flow rate was not a stable concept for any of the students interviewed, yet their conceptualisation of it showed evidence of substantial development. The sophistication and accuracy of their explanations improved through the interview and gave evidence of growing stability in their understanding of, and ability to work with, the concept of flow rate.

7.5.3 Additional insights

This task was designed to assess the measurement conceptualisation of flow rate for these students. Because it would be a concept that they would not have met in formal schooling, four subtasks were included to maximise access for the interviewer to these conceptualisations. It was not anticipated that it would prove to be such a powerful method of formally introducing

the concept. This knowledge is not assumed to yet be stable, but for the majority of the students there is evidence that it is much closer to stability as a result of this interview.

7.5 SUMMARY

The observations made in this interview have revealed the conceptualisations held by the students regarding flow rate. In addition, it has provided a vehicle for these conceptualisations to mature towards stability. This suggests that such a structuring of engagement with measurement activities holds power in promoting the construction of accurate and stable measurement conceptualisations, and, importantly, in terms of measurement more complex than spatial measurement.

CHAPTER 8

PRESENTATION AND ANALYSIS OF DATA: INTERVIEW 4

8.1 INTRODUCTION

In this chapter, data from the fourth task-based interview will be presented and analysed. As described in Chapter 5, this task involved students collaborating to solve a practical problem involving the calculation of area. The chapter opens with a description of the process of summarising and analysing these interviews.

Thereafter, data pertaining to the students' performance in the interviews will be presented. Each interview will be described with reference to critical incidents that occurred, which includes the coded moments of interviewer mediation. Finally, a brief discussion will be presented regarding the performance of the full group of students for each of the five phases into which the task was divided.

8.2 PROCESS OF SUMMARY AND ANALYSIS

Due to contextual constraints (see section 4.4.1.3), there were insufficient students available from the original group of 27 to participate in pairs in this interview. For this reason, a key member was selected for each interview from those available of the initial group. This student selected a peer that had not been involved earlier in the study.

The main focus in the analysis of the interviews was the performance of the key member. This focus allowed a comparison to be made between this student's performance in Task 1 and Task 4. In both interviews, students were required to measure and calculate area, but the dominant distinguishing feature of this task was the richness of the contextual information provided and the addition of a peer with whom to collaborate. When analysing this student's performance the peer was viewed as an additional resource, or tool, for the key member. When examining the interviews it was possible to see how they had used this resource and to what extent it had, or had not, been helpful to them.

It is recognised, however, that one cannot analyse the interview by looking solely at the key member's performance. The presence of another student leads to the creation of a uniquely functioning unit, the dynamics of which cannot be ignored. Observations were therefore also made with regard to how the students functioned together in order to solve the problem posed.

This complexity introduced by this design decision serves the aims of the research in providing another type of viewpoint from which to assess each student's measurement conceptualisations.

For the purpose of analysis, the task was viewed as consisting of five phases:

- Phase 1: measurement, calculation and interpretation of area of rectangular houses
- Phase 2: measurement, calculation and interpretation of area of hexagonal restaurant
- Phase 3: measurement, calculation and interpretation of area of circular restaurant
- Phase 4: measurement, calculation and interpretation of area of hotel
- Phase 5: combining results from Phases 1 – 4 to provide a final answer to the overall problem

8.3 DATA PRESENTATION AND ANALYSIS

This section will comprise three main parts. The first data to be presented will be a general comparison of the students' performance in Task 1 and Task 4, for the key member in each interview, with regard to the number of moments of mediation required to complete the tasks, and the highest level of mediation required.

This comparison will be followed by a summary of each interview, with a breakdown of which phase mediation was required in, and the levels of this mediation. While the focus of the observations and analysis was predominantly on the key member, observations regarding the functioning of the students as a unit are included in each interview summary.

Finally, data is collated across interviews according to task phase. Each phase is summarised by providing a count of the number of moments of mediation per level of mediation, across all ten interviews, and a discussion of the general performance of the students in each phase follows.

8.3.1 General comparison of performance between Tasks 1 and 4

The table below summarises the number of moments in which mediation from the interviewer was required, and the highest level of mediation offered for Task 1 and Task 4. The information included in squared brackets pertains to the mediation from the peer during the course of the task, in terms of number of moments and the highest level thereof. We will first consider

interviewer mediation and will discuss the mediation that occurred as the pair collaborated in each interview summary.

Table 8.1 Number of moments and highest level of mediation: Task 1 vs Task 4

	Moments of mediation (Task 1)	Moments of mediation (Task 4)	Highest level of mediation (Task 1)	Highest level of mediation (Task 4)
NDILEKA	10	9 [+1]	F(c)	E(c) [E(m)]
MZWAKHE	10	9	F(c)	E(c)
NOBUHLE	3	3 [+2]	F(m)	D(m) [E(m)]
SISIPHO	3	8	F(c)	D(c)
NTANDO	8	7	E(m)	F(c)
NELISWA	2	11	D(c)	E(c)
AVIWE	1	12 [+ 2]	D(c)	F(m) [E(c)]
SANDLA	3	12 [+1]	F(c)	F(c) [E(m)]
KADEN	5	11	F(c)	F(c)
MALUSI	2	20 [+ 1]	F(c)	F(c) [E(c)]

When compared to Task 1, Ndileka, Mzwakhe and Ntando required fewer moments of mediation in interview 4 to complete the entire task. In addition, Ndileka and Mzwakhe required a lower level of mediation for Task 4. Ntando, however, required a higher level of mediation for Task 4 than for Task 1. Nobuhle required the same number of moments of mediation for Task 1 and Task 4, and required a lower level of mediation for task 4 than for task 1. Nobuhle also dropped in terms of the highest level of mediation she required from high level explicit mediation [F(m)] in interview 1, to implicit mediation [D(m)] in interview 4.

Sisipho required more moments of mediation in order to complete task 4, but similar to Nobuhle, improved to require only implicit mediation [D(c)] for this task. She had required the highest level of mediation [F(c)] in order to complete Task 1.

Neliswa and Aviwe showed both an increase in the number of moments of mediation required for Task 4, as well as an increase in the level of mediation they required. Sandla, Kaden and Malusi required the highest level of mediation for Task 1 and Task 4, as well as increasing in the number of moments of mediation required for successful completion of Task 4.

In order to understand this data it needs to be remembered that Task 4 consists of five substantial task phases. When this is taken into consideration, the increase in the number of moments of mediation for these students in interview 4 is understandable. Only Neliswa, Aviwe and Malusi required close to, or more than, five times the number of moments of mediation for Task 1.

In the following section, the moments of mediation are separated out into the various phases of the task. This allows a more nuanced picture to emerge from the otherwise amorphous data of precisely when students required interviewer mediation, and what form this took. When separated out in this way, it becomes possible to see that there were areas of strength for each group of students.

8.3.2 Analysis of performance per interview

In this section, data from each individual interview will be presented. The number of moments of mediation, and the level of each of these moments, have been split into the phases in which they were provided. This data will be presented in table form, alongside the same data from Task 1, in order to facilitate a comparison between the two tasks.

Each table of data will be followed by a narrative of the critical incidents in that particular interview. It is through the narratives that several patterns and themes become clear.

As the primary focus for analysis is on the key member of the pair, mediation is analysed from that perspective. In the course of collaborative work, there are countless moments of interaction that could be viewed as constituting mediation. For this research, it was the moments of explicit mediation in which the peer mediated for the key member that have been noted.

8.3.2.1 Interview summary – Ndileka

Ndileka was the student who struggled the most with Task 1 (see Section 6.3.2.2). She was offered additional artefacts (tiles) to assist her, yet still required 3 moments of mediation at the highest available level. In her case, the task was abandoned as she was unable to move forward despite the nine mediation attempts.

As is evident in the table below, this was not the picture that emerged for Task 4. To get started on the problem solving with Phase 1, this pair required only one moment of interviewer

mediation, and this only at an implicit level. Phases 3 and 4 required no mediation at all, and the only moment of explicit interviewer mediation was in Phase 5.

Table 8.2 Summarised moments of mediation per task phase: Ndileka

	A	B	C(m)	C(c)	P(a)	D(m)	D(c)	E(m)	E(c)	F(m)	F(c)
TBI 1		1		2	1		1	1	1		3
Phase 1							1	1			
Phase 2			1		1		1				
Phase 3											
Phase 4											
Phase 5				1	1		2		1		

During Phase 1, there was one example of mediation provided by Ndileka's partner. Ndileka had hesitated to start engaging in the task, and her peer intervened with method-level instruction to facilitate her participation.

During Phases 2 to 4, the two worked together effectively. Her partner took charge of directing the process, but only in implicit ways. Ndileka contributed equally to the task during these phases, particularly when the pair needed to recall formulae. By Phase 4 they were seamlessly sharing roles by taking turns to physically measure the required dimensions of the shapes and a lot of debate occurred between the two as they worked on this phase. Ndileka showed an immense amount of progress when compared to her performance in Task 1.

The mediation provided in Phase 1 concerned the use of units in the calculation. The students converted the measured centimetres into metres prior to calculating the area of the houses, but were reporting their solution in cm^2 . They required simply a leading question in order to draw their attention to their choice of units and they then self-corrected their error.

In Phase 2, the students attempted to recall the formula for the area of a triangle, but required the artefact card containing this formula to be provided. The other mediation provided in this phase aided the students in recognising the subdivisions of the hexagonal shape of the restaurant.

Phase 3 required no mediation. The students recalled the formula very easily and calculated the area of the circular shape without little effort. Phase 4 was a challenge. While the students required no mediation from the interviewer, they took some time to work out how to approach

the problem, during which there was much debate between the two peers. They settled on a strategy before starting to measure and calculate.

The debate and discussion between the students continued throughout this phase. They decided in advance how to subdivide the hotel area into rectangles, without gaps or overlaps. However, while measuring and calculating, an error was made in which two rectangles were overlapping. Through debate and discussion the students were able to successfully self-correct this error.

Mediation in phase 5 concerned the use of the scale of the map. In Phases 2 – 4, Ndileka and her partner had chosen to calculate the area of the buildings using cm^2 . These therefore needed to be converted to m^2 in order to arrive at the final cost of building the resort. The following exchange between the interviewer and Ndileka occurred:

Interviewer: How do we convert all of these answers to m^2 ?

Ndileka: I think times 1000

I: [artefact card given: 1cm on the map \rightarrow 7 metres in reality]

N: times by seven!

I: times what by seven?

N: the answer? [points to the calculated area of the hexagon in cm^2]

In this exchange it is clear that the student confused metric conversions with the use of the map scale. In Phase 1 these students correctly multiplied by 7 in order to convert the measured lengths in centimetres to metres. They had not recognised that this differed from converting square measurements. They required instruction [E(c)] in order to realise how to do this. This was the only time that explicit mediation was required.

The dramatic improvement in performance from interview 1 to interview 4 could not be explained by Ndileka not participating in the problem-solving process. Both students played an equal role in the process. The opportunity to collaborate with a peer, and the provision of a richer, and more realistic, context to the problem would therefore appear to have been of benefit to Ndileka.

8.3.2.2 Interview summary – Mzwakhe

Mzwakhe required a large amount of mediation for the first task, half of which was at an explicit level. As can be seen in the figure below, the number of moments of mediation required was fewer for Task 4, with only one moment being explicit.

Table 8.3 Summarised moments of mediation per task phase: Mzwakhe

	A	B	C(m)	C(c)	P(a)	D(m)	D(c)	E(m)	E(c)	F(m)	F(c)
TBI 1			1			3	1	1	1	1	2
Phase 1			1								
Phase 2						1	1				
Phase 3			1						1		
Phase 4			1	1			1				
Phase 5			1								

What characterised the working of this pair was the seamless sharing of responsibilities. The students switched roles repeatedly by alternating who would measure, who would calculate and who would write the working out and solutions down. There was a lot of talk between the students as they solved the problem.

Through talking to each other, the students drew on one another's knowledge and abilities in order to optimally approach the problem. This was a pair who paused to strategise before starting the problem, and they were very methodical about following this plan. They calculated to m^2 for each phase and decided to delay converting to a monetary value at the end. By talking to one another throughout, it was also observed that the students noticed errors shortly after they were made and were able to correct these before any mediation needed to be offered. They sought reassurance [B] from one another as they worked.

The only explicit mediation that was required was regarding the conversion of centimetres squared to metres squared. The students had converted the linear measurements prior to calculating the area in phases 1 and 2, but had calculated the area of the circle in Phase 3 in centimetres squared. It took explicit mediation to assist them to see that the solution needed to be multiplied by 7^2 , and not 7 as was previously appropriate.

The pair made only one error that was carried forward and addressed at the conclusion of the interview. This was to use the measurement of a side of a triangle, rather than its perpendicular height, when calculating the area of the hexagonal restaurant in phase 2. This was resolved with a simple method-level leading question [D(m)].

8.3.2.3 Interview summary – Nobuhle

Nobuhle and her partner performed excellently in this task. She was of the students who required very little mediation in task 1, and this also the case for Task 4. As is evident in Table 8.4, the total number of moments she required in task 1 matched the total number of moments she and her partner required for task 4, despite there being five substantial phases to Task 4. Three phases required no mediation at all.

The highest level of mediation also dropped from explicit to implicit mediation. This pair made no errors and did not require any additional artefact cards. They required fewer moments of mediation than any other student group, and the highest level of mediation that they required was also lower than for all the other student groups.

Table 8.4 Summarised moments of mediation per task phase: Nobuhle

	A	B	C(m)	C(c)	P(a)	D(m)	D(c)	E(m)	E(c)	F(m)	F(c)
TBI 1		1				1				1	
Phase 1											
Phase 2		1						1			
Phase 3								1			
Phase 4											
Phase 5						2					

What distinguished the work of these students was their excellent ability to collaborate and work as a unit. Without discussion as to who should take the lead, Nobuhle’s partner became the one to lead the problem-solving process. It was not that this student took over, although there were two moments in which she voiced what was classified as method-level instruction, but each student contributed equally and there was much talk between the students during all phases. Rather, the role that Nobuhle’s partner took was to keep them focused on their mutually decided strategy.

Before starting the task, the students carefully read the question several times, and then examined each shape that they needed to work with. They established what the required formulae were and decided the order in which they would complete the phases.

The students were very methodical, precise and neat in their working. The page on which they were recording the calculations was well organised, with an area set aside for each phase. They

checked their answers before moving on to the next phase, and were able to identify small calculation errors where they occurred and self-correct these without mediation.

Nobuhle was certainly one of the better-performing students in interview 1 and it was therefore expected that her and her partner would be one of the better-performing pairs in this interview. The strength of the pair's work did not simply arise from the ability of the individuals. Their excellent collaborative ability, which enabled them to remain focused and organised, can also be considered to have contributed to their success.

8.3.2.4 Interview summary – Sisipho

When comparing Sisipho's performance in Task 1 and Task 4, it is clear by examining Table 8.5 that there was an improvement. She required the highest available level of mediation for the first task, while she and her partner required only method-level instruction in Task 4.

Another indicator of this improvement in performance is that it is only in Phase 4 that the students required the same number of moments of mediation as Sisipho needed for Task 1. Phases 1 to 3 required only one moment each, and the pair managed to complete Phase 5 without any mediation.

There were two small errors made (one each in Phases 2 and 4) for which mediation was delayed until the end of the interview. The pair also required the provision of the formula $[P(a)]$ for calculating the area of a triangle as they worked on Phase 2. In Phase 3 the students used the length of the diameter of the circle, rather than the length of the radius, in their calculation. This required simply a method-level prompt to resolve. In Phase 4 the students left out one rectangular piece of the hotel when adding the components to find the total area. This was the only time explicit mediation was required for this pair.

Table 8.5 Summarised moments of mediation per task phase: Sisipho

	A	B	C(m)	C(c)	P(a)	D(m)	D(c)	E(m)	E(c)	F(m)	F(c)
TBI 1		1					1				1
Phase 1			1								
Phase 2					1		1				
Phase 3			1								
Phase 4		1					1	1			
Phase 5											

This pair worked in a similar way to Nobuhle and partner. They were very deliberate about examining the problem as a whole very carefully and arriving at a complete strategy before starting to work. In the first two phases they referred to the artefact card containing the question several times to keep orienting themselves to the problem as a whole.

There was a lot of student talk as they worked. There were moments of disagreement between the students in Phase 1, but no interviewer mediation was required to help them to resolve this. They listened to one another's ideas and mutually decided on how to proceed, revealing strength in their ability to collaborate and work as a unit effectively.

8.3.2.5 Interview summary – Ntando

Ntando was very unsure of himself when attempting Task 1. He required a lot of reassurance (B) as he worked, as well as some method-level instruction [E(m)], in order to arrive at a solution. In Task 4, however, while the pair did require a higher level of mediation in Phase 4, the total number of moments of mediation dropped.

Instead of requiring reassurance from the interviewer, Ntando and partner provided this for each other, thus using one another as a resource. They showed some nervousness at the beginning of the interview and the reassurance they were able to offer one another was important for them to get started.

There was a large amount of student talk and debate as they began to decide on a strategy. They repeatedly referred back to the artefact card containing the question. The students discussed what units they will be using and which part of the problem to start with.

Table 8.6 Summarised moments of mediation per task phase: Ntando

	A	B	C(m)	C(c)	P(a)	D(m)	D(c)	E(m)	E(c)	F(m)	F(c)
TBI 1		4				1		3			
Phase 1											
Phase 2					1		1				
Phase 3											
Phase 4								1			2
Phase 5								1	1		

There was evidence of the students sharing responsibility for the task. They were both reading off the length measurements on the ruler and checked that they were in agreement before writing anything down.

Phases 1 and 3 required no mediation. In Phase 2, the students used the measurement of a side of a triangle, and not the perpendicular height, when calculating the area of the triangles. At the conclusion of the task it was simply a method-level leading question that was required for them to notice and correct the error. The pair did require the artefact card containing the formula to calculate the area of a triangle, but were able to independently recognise the need to subdivide the hexagonal area into triangles and did notice that the six triangles were equilateral.

Phase 4 proved to be challenging. The students did not pause to strategise before each picked up a ruler to start measuring the dimensions of the hotel building. They did not communicate and began to work alongside, rather than together with, one another. Eventually they required the highest possible level of mediation [F(c)] in this phase.

The students had chosen to calculate to cm^2 for phases 1 to 4, and to delay the conversion to m^2 until Phase 5. Here they required brief mediation at the instruction level [E] as they wanted to convert using metric conversions rather than the scale. They were able to quickly complete the phase as soon as they understood how to perform this conversion. They did not require any further assistance in arriving at the monetary value for building the resort, and were able to easily relate their result back to the original context

8.3.2.6 Interview summary – Neliswa

In interview 1, Neliswa used a strategy that was very carefully thought out before she started working. This characterised her work with her partner in this interview. They started by each reading the question silently, speaking softly to themselves and looking from the question to the map repeatedly as they made sense of the context and problem individually. Thereafter, they started to discuss how they would approach the task and formed a strategy before beginning with Phase 1.

While working in Phase 1, Neliswa was heard to say the following to herself: “metres squared is millimetre... 7 metres divide by hundred to get millimetres...R8500 for metre squared so millimetre”. Interestingly, however, the pair went on to correctly convert the measured centimetres to metres according to the scale, and correctly calculated the cost of building the houses, without mediation. Neliswa seemed to be confusing the algebraic simplification of mm to become m^2 , as well as referring to the metric system of conversion (“divide by hundred”), at the same time as trying to make sense of the scale (“7 metres”).

It would appear that verbalising this assisted her in working out how to use the scale, as neither her partner, nor the interviewer, needed to respond in any way for her to spontaneously begin to use the scale appropriately. As is shown in Table 8.7, this pair required no interviewer mediation in this phase.

Table 8.7 Summarised moments of mediation per task phase: Neliswa

	A	B	C(m)	C(c)	P(a)	D(m)	D(c)	E(m)	E(c)	F(m)	F(c)
TBI 1		1					1				
Phase 1											
Phase 2		1			1	1			1		
Phase 3		1			1			1			
Phase 4		1							1		
Phase 5							1	1			

Most of the mediation required by these students was at an implicit level, and the majority of this was simply reassurance. They did request assistance with recalling the formulae to calculate area. The artefact cards with the triangle and circle formulae needed to be provided.

They used the length of the diameter, rather than the radius, in the calculation of the area of the circular restaurant.

They lost confidence somewhat in Phase 4, as they sought a moment of reassurance that they were using the correct formula to calculate the area of a rectangle. They had used this previously in Phase 1, and it should therefore not have required mediation. It was possible that the request for reassurance was about whether or not they could subdivide the shape into rectangles to calculate the total area.

The students independently completed Phase 4 with the only error being that they had added one section twice to arrive at the solution for the whole area. This was the reason for the provision of one moment of instruction-level [E] mediation.

While the students had decided to convert to rand at each phase, this was not done throughout. In Phase 1 the pair calculated to the final answer in rand, in Phases 2 and 3 they stopped when they had arrived at the area in m^2 , and in Phase 4 they stopped when they reached the answer in cm^2 . They had therefore already demonstrated that they could perform the cost calculation, and the conversion from centimetres to metres according to the scale. The mediation provided in Phase 5 concerned the conversion of cm^2 to m^2 , which was necessary in order to arrive at the cost to build the hotel.

When examining Table 8.7, it does appear that this pair struggled. There are nine moments of mediation, much more than the two that Neliswa required for Task 1. If the performance is examined per phase, however, there is a more positive picture. Only one phase required more than two moments of mediation.

Much of the mediation was reassurance [B], and as reflected on above, there were times when the pair seemed to lose confidence. Mediation therefore had a large role in helping the students to feel more confident in their choices as they solved this problem.

8.3.2.7 Interview summary – Aviwe

Aviwe arrived for his interview with two peers, therefore three students worked together to complete this task. Aviwe started his first interview sitting back and stating “I don’t know”. One leading question, however, unlocked the task for him and he was able to complete it otherwise independently.

For Task 4, Aviwe and his partners required ten moments of mediation. Only two exceeded the highest level of mediation required by Aviwe in interview 1. The remainder of the mediation remained at the implicit level.

Table 8.8 Summarised moments of mediation per task phase: Aviwe

	A	B	C(m)	C(c)	P(a)	D(m)	D(c)	E(m)	E(c)	F(m)	F(c)
TBI 1							1				
Phase 1		1						1 + 1	1		
Phase 2					1		2		1		
Phase 3					1	1					
Phase 4			2								
Phase 5		1	1								

Despite having three members in this group, which added complexity to how they organised themselves in relation to the problem-solving task, this group was highly organised and worked very well as a team. Prior to starting any work, they discussed how they would approach the problem. They decided to calculate the cost of each building, and not only the area, in each phase. This meant that Phase 5 required simply the adding of the costs already calculated.

They paused at the beginning of each phase in order to again discuss with one another how to perform the calculations. There was a lot of student talk in this interview. They repeatedly returned to the artefact card containing the question and contextual information in order to check their answers in relation to the problem. This formed an important resource for them.

This group struggled to recall the formulae that they needed to calculate all of the areas. While they managed to recall the formula to calculate the area of a rectangle, they needed those for the triangle and circle to be provided.

A lot of the mediation that was required by these students concerned conversions. They required explicit mediation in order to convert cm^2 to m^2 , as well as prompts [C] to do this. There was no need for interviewer mediation for any strategy decisions. For example, the group needed no help to realise the need to subdivide the hexagon in order to calculate its area and decided independently to subdivide the composite area of the hotel.

8.3.2.8 Interview summary – Sandla

Sandla was one of the students who required the highest possible level of mediation for Task 1. When working with his partner in Task 4, there was also one moment at this level, and the remainder of the mediation moments were at least three levels lower.

The total number of moments of mediation was higher for Task 4 than for Task 1, but it should also be noted that per phase this was not the picture. Phases 1, 3 and 4 required an equal or lower number of moments of mediation, with Phase 5 being completed by the pair independently.

Table 8.9 Summarised moments of mediation per task phase: Sandla

	A	B	C(m)	C(c)	P(a)	D(m)	D(c)	E(m)	E(c)	F(m)	F(c)
TBI 1							1		1		1
Phase 1		1									
Phase 3		1			1	2	1				1
Phase 2[#]			2								
Phase 4			2					1 + 1			
Phase 5											

[#] note that phase 2 and phase 3 are reversed in this table; students chose to work in this order

This pair started work before taking time to consider the problem as a whole. They read the question and the contextual information, pointed to each of the relevant buildings on the map and then started working to calculate the area of the houses. Unlike other groups, they did not return repeatedly to the artefact card containing the question during the task.

At the beginning of each phase, Sandla and his partner decided how to measure and calculate the areas. They formed strategies that addressed the problem in parts, without considering what the relevance of each part was to the whole until the final phase.

This was different to most of the pairs already described who considered the question as a whole before deciding how to divide it into parts. For those pairs, there was a long period of student talk before phase 1, whereas for this pair there was a large amount of student talk at the beginning of each phase.

The students started Phase 1 by measuring the dimensions (length and breadth) of one of the houses and adding them together. This confusion between area and perimeter was possibly due to them not having spent as much time as others considering the question and contextual information provided. It was easily resolved once the students noticed their error, with this phase requiring only the provision of reassurance [B] from the interviewer. It was also not repeated in subsequent phases.

Sandla and his partner were one of only three student groups who did not require the artefact card containing the formula to calculate the area of a triangle, nor did they require the card referring to the circle formula.

On reaching Phase 3 (which this pair chose to do before Phase 2), Sandla immediately wrote the formula to calculate the area of a circle, and then paused, unsure of how to proceed. The following exchange occurred as the pair worked to calculate the area of the circular restaurant:

Interviewer: What is 'r'? **[D(c)]**

Partner: That's just it... so we are not supposed to use our textbook?

Sandla: radius

P: [picks up ruler and examines it]

I: To measure it, where would you place the ruler? **[D(m)]**

P: [places ruler to measure from approximate middle of the circle] 1.5

[Students start calculating, using the formula and their measurement of the radius]

I: What unit are you using? **[D(m)]**

P: S'joe, this is hard, we haven't done this for...

S: metres squared

I: [point to ruler]

S: centimetres squared

I: how do we convert to metres squared?

S: [long pause, looking to the ceiling] divide by a thousand and times a hundred

P: times seven [as multiplies by seven and records the solution]

At this point, the interviewer mediated at the highest level to assist the students to realise that it was necessary to multiply by 7^2 , and the artefact card stating this information was provided. The students had, in Phase 1, converted the measured centimetres into metres before calculating the area, and had gone on to do the cost calculation for the houses. For this phase, they had calculated the area in cm^2 and then confused metric conversions with the use of the scale, as well as needing mediation to learn how to convert square units. Importantly, the students did not need further mediation concerning the conversion of units and use of the scale.

The level of mediation required by this pair decreased after the high level required for the circular restaurant calculation, indicating that the students were learning from the mediation as it was provided. There was no reason for repeated mediation on the same topic.

8.3.2.9 Interview summary: Kaden

In interview 1, Kaden rushed to begin without first pausing to consider the problem posed properly. This resulted in the need for 5 moments of mediation, 2 of which were at the highest level possible.

This characterised her work in interview 4 too. The question and contextual information were read quickly, and without discussing the problem with her partner, they moved immediately to begin measuring the dimensions of the houses. Kaden took charge in the interview, making all the decisions, and dictating to her partner what was to be written down. Kaden did use her peer as a resource, but not as someone who could contribute to the solution of the problem, but rather as someone who could keep record of her work.

Phase 1 began in a disorganised fashion, with the dimensions being measured in centimetres, being spoken of in metres and being recorded as millimetres. Interviewer mediation at the highest level was therefore required before the calculations had begun.

Table 8.10 Summarised moments of mediation per task phase: Kaden

		B	C(m)	C(c)	P(a)	D(m)	D(c)	E(m)	E(c)	F(m)	F(c)
TBI 1			2				1				2
Phase 1			1								1
Phase 2			1		1		1				1
Phase 3											
Phase 4		1		1					1		
Phase 5			1						1		

Phase 2 also required high level mediation. Kaden measured one side of the hexagonal shape, multiplied it by six and wanted to move on to Phase 3. It was pointed out to her that this was perimeter. She immediately asked for the formula to calculate the area of a triangle, which was evidence that she did know that the shape should be subdivided and the areas of the triangles calculated and added.

When asked to try to recall the formula, she stated “length times breadth times height”, at which point she was provided with the relevant artefact card. Her next statement was, “how do we do that, if we don’t have height we must use Pythagoras?” She was reassured that this would be correct, but it was also acceptable to measure the height. She traced the height with her finger, indicating that she did know what to measure, but proceeded to measure the length of a side. This required simply a leading question to resolve, but her apparent desire to rush her work was leading to unnecessary errors, and more mediation than should have been required.

Phase 3 was completed without any mediation. In Phase 4, there were again errors that arose due to the rushed nature of her working. Kaden chose to calculate the central square area of the hotel first, but was unsure of the formula needed to calculate the area of the square. She needed reassurance on this. She then chose to measure and calculate the area of the left side of the hotel building and double this, before adding it to the square area. This was an acceptable approach, but she chose to square the left area, rather than multiply it by 2. This was again an error that should not have been made had she slowed down. She was voicing the correct strategy, but was not performing the calculation in the same way.

This pair did not function as a unit. There were moments in which Kaden’s partner attempted to intervene. At each of these moments, although he was correct in what he offered, his ideas were dismissed by Kaden and frequently a joke was passed between them at these moments about how he was not “good at maths”.

In Phase 5, she returned to the question and contextual information without any need to prompt her to do so. The mediation provided here concerned the conversion of cm^2 to m^2 , as was the case for many of the pairs already described.

If Kaden had performed the calculations in the same way as she was narrating her process, and had she chosen to give consideration to her partner’s ideas, the number of moments of mediation, as well as their level, would have been lower.

8.3.2.10 Interview summary – Malusi

Malusi did not require many moments of mediation in interview 1, although he did require one at the highest level. In interview 4, however, he and his partner required 18 moments of mediation, the majority of which was explicit, and 5 of these were at the highest possible level.

Table 8.11 Summarised moments of mediation per task phase: Malusi

	A	B	C(m)	C(c)	P(a)	D(m)	D(c)	E(m)	E(c)	F(m)	F(c)
TBI 1							1				1
Phase 1				1				1	1 + 1		2
Phase 2			1	1	1		1	[1]			1
Phase 3					1				1		1
Phase 4				1			1		1		[1]
Phase 5						2					

This pair read and reread the question and contextual information many times, before discussing with one another how to start working. When they started the work, however, they seemed to be working alongside one another rather than together. There was a lack of organisation evident, with each student measuring different lengths on different shapes and recording them haphazardly on the page provided.

The students required the artefact cards containing the formulae to calculate the area of a triangle and a circle. They also required high level mediation to keep them focused on area rather than perimeter, and to keep them focused on calculating the inside area of the shapes, and not the area outside the hotel building, or between the houses.

The aspect of the problem which most students required assistance with was the use of the scale when converting square units. Despite the challenges these students faced in solving this task, it is noteworthy that there was only one moment of mediation [E(c)] required to address this. Subsequent to this moment, the pair used the scale correctly without any mediation.

In phase 5, this pair only required two moments of implicit mediation. This was a marked difference to the amount of mediation required in the previous four phases. Despite requiring much interviewer mediation to calculate the areas, once calculated they were able to relate these solutions back to the context and interpret them in relation to the question asked.

8.3.2.11 Summary

Each of the pairs showed slightly different ways of interacting while working on the measurement task, but what stands out for most is the improvement evident during the course of the task. When examined as an individual, with the partner as a type of resource, most students showed improvement on their performance from Task 1. Alternately, when viewing

the pair as a unit, development was apparent from the start of the task in Phase 1, to its conclusion in Phase 5. This is discussed further in Section 8.4.

8.3.3 Analysis of performance per task phase

As the summary and analysis of each interview unfolded and the themes began to emerge, it became clear that some phases may have been more challenging than others. For this reason, each phase was summarised according to the number of moments of mediation, and the distribution of the levels of these moments, across all ten interviews.

8.3.3.1 Mediation in Task Phase 1

In Phase 1, students calculated the area of the houses on the resort property. All students made the (correct) assumption that all 19 houses were equal in their dimensions, which simplified the problem to one in which only one rectangular area had to be calculated. None of the students checked to verify that this assumption was correct. In terms of task demands, this phase was the least challenging of the five. Figure 8.6 shows that the majority of mediation was provided at an implicit level.

Figure 8.1 Moments of mediation and levels of mediation: Task 4, Phase 1

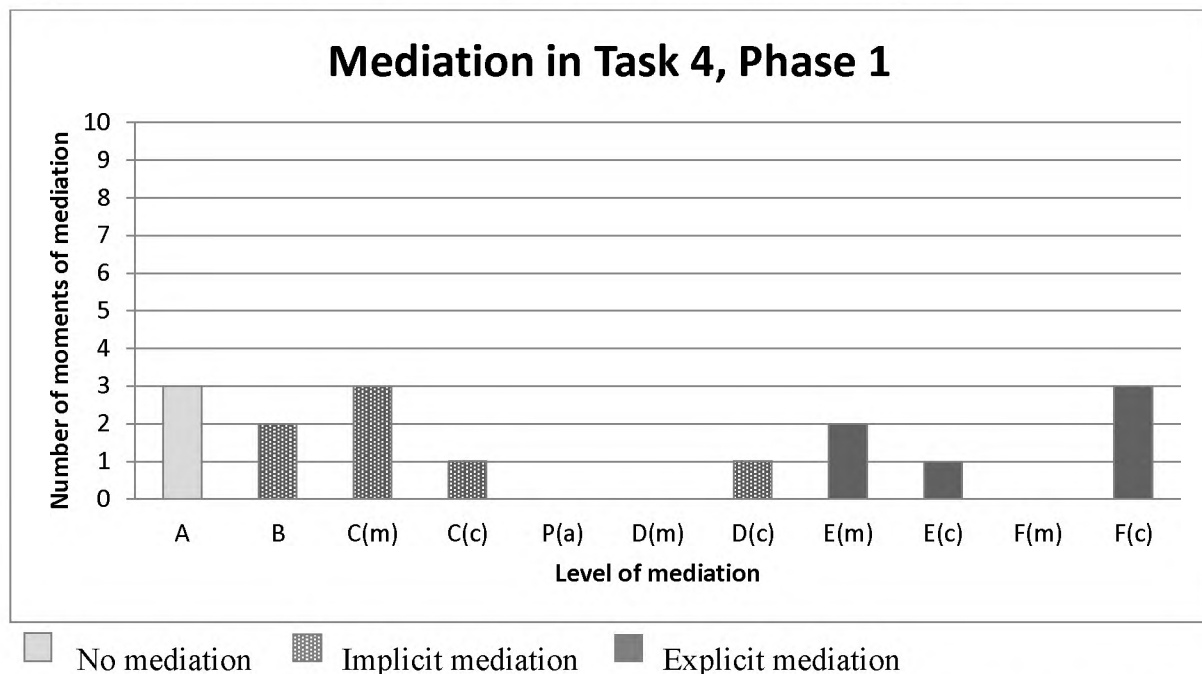

Three groups of students required no mediation in this phase (Nobuhle, Ntando and Neliswa). They were those who formed a strategy for solving the question as a whole prior to beginning any phase of the task. There were no groups of students who required the formula to calculate the area of a rectangle to be given to them.

There were six examples of explicit mediation in this phase. Only three groups of students required this level of mediation (Kaden, Aviwe and Malusi). In the case of Kaden and Aviwe, mediation was provided concerning the use of units.

Malusi’s interview accounted for 4 of the 6 explicit mediation moments for this task. He and his partner began the phase before spending time arriving at a strategy for solving the problem, and were therefore grappling with strategising and organising themselves while at the same time attempting to work on the phase.

With the exception of only Malusi and peer, the students’ body language showed that they were relaxed and comfortable working in this phase. It was also the phase for which the answers provided by the students were most accurate.

8.3.3.2 Mediation in Task Phase 2

In phase 2, students calculated the area of the hexagonal restaurant. Part of the challenge of this phase was to notice that the hexagonal shape could be subdivided into triangles. Calculating the area of a triangle was prior knowledge that students were expected to have mastered on entry to the course. Calculating the area of a hexagon was not. Much of the implicit mediation provided concerned students recognising this subdivision.

Figure 8.2 Moments of mediation and levels of mediation: Task 4, Phase 2

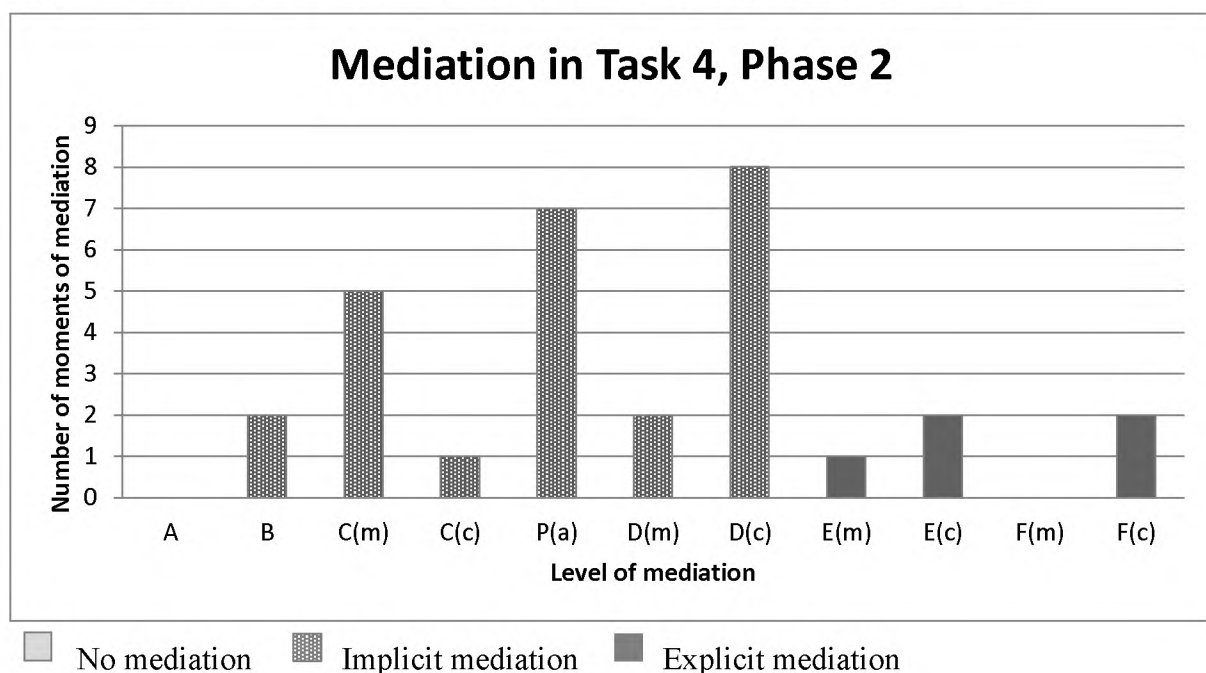

Phase 2 stood out as the phase in which the most *artefact cards* [P(a)] were required. Seven of the ten student groups required the artefact card providing the *formula* for calculating the area of a triangle.

There were 5 errors that were carried forward to later phases. All of these were regarding the substitution of the length of a side of a triangle rather than the perpendicular height in calculating the area of each triangle making up the hexagonal area.

While the large majority of the mediation provided was at an implicit level, the total number of moments of mediation in this phase was notably higher than in the first phase. No student groups were able to do this phase of the task without some form of mediation from the interviewer. This was the only phase for which that was the case.

8.3.3.3 Mediation in Task Phase 3

Task Phase three required students to calculate the area of the circular restaurant. Student needed to recall the formula to calculate the area of a circle, as well as needing to measure the length of the radius of the circle.

Figure 8.3 Moments of mediation and levels of mediation: Task 4, Phase 3

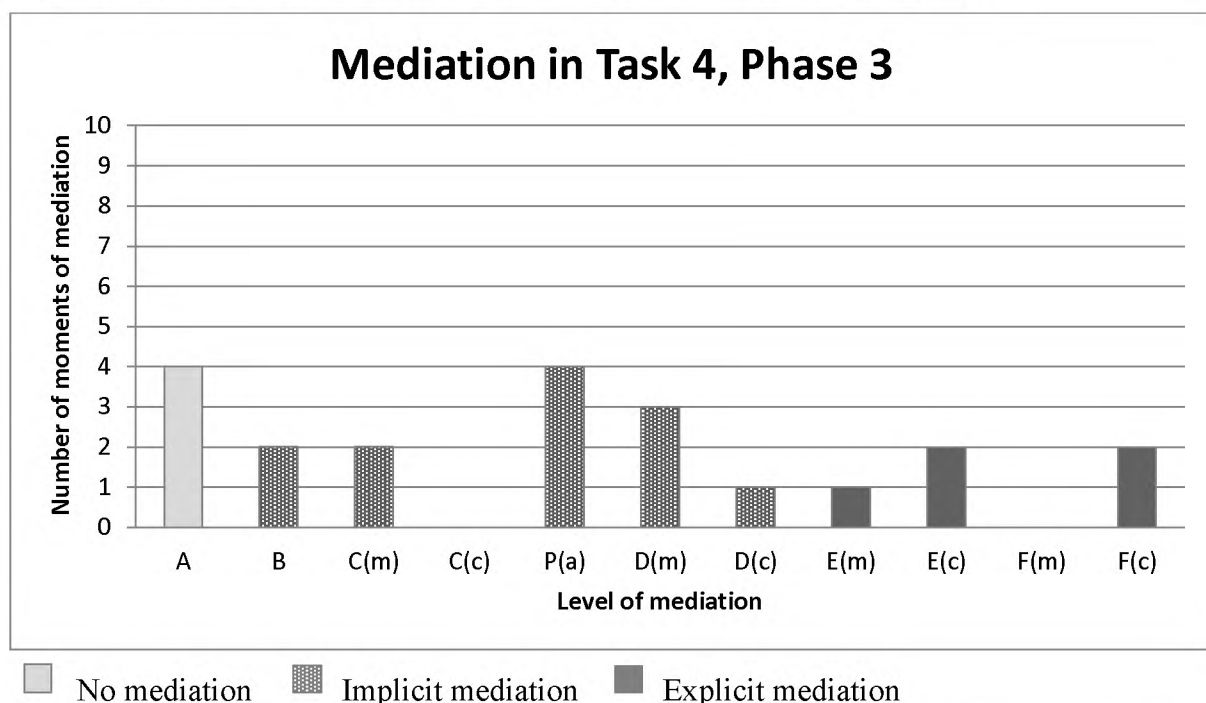

With the difficulties faced by students in recalling the *formula* to calculate the area of a triangle, it was surprising to note that only three student groups failed to recall the formula to calculate the area of a circle. It was also anticipated that more students would erroneously use the

diameter measurement in their calculations. In fact, only two student groups showed this error in their working.

Four student groups managed to complete this phase with no mediation from the interviewer. While moments of explicit mediation were the same for task phases 2 and 3, there was a sizeable drop in the number of implicit mediation moments required. In total, the number of moments of mediation dropped from 23 in phase 2 to 13 in phase 3. This matches the 13 moments for phase 1, and places these phases as being those requiring the least mediation.

8.3.3.4 Mediation in Task Phase 4

Task Phase 4 saw students calculating the area of the hotel building. This was a composite rectangular shape, and required students to pause and *strategise* before starting. There were a number of ways in which to subdivide the shape into rectangular areas, and students needed to be careful not to allow any gaps or overlaps when doing so.

Figure 8.4 Moments of mediation and levels of mediation: Task 4, Phase 4

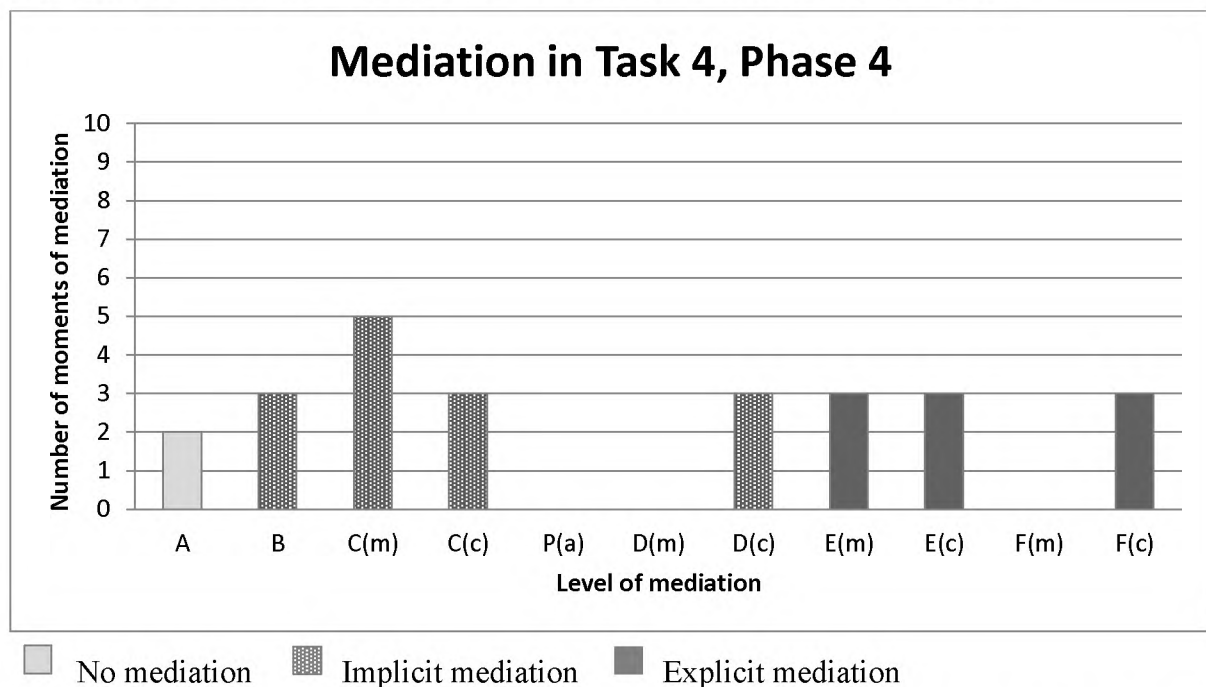

It was established earlier in the task that students could calculate the area of a rectangle, therefore the major difficulty in this phase was the added complexity of making the subdivisions. It was clear that this was a challenge when comparing Phase 1 to Phase 4. Phase 1 required only 13 moments of mediation, while phase 4 required 23 moments. It was also the phase in which the most explicit moments of mediation were required.

It was anticipated that students may either overlap rectangular areas, therefore arriving at an answer that was too high, or would leave areas out of their calculation, therefore arriving at an answer that was too low. There were two examples of each of these errors, and one group of students did not manage to independently complete the phase (Malusi).

There were students, however, who were very successful in this phase. Two groups required no mediation at all, and there were five student groups who were able to arrive at an accurate solution, albeit with mediation.

8.3.3.5 Mediation in Task Phase 5

Task Phase 5 required students to relate the solutions from Phases 1 to 4 to the problem as a whole. The overall question concerned the cost to build the resort, therefore the final solution was to be a monetary value.

Some students showed an awareness of this final requirement throughout their working in earlier phases. They chose to calculate the cost of each building as they moved through the problem, and did not leave this until the end.

There was no correct or incorrect way in which to approach the question as a whole, but those students who opted to calculate the final monetary value as they worked did seem to benefit from doing so. Malusi, Aviwe and Sisipho are three students who showed this *strategy* in their working, and all three required far fewer moments of mediation in this phase than the previous 4 (see Tables 8.5, 8.8 and 8.11). Malusi's performance in this final phase is the most remarkable. From requiring the most mediation of all student groups for this task, the majority of which were high-level, explicit mediation moments, he and his peer required only implicit mediation for this phase.

Figure 8.5 Moments of mediation and levels of mediation: Task 4, Phase 5

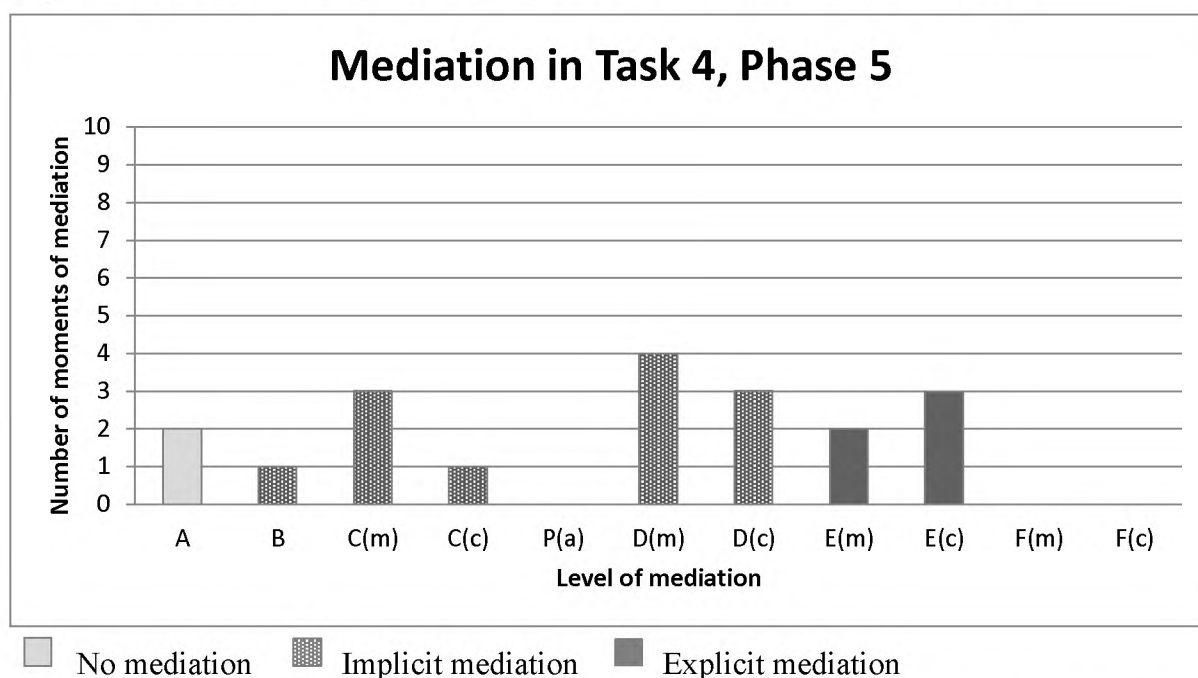

A further observation for this phase was that the highest two levels of mediation (F(m) and F(c)) were not required. In fact, the majority of mediation was implicit, and for every group of students, the mediation required for Phase 5 was lower than they had needed in Phases 1 to 4.

8.3.4 Summary

If performance is separated out according to the task phases for the full group of students, a pattern emerges with regard to which task phases required the least or most mediation. This allows a view of the phases that suggests certain measurement conceptualisations to be more stable than others. This is discussed further in the section that follows.

8.4 STABLE AND EMERGING CONCEPTUALISATION

The complexity of this task resulted in the students needing to make use of a large number of measurement conceptualisations and bring them together into an integrated task. An observation of the students as they worked through the phases of this task allowed some insight into the relative stability or instability of these conceptualisations.

8.4.1 Stable conceptualisations

The ability to calculate the area of a rectangle is stable for these students. Their ability to recall the formula to do so was reliable, and most immediately measured the correct dimensions of

the shape and arrived at the correct solution. This was not the case for the other shapes, particularly the triangle.

The remaining conceptualisations required for this task revealed themselves to be emerging, as is discussed below.

8.4.2 Emerging conceptualisations

Students required a particularly large amount of mediation regarding the use of units, scale and the recall of formulae.

Mediation was required for some when converting the centimetres measured with the ruler to metres according to the scale. Most pairs, however, performed this calculation without difficulty. What provided a challenge to many was the conversion of cm^2 to m^2 where they had calculated the area of the shape with the measured lengths. Only Aviwe and Malusi, however, required more than one moment of mediation regarding this. For the remainder, one explanation was sufficient for the group to apply what they had learned to the phases that followed. The use of square units, therefore, can be considered emerging, as evident in students' engagement with this task.

It was anticipated that students may require assistance regarding the formulae required to calculate the areas of the buildings, however, this knowledge would have been school-met for all students interviewed. From Grade 5 and Grade 6 level, learners start to use formulae to calculate the area of rectangles, squares, triangles and circles. It was therefore interesting to note that the recall of these formulae was as challenging as it was for them. It is perhaps because they are used to being provided with a formula sheet, but as is discussed in Chapter 9, this does not mean that they are able to identify the correct formula to use. Once provided with the formula, however, the students were able to swiftly and accurately calculate the desired measurement. This does suggest that the link between the real-world, embodied context in which measurement takes place, and the symbolic formal world in which measurements are calculated according to formulae and definitions is unstable.

One particular shape was found to be problematic for the students: the triangle. Eight of the ten groups required the artefact card containing the formula for calculating the area of a triangle, as opposed to only three requiring the equivalent card for the circle and none requiring the card for rectangular areas.

8.4.3 Additional insights

Several additional insights were gained through analysis of students' engagement in Task 4. These are discussed in the sections that follow:

8.4.3.1 The influence of the key member's performance in Task 1

In analysing the difference in performance from Task 1 to Task 4 one notices that the performance of the key member in Task 1 was not a predictor of the performance of this students' group in Task 4. A comparison of the number of moments of mediation, and the highest level of mediation offered, for Task 1 and Task 4 was presented in Table 8.1. This revealed that for 5 key members the number of moments and/or highest level of mediation dropped from the first to the fourth task. This was despite Task 4 consisting of five phases in comparison to the equivalent one in Task 1. With the exception of Aviwe and Malusi, none of the students required more than 5 times the number of moments of mediation for Task 1, as would be reasonable to expect.

8.4.3.2 Student talk and strategising

There was a large amount of student talk and student debate in most interviews, but a noticeable amount more in the working of more successful groups. The more the students deliberated and discussed how to proceed, the more efficient and organised their working was. When the students listened to one another, and had the opportunity to state their point of view on what to do, they were able to identify which strategy was the most appropriate to take.

Another observation that was made was that most groups spent a lot of time generating a strategy to approach the problem as a whole, before beginning to work on it in parts. Nobuhle and her partner stood out in this regard. They required the least amount of mediation of all student groups and were the group that was seen to be most deliberate about forming a complete strategy before starting to solve the problem.

8.4.3.3 The value of the contextual richness

Task 4 differed from Task 1 in another important way: a rich and realistic context was provided to the problem. Most of the ten interviews saw students returned repeatedly to the card containing the overall question with its contextual information to reorient themselves to the problem. They often did so wordlessly, reading the card and examining the map carefully,

before resuming discussion on what step to take next, or how to resolve an issue that was confusing them. The contextual information was therefore used effectively as a resource.

Phase 5 required students to return to the contextual information and relate their previous solutions to the original question. Even those who had required a lot of mediation in Phases 1 to 4, most notably Malusi and Sandla, showed a vast improvement in Phase 5 (see Tables 8.9 and 8.11). Sandla required no assistance for Phase 5, and Malusi required only two implicit moments of mediation. The rich and realistic context framed the problem in a comprehensible and relatable way, which helped these students to make sense of the final steps in the problem.

8.4.3.4 Evidence of development

There was a certain amount of development evident as the students worked through the task. As noted earlier, many pairs required mediation concerning how to use the scale of the map, but only two groups required more than one such moment. This suggests that there was learning that occurred and students gave evidence of this when they used the same information accurately later in the problem.

8.5 SUMMARY

This chapter presented the data that emerged from an analysis of task-based interview 4. Ten student groups participated in this interview. Students collaborated to solve a practical problem involving the calculation of the area of a resort. There was a rich context provided to the question posed in order to create a task that could be realistically expected in a workplace.

The ten interviews were summarised according to the number of moments of mediation and the highest level of mediation required by the students. This was reported for the task as a whole as well as for each of the five phases of the task in order to provide a more nuanced view of the students' performance.

The focus of the analysis was threefold: the performance of the key member of the student group (the student who had participated in interview 1), the performance of the student group as a unit and the performance in each phase of the task across all ten interviews.

Both stable and emerging measurement conceptualisations became evident, and several additional insights gained.

CHAPTER 9

PRESENTATION AND ANALYSIS OF DATA: FORMAL WRITTEN TEST

9.1 INTRODUCTION

Students were taught about measurement in the third quarter of the year in their mathematics lectures. These lectures were one hour long and were held once a day for a period of two weeks. At the conclusion of this series of lectures, students were required to write a summative assessment in the form of a formal written test. Data from this test will be presented and analysed in this chapter.

The test is described in Chapter 5, and is provided as Appendix Q. The chapter opens with a detailed description of the process of summarising and analysing the data and a presentation of this data will follow.

9.2 PROCESS OF SUMMARY AND ANALYSIS

The test was used by the college to provide a quantitative result reflecting students' mastery of the measurement outcomes in the curriculum. For the purposes of this study, a qualitative approach was taken to the analysis of the students' responses in order to achieve a more finely detailed picture of the students' ability to work with measurement concepts and calculations than a single overall percentage was able to give.

9.2.1 Initial summary and analysis

Each test item required students to first examine the diagram or descriptive text provided in the question paper and then to select the appropriate formula to calculate the desired attribute of the shape. Thereafter, it required the substitution of the appropriate dimensions of the shape into this formula, and then the calculation and reporting of the final solution, including the use of the correct SI unit. Each student response was qualitatively examined by the researcher with regard to what was done in each of these steps.

Before commencing with an analysis of the finer details of the students' performance, the overall results for each student were summarised and interpreted according to the seven-level rating scale prescribed by the DHET (2011, p. 9) in the Assessment Guidelines (DHET, 2011). The scale appears as Table 9.1 below:

Table 9.1 Rating Scale

Rating Code	Description	Percentage
7	Outstanding	80% - 100%
6	Meritorious	70% - 79%
5	Substantial	60% - 69%
4	Adequate	50% - 59%
3	Moderate	40% - 49%
2	Elementary	30% - 39%
1	Not Achieved	0% - 29%

Source: DHET, 2011, p. 9

The student scripts were further summarised according to the marks achieved for each item. They were coded as either ‘full marks’ [F], ‘partial marks’ [P], ‘zero marks’ [O] or ‘not attempted’ [X]. All of the items were assigned more than one mark on the question paper. Students were awarded some of these marks [P] if at least half of their working was correct, despite their final solution being incorrect.

9.2.2 Categories of responses

Items for which students were awarded full or partial marks were examined in order to ascertain how these students were arriving at their solutions. In addition, a detailed analysis of student errors was carried out. In order to achieve saturation (Saumure & Given, 2008) the process of coding and summarising the item by item analysis was repeated until no new categories of errors or methods emerged. This required the process to be carried out twelve times.

Figure 9.1 provides a visual summary of how responses were finally coded and categorised. It is followed by a description of these categories with examples of the students’ work.

Figure 9.1 Emergent categories of test item responses

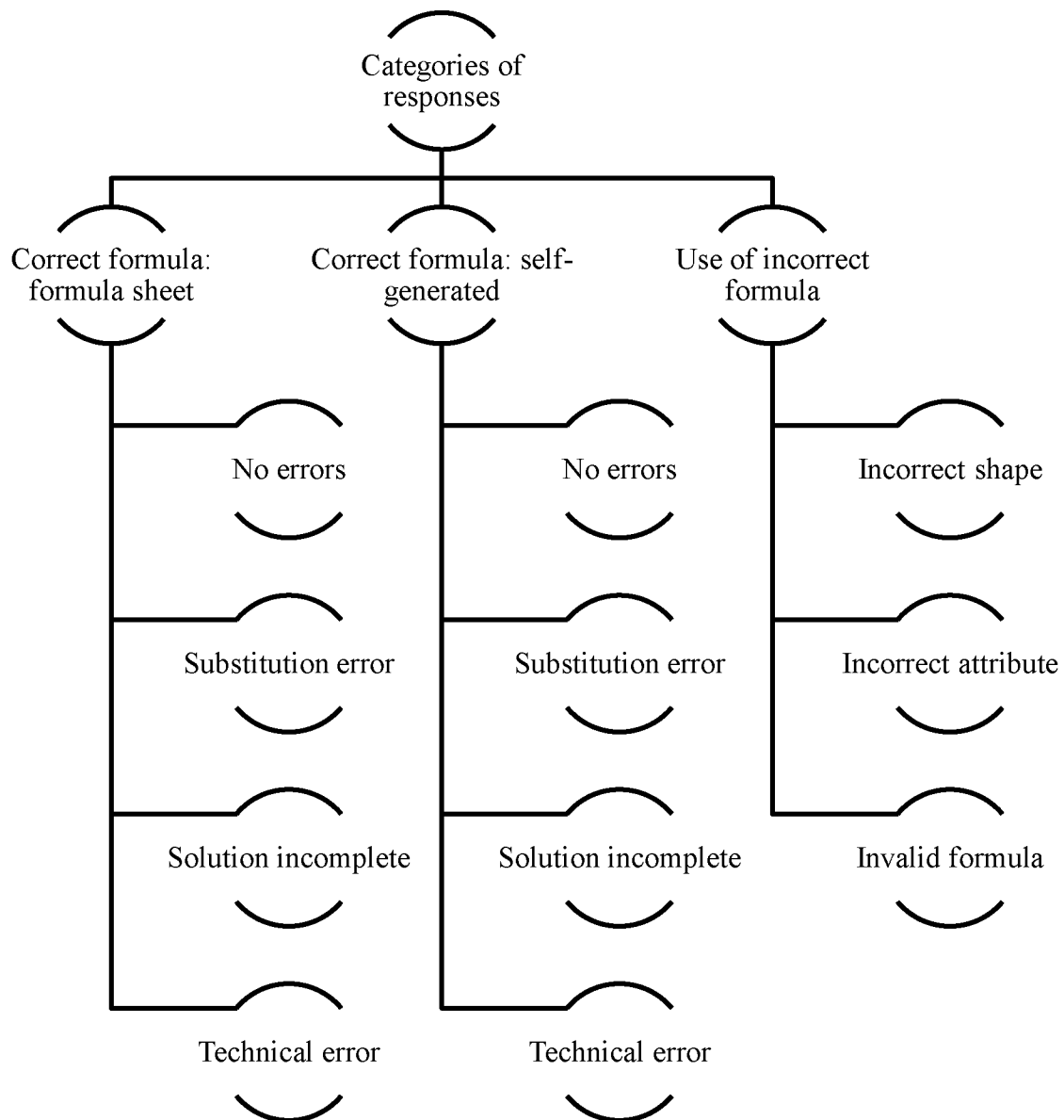

Within the responses, where the correct formulae were used, the source of these formulae was differentiated. The formula had been either taken directly from the formula sheet provided, or generated by the student. Self-generated formulae referred to those that students had either memorised or derived from the formula sheet. For example, the formula to calculate the total surface area of a rectangular prism had not been provided directly, therefore where students had used $A = 2(lb + lh + hb)$, this was considered to be self-generated.

9.2.2.1 Use of formulae

First the students' use of formulae was considered according to whether they made use of the formula sheet (Appendix R) or not, and whether their selection of formula was appropriate or

not. Where the correct formula was used for the first step, the further working of the students was examined according to whether they achieved full marks [F], partial marks [P] or zero marks [O].

Figure 9.2 shows a student's work in which the correct formulae were selected from the formula sheet and they proceeded to achieve full marks for question 1.1. Figure 9.3 shows the same for a student who made use of a self-generated formula for 3.1(b). No formula for the calculation of the surface area of a rectangular prism, as required in 3.1(b), had been provided on the formula sheet.

Figure 9.2 Correct use of the formula sheet (Item 1.1a)

Handwritten student work for Figure 9.2:

$$1.1 \text{ A hexagon} = \frac{3\sqrt{3}}{2} \times l^2 =$$

$$= \frac{3\sqrt{3}}{2} \times 60 \text{ mm}^2$$

$$A = 9353,074361$$

$$V = A \times h$$

$$= 9353,074361 \times 100 \text{ mm}$$

$$V = 935307,4361 \text{ hexagon}$$

Figure 9.3 Correct use of a self-generated formula (Item 3.1b)

Handwritten student work for Figure 9.3:

$$\text{Surface area} = 2(lb + bh + lh)$$

$$= 2[(10)(12) + (12)(5) + (10)(5)]$$

$$= 460 \text{ cm}^2 \checkmark$$

9.2.2.2 Categories emerging during analysis of work with correct formula use

If students achieved either partial or zero marks after applying the correct formula, the remainder of their work was examined and coded according to what they had proceeded to do.

The following three categories of errors emerged:

- substitution errors
- technical errors
- incomplete solutions

The errors are not mutually exclusive. There were examples where more than one error occurred during the students' work and each was coded.

Figure 9.4 below contains an example of a student's work containing a substitution error. The student substituted the length of one of the sides of the triangle instead of the perpendicular height as was required.

Figure 9.4 Substitution error (Item 3.3b)

[c]	$A = \frac{1}{2} b \times h$
	$= \frac{1}{2} (8) \times 6$
	$= 24 \text{ cm}$

In figure 9.5 an example of a technical error is given. In this example, the student has indicated in the formula that the radius should be squared, but when performing the calculation the value of 7.5 was not squared. This is also an example of a student's work where more than one error occurred. The formula used to calculate the volume of the cylinder is incorrect and the value substituted as the radius is incorrect, as well as the technical error in the second line.

Figure 9.5 Technical error (Item 3.4b)

V_{cylinder}	$= 2\pi r^2 h$
	$= 2\pi (7.5)(36)$
	$= 1696.46 \text{ cm}^3$

Figure 9.6 provides an example of a student's work where the solution was left incomplete. This is the student's full response to question 3.2(b). The calculation of the area of one face of the cube would be the first step in calculating the total surface area, but the student has not proceeded to multiply this by six as required to arrive at the final solution.

Figure 9.6 Incomplete solution (Item 3.2b)

$A = l \times l$
$= 8 \times 8$
$= 64 \text{ cm}^2$

9.2.2.3 Categories emerging during analysis of work with incorrect formula use

When the incorrect formula was selected, the tests were again analysed according to what formula the students were selecting. Three categories of error emerged. In the first, students selected a formula that was appropriate for the attribute they were asked to calculate, but was not correct for the shape in question. An example is given below in Figure 9.7 in which the student applied the formula used to calculate the volume of a cylinder, and not the formula to calculate the volume of a hexagonal prism, as required in question 1.1.

Figure 9.7 Formula applied for the incorrect shape (Item 1.1a)

The image shows a student's handwritten work on a grid background. The work is as follows:
Line 1: $V = \pi r^2 h$
Line 2: $= \pi (10)(100)$
Line 3: $= 31415,92654 \text{ mm}^3$

In the second, the formula was appropriate for the shape in question, but not for the attribute the students were required to calculate. Figure 9.8 provides an example of such an error in which the student applied the formula to calculate the surface area of a cylinder rather than calculating the volume of the cylindrical hole in question 1.2.

Figure 9.8 Formula applied for the incorrect attribute (Item 1.2)

The image shows a student's handwritten work on a grid background. The work is as follows:
Line 1: $V = 2\pi r (h+tr)$
Line 2: $= 2\pi \times 10 (150+10)$
Line 3: $= \underline{10053.096 \text{ mm}^3}$ with an arrow pointing to the right.

The third category indicated where students had attempted to apply a formula that was invalid. Figure 9.9 provides such an example. It represents a student's attempt to calculate the surface area of the triangular prism in question 3.3.

Figure 9.9 Application of an invalid formula (Item 3.3b)

$$\begin{aligned} A &= \frac{1}{2} (b + b) \times h \\ &= \frac{1}{2} (8 + 12) \times 6 \\ &= 60 \text{ cm} \end{aligned}$$

A further level of analysis of the second category was applied. Each of the items where the formula for the incorrect attribute was applied was examined in order to classify which formulae were selected over others. For example, Figure 9.10 shows where the formula for volume was applied instead of one for surface area in response to question 3.3(b). Figure 9.11 shows an example where the formula for surface area was applied instead of one for distance in response to question 2.2.

Figure 9.10 Volume formula applied for an item requiring surface area (3.3b)

$$\begin{aligned} A &= l \times b \times h \\ &= 12 \times 10 \times 5 \\ &= 600 \text{ cm}^3 \end{aligned}$$

Figure 9.11 Surface area formula applied for an item requiring distance (2.2)

$$\begin{aligned} \text{z.z. } A &= 2 \pi r (h + r) \\ &= 2 \pi (22,5) (180 + 22,5) \\ &= 28627,76306 \text{ m}^3 \end{aligned}$$

9.2.3 Use of SI units

The use of units emerged as an area of concern in the analysis of the four task-based interviews, and appeared as one of the outcomes assessed in the test. For this reason it also formed part of the analysis of the students' work in this task.

Several students did not indicate the unit in their answer, but for those who did, the following three categories of responses emerged:

- correct unit with correct exponent
- correct unit with incorrect exponent
- incorrect unit and incorrect exponent

There were no examples of items where students had used the incorrect unit with the correct exponent. In Figure 9.12 the solution should have the unit as cm^3 (incorrect exponent), in Figure 9.13 the solution should have the unit as cm^3 (incorrect unit) and in Figure 9.14 the solution should have the unit as m^3 (incorrect unit and incorrect exponent).

Figure 9.14 is also an example where more than one category of error is applicable. The question asked for total surface area, yet the student has applied the formula to calculate the volume of a rectangular prism.

Figure 9.12 Incorrect exponent (Item 3.1a)

$$\begin{aligned}
 A &= \cancel{l} \times b \times h \\
 &= 12\text{cm} \times 10\text{cm} \times 5 \\
 \text{Area} &= 600\text{cm}
 \end{aligned}$$

Figure 9.13 Incorrect unit (Item 3.1a)

$$\begin{aligned}
 V &= l \times b \times h \\
 &= 10 \times 12 \times 5 \\
 &= 600\text{m}^3
 \end{aligned}$$

Figure 9.14 Incorrect unit and exponent (Item 2.3)

$$\begin{aligned}
 &= l \times b \times h \\
 &= 6 \times 20 \times 11 \\
 &= 1320\text{cm}
 \end{aligned}$$

9.3 DATA PRESENTATION AND ANALYSIS

In this section, the data pertaining to student performance in the test as a whole, and in each item in particular, is presented and analysed. The overall results are first summarised and described and thereafter students' work in each item is considered. Much of the qualitative data is quantitised in this chapter in order to support the qualitative claims made.

9.3.1 Overall test results

The first step in the analysis of the students' performance in the formal written test was to summarise the overall results obtained according to the seven level rating scale (DHET, 2011) shown in Table 9.1. This is presented in Figure 9.15 below:

Figure 9.15 Result of formal written test

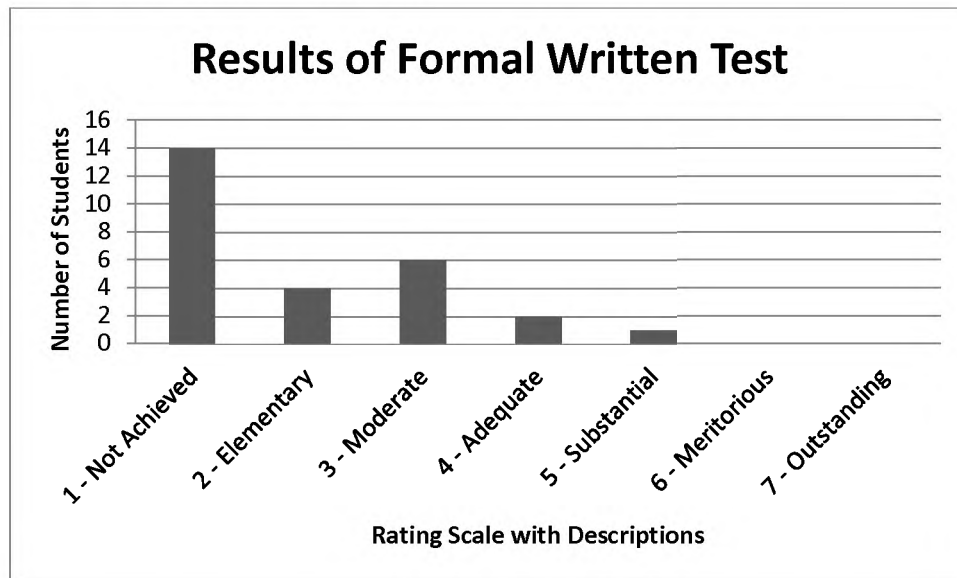

It is clear that the majority of the students in this group did not achieve the outcomes assessed in the test. 67% of the students in this group achieved scores below 40%. This suggests that Preston and Thomson's (2004) assertion that many school-going learners find measurement to be a challenging area of mathematics is also the case for these TVET college students.

9.3.2 Performance per item

After summarising the overall results for the test, each student's work was analysed per item. Of the possible 432 items (16 items x 27 students), 40 were not attempted, leaving 392 items available for this analysis. The first step to this analysis was to capture whether students achieved full marks [F], partial marks [P], zero marks [O] or had not attempted the item [X].

This summary is provided as Appendix Z. The items to which this appendix refers appear in the test paper included as Appendix Z. Appendix Z includes the coding of each item as to what measurement was required to be calculated and therefore provides a visual summary as to which types of questions were answered more successfully by the students. The students are ordered in the table from the lowest to the highest overall results and for the purpose of this discussion they will be grouped into the lower, middle or upper third of the responses analysed.

Table 9.2, an extract from Appendix Z, provides a summary of the performance for the full group of students per item type.

Table 9.2 Summary of student performance per item

	ITEM NUMBER															
	1.1(a)	1.1(b)	1.2	1.3	2.1.1	2.1.2	2.2	2.3	3.1(a)	3.1(b)	3.2(a)	3.2(b)	3.3(a)	3.3(b)	3.4(a)	3.4(b)
[F] Full Marks	11	15	7	11	7	3	0	4	17	4	10	2	0	0	7	4
[P] Partial Marks	3	2	6	1	2	1	7	2	1	7	1	11	0	1	4	7
[O] Zero Marks	13	7	13	10	16	22	12	19	7	14	12	13	23	25	12	15
[X] Left Out	0	2	1	5	2	1	8	2	2	2	4	1	4	1	4	1

Key: Measurement to be calculated

LINEAR	SURFACE AREA
AREA	VOLUME

9.3.2.1 Volume

The only items for which any students in the lower third achieved full marks were those pertaining to volume. In particular, these were items 1.1(a&b), 1.3 and 3.1(a). This pattern extends to the entire group as volume was the measurement with the highest number of students achieving full marks.

The number of students achieving full marks for items 1.1(b) and 3.1(a) is noticeably higher than for the other items requiring the calculation of volume. Both of these require the calculation of the volume of a rectangular prism, which is the prototypical example used when teaching the concept of volume. It is the first to be taught in schools, and appears first in all measurement sections of the South African mathematics curricula at all levels (see Section 2.7).

The number of students who achieved full marks for 3.2(a) drops notably and the number achieving zero marks for their attempts increases notably. This question asked students to calculate the volume of a cube, which is merely a specialised form of a rectangular prism.

However, rather than explicitly showing the length of three sides, as with 3.1(a), this example shows the length of only one side as being 8cm. The fact that the remaining sides are all equal is represented symbolically by a short line crossing each side. This requirement to interpret an additional symbolic representation would seem to have added to the challenge of this question.

A further three volume examples stand out. Items 1.2, 3.3(a) and 3.4(a) showed a much smaller number of students achieving full marks than in other volume examples. In addition, a much larger number of students achieved zero for their attempts of these questions.

In 3.3(a) students were required to calculate the volume of a triangular prism and all of the 23 students attempting the question scored zero. It required students to use the perpendicular height of the triangular surface, which was not given but needed to be calculated. Students had been taught to use the Theorem of Pythagoras to do this, however, only one student showed evidence of having recognised that this needed to be done. This student had written the Pythagorean formula on the question paper and had attempted to substitute the given measurements but had abandoned this calculation and on their answer sheet the value of the given side was used.

The remainder of the students did not show an awareness of the need to do this calculation. This echoed what was observed in interview 4 when Kaden asked whether she should “use Pythagoras” (Section 8.3.2.9) in order to calculate the height of the triangles on the resort map. She was the only student who recognised this as an alternative to physically measuring the height.

Questions 1.2 and 3.4(a) also showed a drop in students achieving full marks. Both required the calculation of the volume of a cylinder. Of the 13 students who achieved either partial or full marks for question 1.2, only 5 achieved this for question 3.4(a). This suggests some instability in students’ knowledge of how to calculate the volume of cylinders.

9.3.2.2 Area

The number of students achieving full marks for the questions asking for the calculation of area was much lower than for those requiring the calculation of volume. Similarly, the number achieving zero for their attempts was much higher.

For question 3.3(b), no student achieved full marks and only one achieved partial marks. This question required the students to calculate the total surface area of the triangular prism. Phase

2 of Task 4 similarly showed evidence of students experiencing the calculation of the area of a triangle as challenging. Seven of the ten student groups required the formula for calculating the area of a triangle to be provided [P(a)] and no student groups were able to complete this phase of Task 4 independent of mediation from the interviewer (see Section 8.3.3.3).

Students were required to calculate total surface area in questions 3.1(b), 3.2(b), 3.3(b) and 3.4(b). There were 28 students scoring partial marks all of whom submitted incomplete solutions. It was not clear whether the students scoring partial marks for these questions had an accurate conceptual understanding of total surface area as they had calculated the area of only one surface of the object.

9.3.2.3 Length

Similar to the students' performance in the questions requiring the calculation of area, there were fewer students able to achieve full marks for questions 2.1.1 and 2.2 than those able to achieve full marks for the volume questions.

Question 2.1.1 required the calculation of the length of a radius, when given the height and volume of a cylinder. This required an understanding of the relationship between the 3-dimensional attribute of volume and the attribute of length, as well as requiring the algebraic manipulation of the formula to calculate the volume of a cylinder.

It is interesting to note that in both the middle and upper third of students, more students achieved full and partial marks for this question than for question 2.2. Question 2.2 required the conceptual understanding of perimeter and the relationship between the diameter of a circle and its circumference. It does not require an understanding of the relationships between attributes in different dimensions, nor does it require the algebraic manipulation of a formula. This would suggest that students should perform comparatively better in this item.

The availability of formulae on the formula sheet may have played a role in this. The formula for question 2.1.1 was available on the given formula sheet. This allowed the students, who understood what the symbols within the formula represented, to avoid needing to use an understanding of the relationship between dimensions.

There was no formula available on the formula sheet that would assist students in the calculation of the final solution for question 2.2. Students needed to understand the concept of perimeter to arrive at the correct solution. They needed to recognise that the formula for the

circumference of a circle was required and thereafter the outside lengths of the rectangular area were to be added.

It is only in the lower third of students that performance in 2.2 is greater than that in 2.1.1. Students who achieved higher scores for the test as a whole therefore seem to be more comfortable with the technical work of manipulating algebraic formulae than they are with the conceptual understanding of perimeter.

9.3.3 The use of formulae

After student responses had been categorised according to whether they were awarded full marks, partial marks or zero marks, the use of formulae was analysed. Figure 9.1 outlined the categories that emerged from this analysis. In Figure 9.16 the results of this categorisation is provided. The responses were first classified according to whether the formula used was correct, incorrect or invalid.

Figure 9.16 Categories of responses according to use of formulae

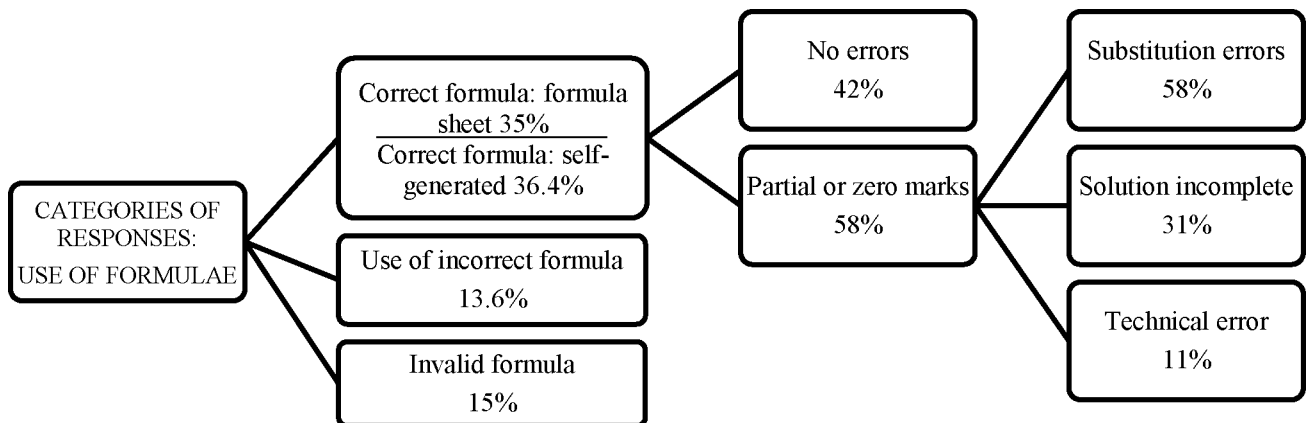

Within the responses, where the correct formulae were used, the source of these formulae was differentiated. Where the correct formula was used for the first step, the further working of the students was summarised according to whether they achieved full marks [F] or whether errors had been present and only partial marks [P] or zero marks [O] were awarded. The nature of the errors was then differentiated.

9.3.3.1 Use of the formula sheet

For the items where the correct formula had been applied in the first step, the responses were further analysed according to whether the frequency of errors was higher when formulae from the formula sheet were used or when self-generated formulae were used. Self-generated formulae were those that students had either memorised or had derived from the formula sheet.

Figure 9.17 shows this data for the full group of 27 students, as well as split into three equal groups according to the final result obtained by the student: the upper, middle and lower thirds.

Figure 9.17 Correct and incorrect responses per formula source

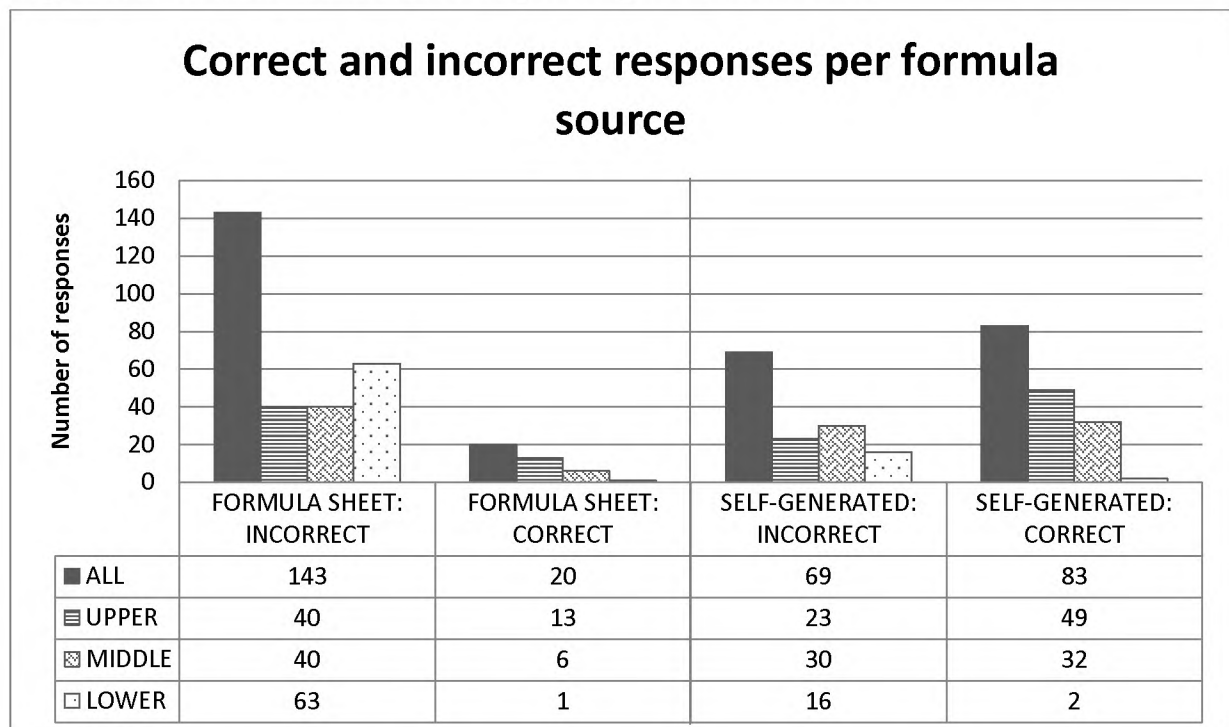

For the 163 items where students had correctly used the formula sheet, 143 (87.7%) of the final solutions were incorrect. This was as opposed to the items where a self-generated formula had been used, for which 45.4% were incorrect. The number of correct items where self-generated formulae had been used was larger for the full sample and the upper and middle groups. Only the lower third showed a larger number of incorrect answers when a correctly self-generated formula had been applied.

There were 212 examples where students had made use of the correct formula but had arrived at the incorrect solution. Of these, 143 (67.5%) were for examples where the formula sheet had been used with fewer errors occurring subsequent to the use of a self-generated formula. This observation was consistent for each third of the sample.

When examining the 103 items that were answered correctly, 83 (80.6%) showed the use of a self-generated formula. Again, this observation was consistent for each third of the sample.

The results of this analysis show that where students have generated formulae for themselves, either by memorising the formulae, or deriving it from those given on the formula sheet, they have been more successful at arriving at an accurate solution

9.3.3.2 Types of errors

As is shown in Figure 9.16, where the correct formula had been used in the calculation, 42% of the items were awarded full marks and 58% received partial or zero marks. Of those receiving partial or zero marks, the reasons for the loss of marks was differentiated. The majority (58%) were substitution errors, 31% were due to incomplete solutions and 11% due to technical errors.

Technical errors

77% of the errors classified as technical were due to students indicating that a particular value needed to be squared, but not doing so after substitution. The remaining 23% of the technical errors were items where the final answer was incorrect, but all the work, including the values substituted, was correct until that point.

Incomplete items

83% of the incomplete items occurred in responses to either 3.1(b), 3.2(b), 3.3(b) or 3.4(b). These questions required the calculation of total surface area for various objects. The responses coded as incomplete were those where students had calculated the area of one surface, but had not calculated the area of the remaining surfaces and added them together. It was not clear whether this was a conceptual error, where the student had not understood the concept of total surface area, or whether it was a matter of the student not wanting to do the remaining work in those items.

Substitution errors

The substitution errors were more conceptual than technical. After selecting the correct formula, these students then substituted incorrect measurements from those provided on the diagram or in the text.

Two of the most common calculations where these errors occurred were those involving circles and cylinders, and those involving triangles. In particular, the incorrect radius measurement was often used when working with cylinders and circles and in calculations involving triangles, the length of one side rather than its perpendicular height was frequently used.

Figure 9.17 and Figure 9.18 provide examples of each of these. In Figure 9.17, the student has substituted the length of a side of the triangular surface of the triangular prism in question 3.3, rather than its perpendicular height as required. This suggests that the relationship between length measurements of the triangle and its area is not understood.

Figure 9.18 Substitution error (Item 3.3b)

[c]	$A = \frac{1}{2} b \times h$
	$= \frac{1}{2} (8) \times 6$
	$= 24 \text{ cm}$

In the example provided below, the student has attempted to calculate the volume of the cylinder in question 3.4. The substituted value for the radius is given as 7.5cm. The radius is provided on the diagram as 15cm, but the student has halved this before substituting. This suggests a lack of understanding of the relationship between the length of a radius and the volume of a cylinder, or a lack of understanding of the difference between a diameter and radius. Students are taught that the radius is half of the length of the diameter of a circle. It is possible that the student incorrectly identified the radius as the diameter, but this, too, indicates a conceptual rather than a technical error.

Figure 9.19 Substitution error (Item 3.4a)

V_{cylinder}	$= \pi r^2 h$
	$= \pi (7.5)^2 (36)$
	$= 1696,46 \text{ cm}^3$

The example provided in Figure 9.19 is one student's attempt to calculate the volume of the rectangular block in question 1.1. The student has correctly applied the formula for the calculation of volume: *Volume = Area of base × perpendicular height*, however, as the area of the base, the student has substituted the length of the rectangular base. This suggests that the student has not understood the relationship between the length of a side and the area of a rectangular surface, or the relationship between the length of a side and the volume of a

rectangular prism. Aside from the errors in the units used in the second line, the numerical value for the height is written as 5mm rather than 50mm. This was not coded as an error, however, as the final answer showed that the student had used 50 in their calculation ($12 \times 50 = 12\,500$).

Figure 9.20 Substitution error (Item 1.1b)

$V = A_{\text{base}} \times P_{\text{height}}$
$= 250m \times 5mm$
$= 12\,500$ X

9.3.4 Attributes of shapes

Where students had made use of the incorrect formula, their work was first classified according to whether the formula selected was appropriate for the attribute to be calculated but not the shape or whether it was appropriate for the shape but not the attribute. Appendix AA contains the results of this classification.

The majority of the formulae were incorrect for the attribute to be measured rather than the shape. There were 81 examples of this error but only 11 examples where a formula for the incorrect shape had been applied. Figure 9.7 provided an example of a student's work in which they selected the formula for the incorrect shape, and Figure 9.8 an example in which a student chose to use the formula for the incorrect attribute.

A further distinction was made in order to ascertain which formulae were being selected more frequently over others. Figures 9.10 and 9.11 provided two such examples. Three broad categories emerged: the interchanging of volume, area and surface area formulae; the interchanging of length, area and surface area formulae and the interchanging of length and volume formulae.

The majority of the errors (56) concerned the interchanging of volume, area and surface area formulae. Of these, the most frequent were those in which the formulae for volume were interchanged with the formulae for surface area (25). This reveals an important conceptual error. Surface area and volume are two measurable attributes of 3-dimensional objects and students seemed to find difficulty distinguishing between the two. There were 22 examples

where students had chosen to calculate the volume rather than the surface area, and 3 in which surface area was calculated rather than volume.

Similarly, the formulae to calculate these attributes of 3-dimensional objects were interchanged with the formulae to calculate the area of a 2-dimensional surface, where this was required. There were 31 examples of this type of error: 13 showed the use of a surface area formula instead of an area formula; 15 showed the use of area formulae instead of volume, and 3 showed the use of volume formulae instead of area.

Less frequent were errors in which students interchanged the use of length, area and surface area and those in which they interchanged volume and length formulae. 12 showed the use of a length formula, such as those required to calculate the perimeter of a shape, where the surface area or area was required. 9 showed the use of a surface area or area formula where the length was required and 4 showed the use of a volume formula where the length was required. This also revealed that some students had difficulty distinguishing between measurements representing 2-dimensional and 3-dimensional attributes or did not have a stable understanding of the relationships between these attributes.

When examining the full scripts for the 27 students, 10 students showed errors that could be considered 'bi-directional'. These students had, for example, used volume formulae to calculate area in one example, as well as the reverse in another example. All of these examples involved either surface area or volume formulae. It is possible that this was evidence of instability in their conceptual understanding of these attributes, or that it reflected a symbolic error in which the incorrect word had been taken as the naming word for a particular attribute.

In addition to these 10 students, a further 12 students had used an incorrect formula when calculating a particular attribute more than once. For example, a student may have used a volume formula instead of a surface area formula, and later a length formula instead of surface area formula. Again, surface area and volume were involved in all 12 of these examples.

9.3.5 Use of SI units

Lastly, the students' use of units was examined. The accurate use of SI units was listed as an outcome being assessed in this test and the use of units appeared as an area of concern during the task-based interviews.

17% of the students' responses did not indicate a unit, but 83% could be analysed according to how students were using the units and what errors may be present. 57.1% of these examples were correctly reported, with the correct unit indicated, and the correct exponent used. In 35.3% the unit was correct but the exponent incorrect, for example, a volume measurement may have been reported as cm^2 rather than cm^3 . There were not many examples in which both the unit and exponent were incorrect (7.6%) and no examples where the exponent was correct but the unit itself incorrect.

Figure 9.21 Use of units when reporting solutions

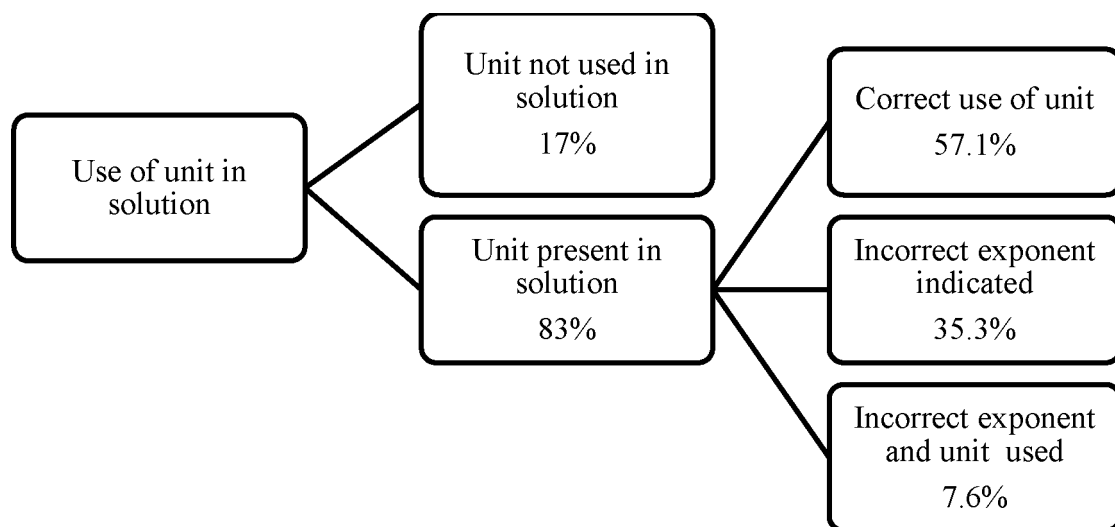

It is interesting to note that the use of units in this task was more accurate than when used in the embodied task-based interviews

9.3.6 Summary

The analysis of the test item responses from the students has revealed a detailed pattern of where errors are occurring and point to particular measurement conceptualisations that may be leading to these. It has also allowed a view of the students as they complete these tasks from which we can infer what stable and emerging measurement conceptualisations are present.

9.4 STABLE AND EMERGING CONCEPTUALISATIONS

The following sections provide an overview of the stable and emerging conceptualisations that were observed on analysing the students' test scripts, as well as outlining some additional insights.

9.4.1 Stable conceptualisations

On analysing the students' work it was possible to see that, despite the results being so poor, there were stable conceptualisations that could be seen in their working. One of these was a general ability to manipulate algebraic expressions accurately in order to solve basic equations. While the values the students had substituted were frequently incorrect, the symbolic algebraic work was well done.

Calculation of rectangular and circular areas, as well as the volume of rectangular prisms and cubes, was also generally accurate.

9.4.2 Emerging conceptualisations

Students frequently applied the incorrect formula to a problem, revealing an unstable conceptualisation of the attributes to be calculated, and of the properties of the various shapes. In particular, surface area and volume appear to be measurements that are commonly confused. This is important to note, as these are two different attributes of 3-dimensional objects, but are measurements that represent different dimensions themselves. The fact that this is reflected in interview 2, in which the majority of the students measured total surface area rather than the volume of the cube, further supports this observation.

9.4.3 Additional insights

The students' use of the formula sheet was particularly interesting. The document is provided as a resource to students and yet its use seemed to not be beneficial. More solutions were incorrect when the formula sheet had been used than correct, whereas for students who had derived a formula for themselves the likelihood of their response being correct was larger. This raises the question of whether this is a useful resource to provide, and what the reasons might be for these students to have struggled to optimally use it.

9.5 SUMMARY

Task 5 took the form of a document analysis, therefore limited insight regarding the individual's measurement conceptualisation was possible. However, it was possible to extract a large amount of detail from the analysis of these tests that has allowed insight into the group of students as a whole.

CHAPTER 10

DISCUSSION AND CONCLUSION

10.1 INTRODUCTION

This chapter will present a discussion of the findings of this research as structured by the research questions. Each research question was briefly considered after presentation and analysis of the data pertaining to each task. What is discussed in this chapter is how these results can be brought together to provide a final response to these questions. This is done both in relation to the data and to the literature that guided the development of this research project.

Questions 1 and 2 require a technical response related closely to task performance and how this relates to theory defining measurement proficiency for the specific measurement domain as well as the development of mathematical thinking (Tall, 2013b).

Question 3 requires the synthesis of the findings in relation to Questions 1 and 2, as well as careful consideration regarding how students used their prior knowledge and how they responded to mediation as evident in their engagement in the measurement tasks presented to them. Considered together, these observations and findings have allowed a view as to where the break between what students need to possess as stable conceptualisations, but rather possess as emerging conceptualisations, might occur.

This chapter includes a discussion of the strengths and limitations of the study, as well as an outline of the implications of the findings. Lastly, avenues for further research are established before a reflection on the process of the research.

10.2 AN OVERVIEW OF THE INSIGHTS FROM TASKS 1 TO 5

Students completed up to five tasks as they participated in this research. As this research is exploratory, these tasks were varied in their design in an attempt to capture as many facets of the students' measurement conceptualisations as possible. Students' engagement in each measurement task allowed insight into the stable and emerging measurement conceptualisations held by each student.

In the following sections, each task will be considered for the insight they provided into these students' existing measurement conceptualisations. (This discussion relates to, and expands on,

Sections 6.5, 7.5, 8.4 and 9.4). Where conceptualisations are referred to as ‘unstable’, the fact that they are emerging is implied. Students worked with the conceptualisation in some form during the task, however, in those cases they were not able to do so with complete accuracy.

Following immediately after this discussion are the answers formulated for Research Questions 1 and 2

10.2.1 Tasks 1 and 2

The first two tasks were decontextualised and modelled on classic measurement tasks that were true to the conceptual essence of the measurement of area (e.g. Barrett et al, 2011; Feikes, Schwingendorf & Greg, 2009) and volume (e.g. Ben-Haim, Lappam & Houang, 1985; Voulgaris & Evangelidou, 2004). The tasks required students to physically measure the objects, but without the use of standard measuring instruments. This forced an engagement with the concepts of area and volume by disallowing a direct reliance on any procedural knowledge.

10.2.1.1 Task 1: Area measurement

There were a variety of strategies used by the students to begin to measure the area of the surface provided, but what they had in common was a demonstration of an understanding that measuring area involves iterating a unit until a surface is completely covered (Cavanagh, 2008). This could be defined therefore as stable.

Where the strategies differed was in their level of sophistication and efficiency. A number of students iterated the unit tile around the inside perimeter, leaving large gaps that they attempted to account for later. If Sarama and Clements’ (2009) progression is used for comparison, this type of strategy would be classified as “primitive covering” (p. 302). Similarly, many students used strategies that could be classified “area unit relater and repeater” (p. 302) and “partial row structurer” (p. 302) (see Section 3.4.6.1), all of which are several levels below “array structurer” (p. 304), which would be expected of someone who had worked with formulae to calculate measurements previously. This would have been the case for these students as they had all attended basic schooling. Those who structured arrays recognised the need to do so quickly, while most of those who used the more labour-intensive strategies named above took some time to arrive at a decision about how to proceed. This reveals a possible instability in the link between the pure embodied understanding of area and how to obtain a measure of it. Another observation was that, regardless of the relative sophistication of the coverage strategy,

the majority of students counted in 1s rather than applying multiplicative reasoning when calculating the number of whole tiles.

In the second phase of this task, students were required to find a way to incorporate the areas that could not be covered with whole unit tiles. Most students elected to combine the partial areas by sight to form whole units, and to add these to the total area. This was done extremely well, and was the most successful of the strategies. Their ability to make a quick judgment about the magnitude of the area relative to the unit (Gooya et al., 2011) suggests a stable conceptualisation of estimation for these students.

Several students opted to label the remaining areas with rational numbers expressed in fraction notation and attempted to add these. Every student who chose this strategy revealed an unstable conceptualisation of rational numbers. Whole number bias, which is a common conceptual error (Torbeys et al., 2015), was found in each of their workings. Students were particularly responsive to mediation on this point, which indicates that the emergence of an accurate and stable conceptualisation of rational numbers is occurring.

10.2.1.2 Task 2: Volume measurement

Many students revealed a stable misconception that volume is equivalent to surface area as an attribute of an object. This was sufficiently stable to require the construction of the whole block used in the task with unit cubes and counting those cubes in 1s to convince the student that volume is distinct from the surface area measurement they had taken. This is a clear example of a met-before (Tall, 2013a) that has become problematic as it is preventing the construction of an accurate and stable conceptualisation of volume.

Even for those students who did not hold onto this stable misconception, volume was a challenge to measure without being able to use a formula. When asked to define ‘volume’, most defined it by the formula for calculating the volume of a rectangular prism and were unclear on what the quantity refers to. Some gestured vaguely in the air to indicate an object with three dimensions, but many were unable to begin to respond to this question. This severe instability with regard to the concept of volume is interesting when considered with the fact that these students will have worked with volume in the context of their prior formal schooling.

A possible explanation can be found in Outhred and Mitchelmore’s (2000) claim that “student difficulties in volume measurement have... been linked to an early emphasis on formulae” (p.

145). This is the most likely explanation considering that most of the students' immediate responses were to define volume as *length* × *breadth* × *height*.

10.2.2 Task 3

Task 3 took the form of an experiment involving the measurement of flow rate. Flow rate was a new concept for these students, and in addition, it represented a complex measurement rather than the measurement of basic spatial object attributes.

The experiment consisted of four substantial subtasks and therefore the student was engaged in this activity for much longer than Tasks 1 and 2. Mediation remained solely at the level of signs, but the nature of the task was more interactive and the student was required to verbally interact with the interviewer at certain points to make predictions and provide justification for them.

While the concept of flow rate was still emerging, during the course of the interview it became evident that the concept of speed was sufficiently stable to allow the understanding of speed as a rate to be supportive of their acquisition of the concept of flow rate. As was shown, students initially used terms related to speed to describe the flow rate while they were becoming more familiar with the quantity. As much as 'rate' is an abstract construct (Thompson & Thompson, 1994), speed is a quantity about which even young children have a form of understanding (Thompson, 1994). The comparative relationship between fast and slow, as an everyday concept, is constructed through physical experience of motion at a young age. That it was so immediately supportive of the beginning of the construction of a new measurement conceptualisation for these students was enlightening.

A further conceptualisation that was revealed to be stable, and also supportive of the development of the concept of flow rate during this task, was the understanding of the influence of pressure on flow rate. Students demonstrated, through gestures and verbalised observations, that they recognised pressure as a factor influencing the flow rate in the experiment and that they understood the influence that a change in pressure would have on the system.

As the task progressed, there was evidence of the emergence of conceptualisations specific to flow rate. Students became more accurate in their predictions of flow rate by appropriately applying proportional reasoning, and when asked to describe why the flow rate changed in different subtasks, they were increasingly able to identify the influencing factor.

10.2.3 Task 4

Task 4 represented the most complex of the practical tasks. There were five phases to this task. It required the measurement of length dimensions in order to calculate the areas of shapes representing buildings on a map. Students were then required to use a scale to obtain the true area measurements and calculate the cost of building the holiday resort represented on the map.

Students were provided with two rulers, paper, pencils, erasers and a basic calculator and were permitted to work with a peer for this task. This change in the interview situation allowed another perspective of the student as they engaged in measurement activity.

All but one of the pairs of students were able to work with the rectangular shape without hesitation. They recalled the formula required to calculate the area, measured the correct dimensions and quickly arrived at an accurate solution. Rectangular area measurement calculation is therefore a stable concept for these students.

Where they experienced challenges was with the other shapes, which included a circle, a hexagon comprising 6 triangles and a composite rectangle. Many required the formulae to be provided to them, but remained uncertain about what linear measurement was required in order to use the formula appropriately. Therefore, while for rectangular measurement students were able to act almost instantaneously, their conceptualisation of the area measurement and calculation for other shapes was not yet stable.

The application of the use of the scale was found to be challenging. Students were able to use it when converting lengths, however, if they had calculated the area in cm^2 and needed to convert to m^2 all required mediation. There was also further evidence of students struggling to know which units applied to which answers.

10.2.4 Task 5

Task 5 represented a 'static' assessment of measurement knowledge, and was conducted subsequent to the Mathematics lectures in measurement.

This written assessment required symbolic formal work in calculating measurements, in the absence of the objects to which the measurements referred, and for a number of items, in the absence of a diagram depicting the object. The students' performance on this assessment

revealed substantial instability in their ability to apply formulae to the appropriate shape or for the measurement of the appropriate attribute of the object.

Students were able to perform the algebraic manipulations required to solve an equation, but were more frequently than not substituting the incorrect dimensions and therefore obtaining an incorrect solution.

Despite difficulties, students were best able to calculate the area of rectangles and circles (also evident in Task 4) and the volume of cubes and rectangular prisms.

Regarding the students' use of units, there was evidence of relative stability. More than half of the items analysed included the correct unit, with the correct exponent.

10.3 STABILITY AND EMERGENCE AS EVIDENT IN STUDENTS' ENGAGEMENT IN THE MEASUREMENT TASKS

It is not as simple a task as creating a list in order to respond to Research Questions 1 and 2. There are subtleties that differentiate those items that should appear on such a list, and these need to be reflected in the response. Research Questions 1 and 2 are therefore provided their technical answers by Table 10.1. This table provides a summary of the basic stable and emerging measurement conceptualisations observed in this research, but further distinguishes between those aspects that are either conceptual/embodied in nature, or procedural/symbolic.

The actions of the students as they worked allowed further insight into the way in which this stable and emerging knowledge influenced their task performance. The knowledge that they possess, whether it be stable or emerging, takes the form of discrete strands. This limited their ability to optimally engage in the measurement activities because their measurement conceptualisations had not formed a rich network of relationships that allows full conceptual thinking. This notion is expanded upon in Section 10.3.2.

10.3.1 Research Questions 1 and 2

It was noted in Section 3.4.5 that the distinction between procedural and conceptual knowledge is useful in working with measurement. Procedural is understood here to comprise “the formal language, or symbol representation system, of mathematics [and] the algorithms, or rules, for completing mathematical tasks” (Hiebert & Lefevre, 1986, p. 6). Conceptual knowledge is defined as that which is rich in relationships..., a connected web of knowledge... in which the

linking relationships are as prominent as the discrete pieces of information” (p. 4). As measurement is an activity that takes place in the real world, its conceptual form is an embodied one.

In order to answer Research Questions 1 and 2, stable and emerging conceptualisations have been further divided into those that are conceptual/embodied and those that are procedural/symbolic. Research Questions 1 and 2 are answered below:

Table 10.1 Stable and emerging conceptual/embodied and procedural/symbolic knowledge

	Conceptual/Embodied	Procedural/Symbolic
Stable	<p>Conceptual understanding of area (coverage with no gaps or overlaps)</p> <p>Everyday conceptual understanding of speed</p> <p>Everyday concept of the influence of pressure on flow rate</p>	<p>Coverage (by using a number of different strategies) of surface with units</p> <p><i>Measurement of volume requires determination of number of cubic units that could cover the surface [misconception problematically stable for many]</i></p> <p>Use of ‘familiar’ artefacts, e.g. ruler, linear scale, calculator, formulae (technical sense)</p> <p>Algebraic manipulation of formulae</p> <p>Procedures (area): rectangles; circles</p> <p>Procedures (volume): cube; rectangular prism</p> <p>Application of units in purely symbolic tasks [no conversion needed; Task 5]</p> <p>Estimation relative to a square unit</p>
Emerging	<p>Fractional units used in coverage of a surface</p> <p>Defining volume, including differentiating it from other</p>	<p>Use of fractions (notation, addition)</p> <p>Accurate use of terminology when discussing flow rate</p>

	<p>properties of 3-dimensional objects (e.g. total surface area; weight)</p> <p>Linking of measurements from artefacts to underlying concept</p> <p>Substitution of correct measurement into formula</p> <p>Fractional units used in coverage of a surface</p>	<p>Use of multiplicative reasoning in measurement of area using non-standard units (most counted in 1s)</p> <p>Applying proportional reasoning when predicting results from composite measurement [development evident as Task 3 progressed]</p> <p>Correctly inferring influencing factor after observing a dynamic system [developed a lot during the task]</p> <p>Use of units</p> <p>Use of scale to convert</p> <p>Recall of formulae</p> <p>Selection of the correct formula for the property being calculated</p> <p>Problem solving and collaboration</p> <p>Units in embodied tasks [required a fully blended embodied/symbolic understanding of units in measurement]</p> <p>Use of fractions as representation for measurement (notation, addition)</p> <p>Procedures: triangles (area); triangular prisms (volume)</p>
--	--	--

10.3.2 Discrete strands of knowledge and the broken link

As the students engaged in the measurement tasks, and their measurement conceptualisations began to emerge, it was also noticed that the presence of a seemingly stable conceptualisation did not always translate into optimal or successful engagement in the task. For example, students who held a stable conceptualisation of area were not necessarily able to calculate the area of a triangle; students who had a stable notion of how to calculate the area of a circle could not do so in the written test; or certain students who were able to use units correctly, and

reliably, in the written test but were unable to do so in Task 4. This was repeatedly observed, and on analysing the components of the tasks and the answers to the first two Research Questions it became clear that a further description can be applied to these conceptualisations: that they represent discrete strands of knowledge for these students.

The ability to apply the procedure for calculating the area of a rectangle or to add fractions or convert units did not mean that this knowledge could be applied in the measurement task. These strands of knowledge existed for many, but were disconnected.

Measurement activity requires, as was indicated by Tall (2013b), a blend of symbolism and embodiment, and similarly a blend of conceptual and procedural knowledge (Lamon, 2008). These forms of knowledge need to interact in order to successfully complete measurement tasks. What has been observed is that there is a break in the links between these in the embodied subject. The students displayed an ability to work symbolically, most notable in their ability to manipulate algebraic expressions, but were unable to apply that to the embodied world of measurement when required to solve equations to calculate a measurement. The reverse was also true. Where there was a stable conceptual/embodied understanding of surface area, students did not apply this when asked to calculate surface area in the written test. This model is provided in Figure 10.1.

Figure 10.1 Broken links between the conceptual/embodied and procedural/symbolic

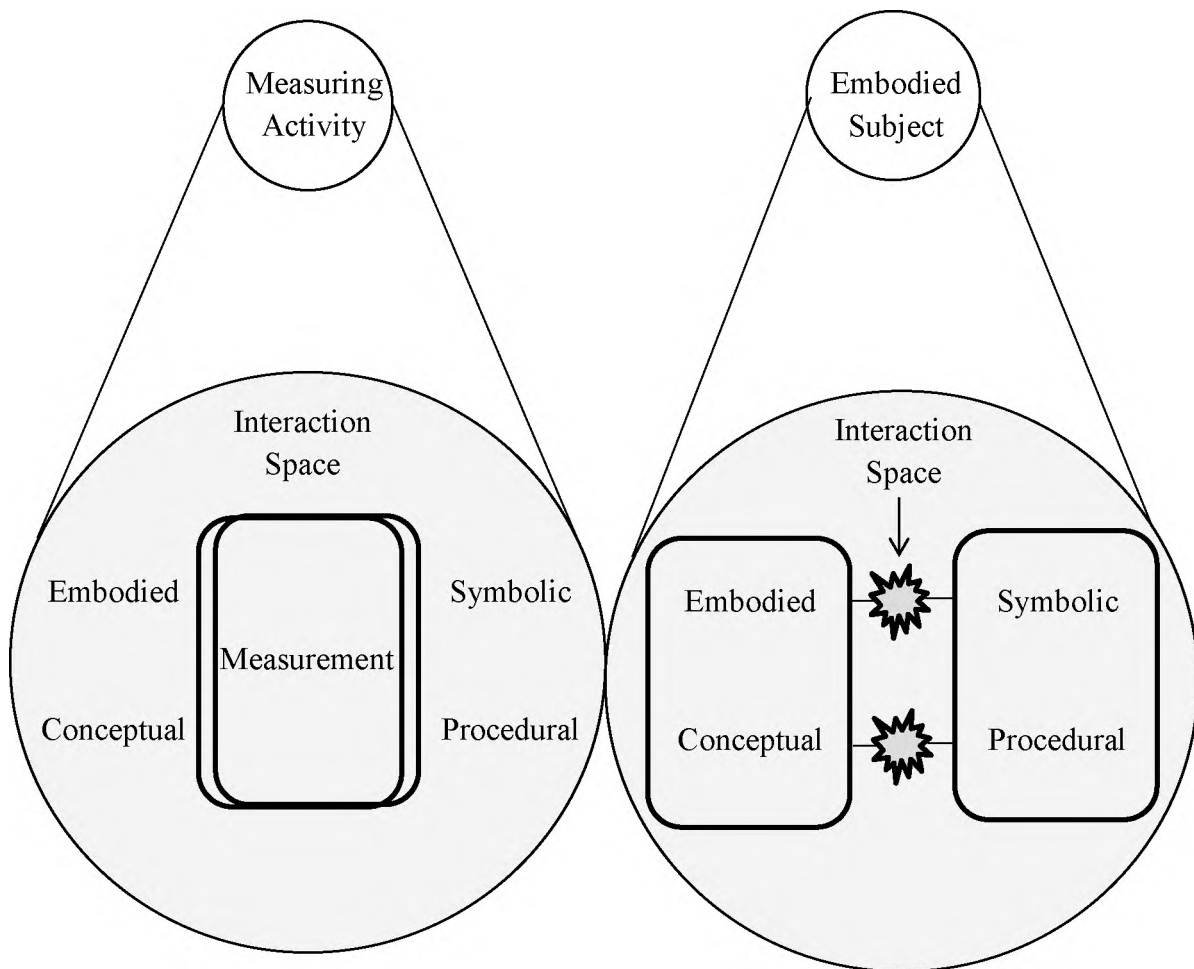

Engineers need to be able to function effectively at the symbolic formal level of thought, however, the nature of their work, particularly with regard to measurement, requires this symbolic formal work to have a strong link to the embodied world. What the students displayed in this research was that they possess some of the conceptual embodied knowledge, and some of the symbolic formal knowledge, at varying levels of stability, but struggle to bring them together effectively. This, then, is the necessary aim for teaching and learning of measurement for these students, and leads to the necessity of asking the third Research Question regarding where this break between stability and emergence might occur.

10.4 FACILITATING THE CONSTRUCTION OF STABLE AND ACCURATE MEASUREMENT CONCEPTUALISATIONS

Through reflecting on the students' engagement in the task-based interviews, as well as the written test, it is possible to put forward a set of suggestions regarding how to better facilitate

students' construction of accurate and stable measurement conceptualisations. In order to provide a response to the third Research Question, Tall's (2013a) model of the development of mathematical thinking needs to be reconsidered, with reference to how it can help us to understand the broken link referred to in Section 10.3.2. Thereafter, Tasks 3 and 4 will be discussed in light of the conceptual development that revealed itself as the tasks progressed.

10.4.1 Tall and the broken link

Tall's (2013a) theory of development can assist in explaining the source of the broken link shown in Figure 10.1. If Tall's (2013a) model of development is reconsidered, the first moment in which this break occurs can be traced. Tall (2013a) theorised that mathematical thinking, in relation to measurement proceeds in a diagonal direction from the embodied to the symbolic formal world. This is depicted below (Tall, 2013a, p. 2):

Figure 10.2 Tall's developmental model

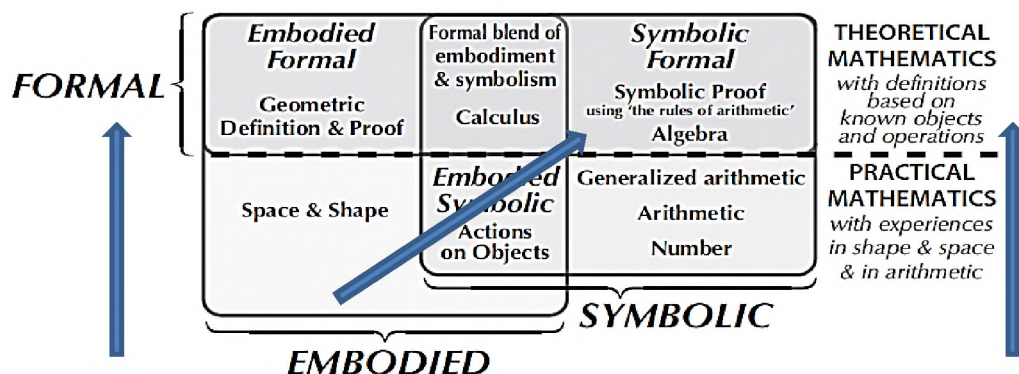

This is mirrored in the South African curriculum, where learners initially work exclusively with physical measuring tasks, and their work becomes increasingly symbolic and formal. In many subjects, the link to the embodied world is lost as the curriculum moves to focus exclusively on formal symbolic work. Tall's (2013a) notion that development is a progression, and movement is *from* embodied *to* symbolic formal implies that the embodied world is 'left behind' once symbolic formal thought is achieved. This is evident, too, in his model, in the lack of overlap of the embodied with the symbolic formal.

The measurement learning trajectory, according to South African curricula, when considered with Tall's model, reveals the precise moment in the curriculum when the embodied world begins to blend with the symbolic. In Grade 5, learners gradually begin to encounter the use of formulae to calculate measurements. By Grade 6 they are completing much of their

measurement work with formulae, and the use of physical measurements in the embodied world begins to decline (see Section 2.7).

Figure 10.3 The measurement learning trajectory in South African school curricula

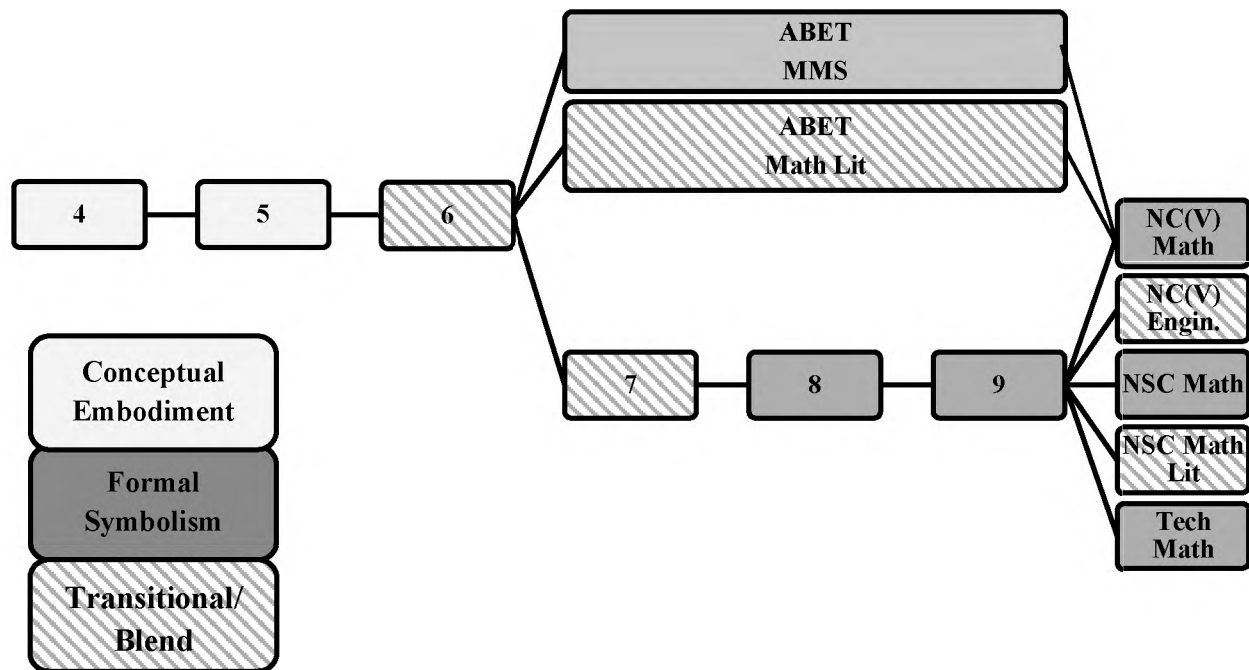

If the broken link shown in Figure 10.1 is to be effectively mended for these adult students, one would need to provide opportunities to engage in measurement activities in the manner in which these are approached when first encountered at school. This does not mean to say that adult students should be working from Grade 6 children’s texts, nor that they need spend excessive time working at that level. What it does mean is that activities should be carefully structured such that they allow the student to develop in their abstract conceptualisation of the concept while maintaining an embodied understanding of this concept as should be happening at Grade 6 level in the schooling system. This need not only be applied to the measurements that appear in the Grade 6 curriculum. It is the approach that is of value.

The failure of the current approach in NC(V) Mathematics classrooms, where measurement is taught as the application of formulae to 2-dimensional representations of objects, is evident in these students’ test results. Berger (2005) highlights that even in her university mathematics classroom, where students are learning axiomatic formal mathematics, it is essential to allow the students an opportunity to work with new concepts at the heap, complex and potential concept (Vygotsky, 1926/1986) levels if these concepts are to become fully known. It is not

possible to provide formal instruction in thinking in concepts. Therein lies the value in taking an approach that returns the student to working with both the embodied/conceptual world while developing the symbolic formal thought, and ensuring that the embodied world is not left behind as more sophisticated thought becomes possible.

10.4.2 Tasks 3 and 4 and the development of measurement conceptualisations

Tasks 3 and 4, while aiming at uncovering students' measurement conceptualisations, resulted in evidence of these students' conceptual development as they worked on the tasks.

As explored in 10.4.1, it is necessary to maintain a link between the symbolic and the embodied worlds when working with measurement concepts and these two tasks achieved that. Task 3 provided a physical experience of flow rate during the practical experiment, and Task 4 involved the students in a measurement task that could realistically be encountered in the real world. While working strongly in the embodied world, however, symbolic work was also required in both. In Task 3, students were introduced to the method of calculating flow rate and were then required to do so themselves. In Task 4, students needed to apply formulae to calculate the areas required and complete the task.

In addition, these two tasks allowed for more interaction than Tasks 1 and 2. In Task 3 the student interacted continuously with the interviewer as they made predictions and explained their reasoning. As a result, the conceptual accuracy with which they were able to describe the experiment increased and showed evidence of development in their conceptualisation of this new concept. In Task 4 the student collaborated with a peer, and through working in this way each partner was able to learn from the other, and the pairs showed improved performance as the task proceeded.

Another feature of these tasks was the level of their complexity. They each had substantial subtasks and phases. With the observation made that the students' existing measurement conceptualisations frequently comprised discrete strands that were not integrated and were therefore ineffective in enabling the student to solve measurement tasks, this complexity is valuable. Instead of facilitating the creation of a weak link to replace the broken one, a complex task requires the integration of knowledge, which creates a stronger link between the strands, as well as between the conceptual/embodied and the procedural/symbolic. This is illustrated in the figure below:

Figure 10.4 The integration of knowledge strands during complex activity

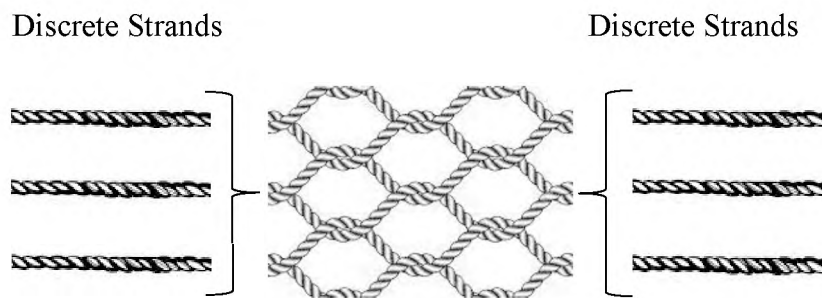

Importantly, Tasks 3 and 4 provide examples of how work can be structured at the level argued for in 10.4.1 without resorting to using the same types of tasks you would with a 12-year old. They successfully held in tension the embodied and symbolic world and in the case of Task 3, resulted in real learning in a complex domain of measurement that is not the spatial measurement of object attributes.

10.5 STRENGTHS AND CONTRIBUTIONS OF THE RESEARCH

The primary strength of this research lies in the fine-grained detail of the account of the students' engagement in the measurement tasks. It has permitted insight into the structure of these adults' measurement conceptualisations and in so doing contributes towards filling several gaps simultaneously.

This detailed account provides a contribution towards the understanding of adult mathematical thought, particularly with regard to measurement. Research on measurement learning is a relatively small field in mathematics education and within that field, adult learning of mathematics for the workplace is largely overshadowed by research addressing the needs of primary school learners.

In addition to contributing to measurement research by focusing on the adult, this research has included a focus on flow rate. The majority of the existing research focuses on measurement of spatial attributes of objects, however, engineers are required to work with more complex quantities, of which flow rate is one. A focus on the beginner's conceptualisation of that concept is original.

The findings themselves provide important contributions to the field. The identification of the broken link between the embodied and symbolic aspects of the measurement concepts in the

students' work represents an original insight into the act of measuring. In addition, the identification of the precise moment in South African schooling where this link would have started to weaken for these students is an insight not yet gained and holds promise for the design of programmes that may assist students who are struggling in the same way.

The deep insight that was gained into the prior knowledge, or existing conceptual knowledge, of measurement, particularly for the ten learners who participated in all five tasks, must also be considered an important contribution. The depth and detail in the descriptions of their conceptualisations of measurement and engagement in the tasks is substantial. While it cannot be generalised to other individuals it represents a significant contribution towards a more comprehensive understanding of how adults engage in measurement activities and how they employ both stable and emerging conceptualisations to do so.

10.6 LIMITATIONS

When research is exploratory, as is the case here, the aim is not to uncover definitive answers to research questions, but rather to open further avenues for exploration. This study has been successful in raising further questions, but cannot claim to have uncovered any solution to the challenges faced by students in learning measurement.

A further limitation is that the small scale of this research does not allow for the results to generalise to other contexts, and the subjective nature of the mediation decisions in the interview situation similarly prevent generalisability. However, these two limitations can be viewed as strengths if considering that the goal of the research was to explore, in as much depth as possible, the students' conceptualisations. This required intense work with a necessarily small group of students, and the immersion of the researcher in the process of assessment. It limits generalisability, but is the reason for the achievement of that goal.

10.7 IMPLICATIONS OF THE STUDY

The findings of the study, although not generalisable, have revealed issues that hold implications for curriculum design. The current approach to teaching measurement in NC(V) Mathematics is not facilitating the students' construction of conceptualisations that are accurate and stable, and are sufficiently linked to the embodied world so as to allow for the development of adaptive measurement expertise.

The broken link identified in the findings is entrenched when strategies are used that emphasise formal symbolic calculations over maintaining the link between the measure and its embodied meaning, as is the case in the NC(V) Level 2 Mathematics curriculum (DHET, 2011). For engineers who need to perform complex measurements in the workplace, this leaves a gap in their knowledge and conceptualisation of measurement.

10.8 AVENUES FOR FURTHER RESEARCH

Due to the exploratory nature of this research, several avenues have been highlighted for which research is required.

Most urgent are questions around the broken link identified. Research is required to answer questions about how this break occurs, how to prevent it, and how to assist a student who is experiencing it. Further research is also required to investigate whether this broken link is a generalisable problem.

10.9 REFLECTION

Having taught in a TVET college, I have witnessed many students grow disheartened as they struggle with Mathematics. I have experienced the frustration, as an educator, of not knowing how to assist these students. What I have always believed is that TVET students arrive with a wealth of knowledge that could be a resource to the educator who understood the structure of it. The detailed and nuanced view of this knowledge that was gained from engaging with the students in this research was rewarding in itself. The next step, that I am looking forward to taking, will be to explore further how the lessons learned through this project might find themselves enacted in the classroom, to the benefit of TVET Mathematics students.

References

- Andersson, B. & Nilsson, S. (1964). Studies in the reliability and validity of the critical incident technique. *Journal of Applied Psychology*, 48(6), 398-403.
- Babai, R., Nattiv, L., & Stavy, R. (2016). Comparison of perimeters: improving students' performance by increasing the salience of the relevant variable. *The International Journal of Mathematics Education ZDM*, 48(3), 1-12.
- Bakker, A., Wijers, M., Jonker, V. & Akkerman, S. (2011). The use, nature and purposes of measurement in intermediate-level occupations. *The International Journal of Mathematics Education ZDM*, 43(5), 737-746.
- Basson, I. (2002). Physics and mathematics as interrelated fields of thought development using acceleration as an example. *International Journal of Mathematical Education in Science and Technology*, 33(5), 679-690.
- Barrett, J. E., Clements, D. H., Klanderma, D., Pennisi, S. J., & Polaki, M. V. (2006). Students' coordination of geometric reasoning and measuring strategies on a fixed perimeter task: Developing mathematical understanding of linear measurement. *Journal for Research in Mathematics Education*, 187-221.
- Barrett, J.E., Cullen, C., Sarama, J., Clements, D.H., Klanderma, D., Miller, A.L. & Rumsey, C. (2011). Children's unit concepts in measurement: a teaching experiment spanning grades 2 through 5. *The International Journal of Mathematics Education ZDM*, 43(5), 637-650.
- Battista, M. T., Clements, D. H., Arnoff, J., Battista, K., & Borrow, C. V. A. (1998). Students' spatial structuring of 2D arrays of squares. *Journal for Research in Mathematics Education*, 503-532.
- Baturo, A. & Nason, R. (1996). Student teachers' subject matter knowledge within the domain of area measurement. *Educational Studies in Mathematics*, 31(3), 235 – 268.
- Beck, P.S., Eames, C., Cullen, C., Barrett, J., Clements, D. & Sarama, J. (2014). Linking children's knowledge of length measurement to their use of double number lines. In P. Liljedahl, C. Nicol, S. Oesterle & D. Allan (Eds.), *Proceedings of the 38th Conference of the International Group for the Psychology of Mathematics Education and the 36th Conference of the North American Chapter of the Psychology of Mathematics Education* (Vol. 2) (pp. 105-112). Vancouver, Canada: International Group for the Psychology of Mathematics Education.
- Ben-Haim, D., Lappan, G., & Houang, R.T. (1985). Visualising rectangular solids made of small cubes: Analysing and effecting students' performance. *Educational Studies in Mathematics*, 16(4), 389-409.
- Berger, M. (2005). Vygotsky's theory of concept formation and mathematics education. In H.L. Chick & J.L. Vincent (Eds.), *Proceedings of the 29th conference of the International Group for the Psychology of Mathematics Education* (pp. 153-160). Melbourne, Australia: The International Group for the Psychology of Mathematics Education.

- Berger, M. (2006). Making mathematical meaning: From preconcepts to pseudoconcepts to concepts. *Pythagoras*, 63, 14-21.
- Beswick, K., Muir, T. & Wells, J. (Eds.). (2015). *Proceedings of the 39th Conference of the International Group for the Psychology of Mathematics Education*. Hobart, Tasmania: International Group for the Psychology of Mathematics Education.
- Bhattacharya, H. (2008). Interpretive research. In L.M. Given (Ed.), *The SAGE Encyclopaedia of Qualitative Research Methods* (pp. 464-467). London: SAGE Publications Ltd.
- Blatter, J.K. (2007). Case Study. In L.M. Given (Ed.), *The SAGE Encyclopaedia of Qualitative Research Methods* (pp. 68-71). London: SAGE Publications Ltd.
- Butterfield, L.D., Borgen, W.D., Amundson, N.E. & Maglio, A.T. (2005). Fifty years of the critical incident technique: 1954-2004 and beyond. *Qualitative Research*, 5(4), 475-497.
- Carrejo, D.J. & Marshall, J. (2007). What is mathematical modelling? Exploring prospective teachers' use of experiments to connect mathematics to the study of motion. *Mathematics Education Research Journal*, 19(1), 45-76.
- Carpenter, T. P. (1975). Measurement concepts of first-and second-grade students. *Journal for research in Mathematics Education*, 3-13.
- Carpenter, T. P. & Lewis, R. (1976). The development of the concept of a standard unit of measure in young children. *Journal for research in Mathematics Education*, 53-58.
- Cavanagh, M. (2008). Area measurement in year 7. *Reflections on measurement and geometry*, 33(1), 55-58.
- Chang, K. L., Males, L. M., Mosier, A., & Gonulates, F. (2011). Exploring US textbooks' treatment of the estimation of linear measurements. *The International Journal of Mathematics Education ZDM*, 43(5), 697-708.
- Cho, S.J. (Ed.) (2015). *The Proceedings of the 12th International Congress on Mathematics Education: Intellectual and Attitudinal Changes*. New York: Springer.
- Clement, J. (2000). Analysis of clinical interviews: Foundations and model viability. In A.E. Kelly, R.A. Lesh (Eds.), *Handbook of Design in Mathematics and Science Education* (pp. 547-589). London: Lawrence Erlbaum Associates.
- Clements, D.H., Battista, M.T., Sarama, J. & Swaminathan, S. (1996). Development of turn and turn measurement concepts in a computer-based instructional unit. *Educational Studies in Mathematics*, 30(43), 313-337.
- Clements, D. H., Battista, M. T., Sarama, J., Swaminathan, S., & McMillen, S. (1997). Students' development of length concepts in a Logo-based unit on geometric paths. *Journal for Research in Mathematics Education*, 70-95.
- Clements, D. H., & Burns, B. A. (2000). Students' development of strategies for turn and angle measure. *Educational Studies in Mathematics*, 41(1), 31-45.
- Cohen, L., Manion, L. & Morrison, K. (2011). *Research Methods in Education* (7th ed.). Oxon: Routledge.

- Collingridge, L. (2013). Schools quintile system to change? *Corruption Watch*. Retrieved July 1, 2016 from <http://www.corruptionwatch.org.za/schools-quintile-system-to-change/>.
- Cortina, J.L. & Visnovska, J. (2016). Reciprocal relations of relative size in the instructional context of fractions as measures. In C. Csíkos, A. Rausch, & J. Sztányi (Eds.), *Proceedings of the 40th Conference of the International Group for the Psychology of Mathematics Education* (Vol. 2) (pp. 197-186). Szeged, Hungary: International Group for the Psychology of Mathematics Education.
- Cosser, M., Kraak, A. & Winnaar, L. (2011). *Further Education and Training (FET) colleges at a glance in 2010: FET colleges audit May-July 2010*. Pretoria: Human Sciences Research Council.
- Cresswell, J.W. (2007). *Qualitative inquiry and research design – Choosing among five approaches* (2nd ed.). London: SAGE Publications Ltd.
- Cresswell, J.W. (2011). *Educational Research: Planning, Conducting and Evaluating Quantitative and Qualitative Research* (4th ed.). Boston, MA: Pearson.
- Cresswell, J.W. (2014). *Research design – Qualitative, quantitative and mixed method approaches*. London: SAGE Publications Ltd.
- Csíkos, C., Rausch, A. & Sztányi, J. (Eds.). (2016). *Proceedings of the 40th Conference of the International Group for the Psychology of Mathematics Education*. Szeged, Hungary: International Group for the Psychology of Mathematics Education.
- Cullen, C.J. & Barrett, J.E. (2010). Strategy use indicative of an understanding of units in length. In M. Pinto & T. Kawasaki (Eds.), *Proceedings of the 34th Conference of the International Group for the Psychology of Mathematics Education* (Vol. 2) (pp. 281-288). Belo Horizonte, Brazil: International Group for the Psychology of Mathematics Education.
- Cullen, C. J., Miller, A. L., Barrett, J. E., Clements, D. H., & Sarama, J. (2011). Unit eliciting task structures: Verbal prompts for comparative measures. In B. Ubuz (Ed.), *Proceedings of the 35th Conference of the International Group for the Psychology of Mathematics Education* (Vol.1) (pp. 3-8). Ankara, Turkey: International Group for the Psychology of Mathematics Education.
- Curry, M., Mitchelmore, M.C. & Outhred, N.L. (2006). Development of children's understanding of length, area and volume measurement principles. In J. Novotná, H. Moraová, M. Krátká & N. Stehlíková (Eds.), *Proceedings of the 30th Conference of the International Group for the Psychology of Mathematics Education* (Vol. 2) (pp. 377-384). Prague, Czech Republic: International Group for the Psychology of Mathematics Education.
- Daniels, H. (2005). Introduction. In H. Daniels (Ed.), *An Introduction to Vygotsky* (pp. 1-31). London: Routledge.
- Dayimani, M. (2013, August 15). College strike continues. *Grocott's Mail*. Retrieved Jan 26, 2015, from <http://www.grocotts.co.za/content/college-strike-continues-15-08-2013>.

- De Beer, M. (2000). *Learning Potential Computerised Adaptive Test (LPCAT): User's Manual*. Pretoria: University of South Africa.
- De Beer, M. (2006). Dynamic testing: Practical solutions to some concerns. *South African Journal of Industrial Psychology*, 32(4), 8-14.
- Denzin, N.K. & Lincoln, Y.S. (2005). Introduction: The discipline and practice of qualitative research. In N.K. Denzin & Y.S. Guba (Eds.), *The SAGE Handbook of Qualitative Research* (3rd ed.) (pp. 1-32). London: SAGE Publications Ltd.
- Department of Basic Education. (2011a). *Curriculum and Assessment Policy Statement Grades 10 – 12 Mathematical Literacy*. Pretoria: Department of Basic Education.
- Department of Basic Education. (2011b). *Curriculum and Assessment Policy Statement Grades 4 – 6 Mathematics*. Pretoria: Department of Basic Education.
- Department of Basic Education. (2011c). *Curriculum and Assessment Policy Statement Grades 7 – 9 Mathematics*. Pretoria: Department of Basic Education.
- Department of Basic Education. (2011d). *Curriculum and Assessment Policy Statement Grades 10 – 12 Mathematics*. Pretoria: Department of Basic Education.
- Department of Basic Education. (2011e). *Curriculum and Assessment Policy Statement Grade R Mathematics*. Pretoria: Department of Basic Education.
- Department of Basic Education. (2014a). *The Annual National Assessment of 2014: Diagnostic Report – Intermediate and Senior Phases Mathematics*. Pretoria: Department of Basic Education.
- Department of Basic Education. (2014b). *Curriculum and Assessment Policy Statement Grades 10 – 12 Technical Mathematics*. Pretoria: Department of Basic Education.
- Department of Basic Education. (2015a). *Annual National Assessment: Grade 4 Mathematics Test*. Pretoria: Department of Basic Education.
- Department of Basic Education. (2015b). *Annual National Assessment: Grade 5 Mathematics Test*. Pretoria: Department of Basic Education.
- Department of Basic Education. (2015c). *Annual National Assessment: Grade 7 Mathematics Test*. Pretoria: Department of Basic Education.
- Department of Basic Education. (2015d). *Annual National Assessment: Grade 9 Mathematics Test*. Pretoria: Department of Basic Education.
- Department of Basic Education. (2015e). *Eastern Cape No Fee Schools 2015*. Retrieved June 26, 2016, from <http://www.education.gov.za/Portals/0/Documents/Publications/EC%20No%20Fee%20Schools%202015%20list.pdf?ver=2015-07-21-134533-227>
- Department of Basic Education. (2015f). *Free State No Fee Schools 2015*. Retrieved June 26, 2016, from <http://www.education.gov.za/Portals/0/Documents/Publications/FS%20No%20Fee%20Schools%202015%20list.pdf?ver=2015-07-21-135524-130>
- Department of Basic Education. (2015g). *National Senior Certificate Grade 12 Mathematics P1, November 2015*. Pretoria: Department of Basic Education.

- Department of Basic Education. (2016a). *Grade 6 Mathematics in English Book 1: Terms 1 & 2*. Pretoria: Department of Basic Education.
- Department of Basic Education. (2016b). *National Senior Certificate Grade 12 Mathematical Literacy P2, February-March 2016*. Pretoria: Department of Basic Education.
- Department of Education. (2007). *Policy Document on Adult Basic Education and Training*. Pretoria: Department of Education. Retrieved September 12, 2016 from <http://www.education.gov.za/Portals/0/Documents/Policies/GET/PolicyDocumentABET.pdf?ver=2007-08-22-081525-000>
- Department of Higher Education and Training. (2007). *National Certificates (Vocational) Subject Guidelines Applied Engineering Technology NQF Level 4*. Pretoria: Department of Higher Education and Training.
- Department of Higher Education and Training. (2011). *National Certificates (Vocational) Subject Guidelines Mathematics NQF Level 2*. Pretoria: Department of Higher Education and Training.
- Department of Higher Education and Training. (2012a). *Green Paper on Post-School Education and Training*. Pretoria: Department of Higher Education and Training.
- Department of Higher Education and Training. (2012b). *National Certificates (Vocational) Subject Guidelines Engineering Technology NQF Level 2*. Pretoria: Department of Higher Education and Training.
- Department of Higher Education and Training. (2012c). *National Skills Development Strategy III*. Pretoria: Department of Higher Education and Training.
- Department of Higher Education and Training. (2013a). *General Education and Training Certificate Adult Basic Education and Training – Examinations and Assessment Guidelines Mathematical Literacy L4*. Pretoria: Department of Higher Education and Training.
- Department of Higher Education and Training. (2013b). *General Education and Training Certificate Adult Basic Education and Training – Examinations and Assessment Guidelines Mathematics and Mathematical Sciences L4*. Pretoria: Department of Higher Education and Training.
- Department of Higher Education and Training. (2013c). *Department of Higher Education and Training Annual Report 2012/2013*. Pretoria: Department of Higher Education and Training.
- Department of Higher Education and Training. (2013d). *National Certificates (Vocational) Subject Guidelines Automotive Repair and Maintenance NQF Level 2*. Pretoria: Department of Higher Education and Training.
- Department of Higher Education and Training. (2013e). *National Certificates (Vocational) Subject Guidelines Fitting and Turning NQF Level 2*. Pretoria: Department of Higher Education and Training.

- Department of Higher Education and Training. (2013f). *National Certificates (Vocational) Subject Guidelines Welding NQF Level 2*. Pretoria: Department of Higher Education and Training.
- Department of Higher Education and Training. (2013g). *National Certificates (Vocational) Qualification NQF Levels 2, 3 & 4 Matrix of Subjects – 2013*. Pretoria: Department of Higher Education and Training.
- Department of Higher Education and Training. (2013h). *White Paper for Post-School Education and Training*. Pretoria: Department of Higher Education and Training.
- Department of Higher Education and Training. (2014). *Department of Higher Education and Training Annual Report 2013/2014*. Pretoria: Department of Higher Education and Training.
- Department of Higher Education and Training. (2015a). *Department of Higher Education and Training Annual Report 2014/2015*. Pretoria: Department of Higher Education and Training.
- Department of Higher Education and Training. (2015b). *National Certificates (Vocational) Subject Guidelines Automotive Repair and Maintenance NQF Level 4*. Pretoria: Department of Higher Education and Training.
- Department of Higher Education and Training. (2015c). *National Certificates (Vocational) Subject Guidelines Fitting and Turning NQF Level 4*. Pretoria: Department of Higher Education and Training.
- Department of Higher Education and Training. (2015d). *National Certificates (Vocational) Subject Guidelines Welding NQF Level 4*. Pretoria: Department of Higher Education and Training.
- Department of Higher Education and Training. (2016a). *Department of Higher Education and Training Annual Report 2015/2016*. Pretoria: Department of Higher Education and Training.
- Department of Higher Education and Training. (2016b). *Press Statement dated 29 January 2016*. Retrieved August 31, 2016 from <http://www.salabournews.co.za/press-releases/29661-dhet-40-in-mathematics-in-matric-is-a-requirement-for-artisan-consideration>.
- Department of Higher Education and Training. (2016c). *Statistics on Post-School Education and Training in South Africa: 2014*. Pretoria: Department of Higher Education and Training.
- Doig, B., Williams, J., Wo, L. & Pampaka, M. (2006). Integrating errors into developmental assessment: ‘Time’ for ages 8-13. In J. Novotná, H. Moraová, M. Krátká & N. Stehlíková (Eds.), *Proceedings of the 30th Conference of the International Group for the Psychology of Mathematics Education* (Vol. 2) (pp. 441-448). Prague, Czech Republic: International Group for the Psychology of Mathematics Education.

- Durkin, K. & Rittle-Johnson, B. (2015). Diagnosing misconceptions: Revealing changing decimal fraction knowledge. *Learning and Instruction*, 37, 21-29.
- Durrheim, K. (2006). Research design. In M. Terre Blanche, K. Durrheim & D. Painter (Eds.), *Research in practice: Applied methods for the social sciences* (pp. 33-59). Cape Town: UCT Press.
- Eisenberg, T., Goldstein, E. & Gorodetsky, M. (1982). On teaching the comparison of metric measurements in a vocational school. In A. Vermandel (Ed.), *Proceedings of the 6th PME International Conference*, 218-222.
- Engineering Council of South Africa. (2002). *Policy Statement R2/1B: Acceptable engineering work for candidate engineering technologists for registration as professional engineering technologists*. Engineering Council of South Africa. Retrieved September 1, 2016 from https://www.ecsa.co.za/ECSADocuments/ECSA%20Documents/Documents/2B_Technologists_PolicyStatementR2_1B.pdf
- Engineering Council of South Africa. (2004). *Policy Statement R2/1A: Acceptable Engineering Work for Candidate Engineers for Registration as Professional Engineers*. Johannesburg: Engineering Council of South Africa.
- Engineering Council of South Africa. (2012). *Submission to the Department of Higher Education and Training on the Green Paper on Post-School Education and Training*. Johannesburg: Engineering Council of South Africa.
- Engineering Council of South Africa. (2014). *Application Form: Registration as a Professional Engineering Technologist*. Johannesburg: Engineering Council of South Africa. Retrieved September 1, 2016 from <https://www.ecsa.co.za/register/SitePages/Apply%20for%20Registration.aspx>
- Engineering Council of South Africa. (2015a). *Qualification Standard for Diploma in Engineering: NQF Level 6*. Johannesburg: Engineering Council of South Africa.
- Engineering Council of South Africa. (2015b). *Qualification Standard for Higher Certificate in Engineering: NQF Level 5*. Johannesburg: Engineering Council of South Africa.
- Engineering Council of South Africa. (2016a). *The Engineering Development Process*. Johannesburg: Engineering Council of South Africa. Retrieved September 12, 2016 from <https://www.ecsa.co.za/prodevelopment/SitePages/Development%20Process.aspx>
- Engineering Council of South Africa. (2016b). *Qualification Standard for Advanced Certificate in Engineering: NQF Level 6*. Johannesburg: Engineering Council of South Africa.
- Engineering Council of South Africa. (2016c). *Qualification Standard for Advanced Diploma in Engineering: NQF Level 7*. Johannesburg: Engineering Council of South Africa.
- Engineering Council of South Africa. (2016d). *Qualification Standard for Bachelor of Engineering Technology: NQF Level 7*. Johannesburg: Engineering Council of South Africa.

- Engineering Council of South Africa. (2016e). *Qualification Standard for Bachelor of Engineering Technology Honours: NQF Level 8*. Johannesburg: Engineering Council of South Africa.
- Engineering Council of South Africa. (2016f). *Qualification Standard for Diploma in Engineering Technology: NQF Level 6*. Johannesburg: Engineering Council of South Africa.
- Ernest, P. (1998). *Social Constructivism as a Philosophy of Mathematics*. New York: State University of New York Press.
- Feikes, D., Schwingendorf, K. & Gregg, J. (2009). *Connecting Math for Elementary Teachers: How Children Learn Mathematics*. Valparaiso, IN: Pearson Higher Education.
- Fengu, M. (2013, January 31). Problems stalk King Hintsa FET. *Daily Dispatch*. Retrieved Jan 26, 2015, from <http://www.dispatchlive.co.za/news/problems-stalk-king-hintsa-fet/>.
- Figueras, O., Cortina, J.L., Alatorre, S., Rojano, T. & Sepúlveda, A. (Eds.). (2008). *Proceedings of the 32nd Conference of The International Group for the Psychology of Mathematics Education*. Morelia, Mexico: International Group for the Psychology of Mathematics Education.
- Flanagan, J.C. (1954). The Critical Incident Technique. *Psychological Bulletin*, 51(4), 327-358.
- Fox, N.J. (2007). Induction. In L.M. Given (Ed.), *The SAGE Encyclopaedia of Qualitative Research Methods* (pp. 429-430). London: SAGE Publications Ltd.
- Fuchs, L.S., Compton, D.L., Fuchs, D., Hollenbeck, K.N., Hamlett, C.L. & Seethaler, P.M. (2011). Two-stage screening for math problem-solving difficulty using dynamic assessment of algebraic learning. *Journal of Learning Disabilities*, 44(4), 372-380.
- Fujita, H., Hashimoto, Y., Hodgson, B.R., Peng, Y., Lerman, S. & Sawada, T. (Eds.). (2004). *Proceedings of the Ninth International Congress on Mathematical Education*. Dordrecht: Kluwer Academic Publishers.
- Furinghetti, F. & Giacardi, L. (2012). *The First Century of the International Commission for Mathematics Instruction (1908 – 2008)*. Retrieved July 31, 2016 from <http://www.icmihistory.unito.it/congress.php>
- Further Education and Training Round Table. (2010). *Document for discussion: Challenges facing the FET college subsystem, towards finding resolutions in partnership with stakeholders*. Round Table Working Document. Retrieved August 10, 2010 from www.jet.org.za/events/fet-college-round-table.../reports.
- Gavin, M. K., Casa, T. M., Adelson, J. L., & Firmender, J. M. (2013). The impact of challenging geometry and measurement units on the achievement of grade 2 students. *Journal for Research in Mathematics Education*, 44(3), 478-509.
- Geertz, C. (1973). *Interpretation of Cultures: Selected Essays by Clifford Geertz*. New York: Basic Books, Inc.

- Gibson, B.B. (2008). Video recording. In L.M. Given (Ed.), *The SAGE Encyclopaedia of Qualitative Research Methods* (pp. 916-918). London: SAGE Publications Ltd.
- Gillham, S. (2013, October 10). Bay students on the rampage. *The Herald*. Retrieved Jan 26, 2015, from <http://www.heraldive.co.za/bay-students-on-the-rampage/>.
- Golafshani, N. (2003). Understanding reliability and validity in qualitative research. *The Qualitative Report*, 8(4), 597-606.
- Goldin, G.A. (1997). Observing mathematical problem solving through task-based interviews. *Journal for Research in Mathematics Education*, 9, 40-62.
- Goldin, G.A. (2000). A scientific perspective on structured, task-based interviews in mathematics education research. In A.E. Kelly, R.A. Lesh (Eds.), *Handbook of Design in Mathematics and Science Education* (pp. 517-545). London: Lawrence Erlbaum Associates.
- Gooya, Z., Khosroshahi, L. G., & Teppo, A. R. (2011). Iranian students' measurement estimation performance involving linear and area attributes of real-world objects. *The International Journal of Mathematics Education ZDM*, 43(5), 709-722.
- Gowa, M. (2013, April 29). Lovedale students ordered to go home. *Daily Dispatch*. Retrieved Jan 26, 2015, from <http://www.dispatchlive.co.za/news/lovedale-students-ordered-to-go-home/>.
- Grant, D. (2013). *Background to the national quintile system*. Cape Town: Western Cape Education Department. Retrieved 27 June, 2016 from http://wced.pgwc.gov.za/comms/press/2013/74_14oct.html
- Gutiérrez, A. & Boero, P. (Eds.). (2006). *Handbook of Research on the Psychology of Mathematics Education: Past, Present and Future*. Rotterdam: Sense Publishers.
- Haggis, T. (2006). Pedagogies for diversity: Retaining critical challenges amidst fears of 'dumbing down'. *Studies in Higher Education*, 31(5), 521-535.
- Hall, R. (2000). Videorecording as theory. In A.E. Kelly, R.A. Lesh (Eds.), *Handbook of Design in Mathematics and Science Education* (pp. 647-664). London: Lawrence Erlbaum Associates.
- Hannighofer, J., Van den Heuvel-Panhuizen, M., Weirich, S. & Robitzsch, A. (2011). Revealing German primary school students' achievement in measurement. *The International Journal of Mathematics Education ZDM*, 43(5), 651-666.
- Harrison, J.K. & Lee, R. (2011). Exploring the use of critical incident analysis and the professional learning conversation in an initial teacher education programme. *Journal of Education for Teaching*, 37(2), 199-217.
- Hedges, H. (2012). Vygotsky's phases of everyday concept development and the notion of children's 'working theories'. *Learning, Culture and Social Interaction*, 1, 143-152.
- Hiebert, J. (1981). Cognitive development and learning linear measurement. *Journal for Research in Mathematics Education*, 197-211.

- Hiebert, J. & Lefevre, P. (1986). Conceptual and procedural knowledge in mathematics: An introductory analysis. In J. Hiebert (Ed.), *Conceptual and procedural knowledge: The case of mathematics* (1-28). Hillsdale, NJ: Lawrence Erlbaum Associates, Inc.
- Houston, J., Booyse, C. & Burroughs, E. (2010). *The 'F' in NC(V) – Benchmarking common subjects in the NSC and the NC(V)*. Pretoria: Umalusi.
- Howie, S., van Staden, S., Tshele, M., Dowse, C. & Zimmerman, L. (2012). *Progress in International Reading Literacy Study 2011: South African Children's Reading Literacy Achievement Summary Report*. Pretoria: Centre for Evaluation and Assessment, University of Pretoria.
- Huang, H.M.E. (2012). An exploration of computer-based curricula for teaching children volume measurement concepts. In T.Y. Tso (Ed.), *Proceedings of the 36th Conference of the International Group for the Psychology of Mathematics Education* (Vol. 2) (pp. 351-322). Taipei, Taiwan: International Group for the Psychology of Mathematics Education.
- Huang, H.M.E. (2014a). Investigating children's ability to solve measurement estimation problems. In P. Liljedahl, C. Nicol, S. Oesterle & D. Allan (Eds.), *Proceedings of the 38th Conference of the International Group for the Psychology of Mathematics Education and the 36th Conference of the North American Chapter of the Psychology of Mathematics Education* (Vol. 3) (pp. 353-360). Vancouver, Canada: International Group for the Psychology of Mathematics Education.
- Huang, H.M.E. (2014b). Third-to fourth-grade students' conceptions of multiplication and area measurement. *The International Journal of Mathematics Education ZDM*, 46(3), 449-463.
- Huang, H.M.E. (2015). Children's performance in estimating the measurements of daily objects. In K. Beswick, T. Muir & J. Wells (Eds.), *Proceedings of the 39th Conference of the International Group for the Psychology of Mathematics Education* (Vol. 3) (pp. 73-80). Hobart, Tasmania: International Group for the Psychology of Mathematics Education.
- Huang, H.M.E. & Su, Y.H. (2016). The effects of estimation interventions on children's measurement estimation performance. In C. Csikos, A. Rausch, & J. Sztányi (Eds.), *Proceedings of the 40th Conference of the International Group for the Psychology of Mathematics Education* (Vol. 2) (pp. 417-424). Szeged, Hungary: International Group for the Psychology of Mathematics Education.
- Human Resource Development Council of South Africa. (2016). The challenge of developing artisans. *South African Business*. Retrieved October 1, 2016 from <https://www.matchdeck.com/article/7093-the-challenge-of-developing-artisans-clone#/index>.
- Huntington, J. R. (1970). Linear Measurement in the Primary Grades: A Comparison of Piaget's Description of the Child's Spontaneous Conceptual Development and the SMSG Sequence of Instruction. *Journal for Research in Mathematics Education*, 219-232.
- Hurst, C. (2008). Using task-based interviews to assess mathematical thinking of primary school students. In M. Goos, R. Brown & K. Makar (Eds.), *Proceedings of the 31st Annual Conference of the Mathematics Education Research Group of Australasia* (pp. 273-280). Brisbane: MERGA.

- Iannece, D., Mellone, M. & Tortora, R. (2009). Counting vs. measuring: Reflections on number roots between epistemology and neuroscience. In M. Tzekaki, Kaldrimidou, M. & H. Sakonidis (Eds.), *Proceedings of the 33rd Conference of the International Group for the Psychology of Mathematics Education* (Vol. 3) (pp. 209-216). Thessaloniki, Greece: International Group for the Psychology of Mathematics Education.
- Iannece, D., Mellone, M. & Tortora, R. (2010). Multiplicative thought: A kindergarten path. In M. Pinto & T. Kawasaki (Eds.), *Proceedings of the 34th Conference of the International Group for the Psychology of Mathematics Education* (Vol. 3) (pp. 121-127). Belo Horizonte, Brazil: International Group for the Psychology of Mathematics Education.
- Inamdar, S. (2012). *Flow of fluids in pipes*. University of Delaware: Watershed Sciences Research Group. Retrieved Dec 18, 2012, from <http://udel.edu/~inamdar/EGTE215/Pipeflow.pdf>
- International Congress on Mathematics Instruction. (2007). *Topic Study Groups at ICME-11*. Retrieved 31 July, 2016 from tsg.icme11.org.
- International Congress on Mathematics Instruction. (2016). *Topic Study Groups at ICME-13*. Retrieved 31 July, 2016 from icme13.org/topic_study_groups.
- Johri, A. & Olds, B.M. (2011). Situated engineering learning: Bridging engineering education research and the learning sciences. *Journal of Engineering Education*, 100(1), 151-185.
- Joram, E., Gabriele, A. J., Bertheau, M., Gelman, R., & Subrahmanyam, K. (2005). Children's use of the reference point strategy for measurement estimation. *Journal for Research in Mathematics Education*, 4-23.
- Joram, E., Subrahmanyam, K. & Gelman, R. (1998). Measurement estimation: Learning to map the route from number to quantity and back. *Review of Educational Research*, 68(4), 413-449.
- Kamii, C., & Russell, K. A. (2010). The older of two trees: Young children's development of operational time. *Journal for Research in Mathematics Education*, 41(1), 6-13.
- Kamii, C., & Russell, K. A. (2012). Elapsed time: why is it so difficult to teach? *Journal for Research in Mathematics Education*, 43(3), 296-315.
- Kent, P., Bakker, A., Hoyles, C. & Noss, R. (2011). Measurement in the workplace: the case of process improvement in manufacturing industry. *The International Journal of Mathematics Education ZDM*, 43(5), 747-758.
- Kidder, F. R., & Lamb, C. E. (1981). Conservation of Length: An Invariant: A Study and a Follow-up. *Journal for Research in Mathematics Education*, 12(3), 225-230.
- Kizito, R.N. (2014). *Designing assessment tasks*. Presentation at the Workshop for Earth Sciences Department. University of the Western Cape, Cape Town.
- Kolver, L. (2014). Decade of the Artisan Programme launched, 30 000 artisans a year targeted. *Engineering News*. Retrieved October 1, 2016 from <http://www.engineeringnews>.

co.za/article/decade-of-the-artisan-programme-launched-30-000-artisans-a-year-targeted-2014-02-03/rep_id:4136

- Kontorovich, I., & Zazkis, R. (2016). Turn vs. Shape: Teachers Cope with Incompatible Perspectives on Angle. *Educational Studies in Mathematics*, 93(2), 223-243.
- Kospentaris, G., Spyrou, P., & Lappas, D. (2011). Exploring students' strategies in area conservation geometrical tasks. *Educational Studies in Mathematics*, 77(1), 105-127.
- Kyriakides, A.O. (2006). Modelling fractions with area: The salience of vertical partitioning. In J. Novotná, H. Moraová, M. Krátká & N. Stehlíková (Eds.), *Proceedings of the 30th Conference of the International Group for the Psychology of Mathematics Education* (Vol. 4) (pp. 17-24). Prague, Czech Republic: International Group for the Psychology of Mathematics Education.
- LaCroix, L. (2014). Learning to see pipes mathematically: preapprentices' mathematical activity in pipe trades training. *Educational Studies in Mathematics*, 86(2), 157-176.
- Lamon, S.J. (2008). *Teaching fractions and ratios for understanding: Essential content knowledge and instructional strategies for teachers* (2nd ed.). London: Lawrence Erlbaum Associates.
- Lamon, S.J. (2012). *Teaching fractions and ratios for understanding: Essential content knowledge and instructional strategies for teachers* (3rd ed.). London: Lawrence Erlbaum Associates.
- Lantolf, J.P. & Poehner, M.E. (2011). Dynamic assessment in the classroom: Vygotskian praxis for second language development. *Language Teaching Research*, 15(1), 11-33.
- Lee, K., & Smith, J. P. (2011). What is different across an ocean? How Singapore and US elementary mathematics curricula introduce and develop length measurement. *The International Journal of Mathematics Education ZDM*, 43(5), 681-696.
- Lehrer, R., Min-Joung, K. & Jones, R.S. (2011). Developing conceptions of statistics by designing measures of distribution. *The International Journal of Mathematics Education ZDM*, 43(5), 723-736.
- Lelliott, A. (2010). The concept of spatial scale in astronomy addressed by an informal learning environment. *African Journal of Research in Mathematics, Science and Technology Education*, 14(3), 20-33.
- Lesh, R. (2000). Iterative refinement cycles for videotape analyses of conceptual change. In A.E. Kelly, R.A. Lesh (Eds.), *Handbook of Design in Mathematics and Science Education* (pp. 665-708). London: Lawrence Erlbaum Associates.
- Liljedahl, P., Nicol, C., Oesterle, S. & Allan, D. (Eds.) (2014). *Proceedings of the 38th Conference of the International Group for the Psychology of Mathematics Education and the 36th Conference of the North American Chapter of the Psychology of Mathematics Education*. Vancouver, Canada: International Group for the Psychology of Mathematics Education.

- Lima, R.N. & Tall, D. (2010). *An example of the fragility of a procedural approach to solving equations (draft)*. Retrieved July 10, 2013 from <http://homepages.warwick.ac.uk/staff/David.Tall/pdfs/dot2010x-lima-quadratics-draft.pdf>
- Lincoln, Y.S. & Guba, E. (1985). *Naturalistic Inquiry*. Beverley Hills: Sage.
- Lindmeier, A. & Heinze, A. (Eds.). (2013). *Proceedings of the 37th Conference of the International Group for the Psychology of Mathematics Education*. Kiel, Germany: International Group for the Psychology of Mathematics Education.
- Lister, P.G. & Crisp, B.R. (2007). Critical incident analyses: A practice learning tool for students and practitioners. *Practice: Social Work in Action*, 19(1), 47-60.
- Lotz-Sisitka, H. & McKenna, S. (2015). *Introductory perspectives: Southern African school and post-schooling systems and contemporary challenges, indicating the need for new educational knowledge in society*. Lecture presented at the International Exchange Week (Rhodes University, South Africa, Faculty of Education in partnership with Umea University, Sweden, Faculty of Education): Education, the public good and transformative practices, Rhodes University, Grahamstown, South Africa.
- Lourenço, O. & Machado, A. (1996). In defence of Piaget's theory: A reply to 10 common criticisms. *Psychological Review*, 103(1), 143-164.
- MacDonald, A. (2011). Young children's representations of their developing measurement understanding. In J. Clark, B. Kissane, J. Mousley, T. Spencer, S. Thornton (Eds.), *Mathematics: Traditions and [New] Practices: Proceedings of the AAMT-MERGA Conference* (pp. 482-490). Adelaide: AAMT & MERGA.
- Machaba, F. M. (2016). The concepts of area and perimeter: Insights and misconceptions of Grade 10 learners. *Pythagoras*, 37(1), 1-11.
- MacKenzie, N. & Knipe, S. (2006). Research dilemmas: Paradigms, methods and methodology. *Issues in Educational Research*, 16, 1-14.
- Magajna, Z., & Monaghan, J. (2003). Advanced mathematical thinking in a technological workplace. *Educational Studies in Mathematics*, 52(2), 101-122.
- Maher, C.A. & Sigley, R. (2014). Task-based interviews in mathematics education. In S. Lerman (Ed.), *Encyclopaedia of Mathematics Education* (pp. 579-582). Netherlands: Springer.
- Makholwa, A. (2015). Artisans: Gap in the economic plan. *Financial Mail*. Retrieved August 31, 2016 from <http://www.financialmail.co.za/features/2015/05/28/artisans-gap-in-the-economic-plan>.
- Mamona-Downs, J. & Papadopoulos, I. (2006). The problem-solving element in young students' work related to the concept of area. In J. Novotná, H. Moraová, M. Krátká & N. Stehlíková (Eds.), *Proceedings of the 30th Conference of the International Group for the Psychology of Mathematics Education* (Vol. 4) (pp. 121-128). Prague, Czech Republic: International Group for the Psychology of Mathematics Education.

- Mardis, M.A., Hoffman, E.S. & Rich, P.J. (2008). Trends and issues in qualitative research methods. In J. M. Spector, M. D. Merrill, J.V. van Merriënboer & M.P. Driscoll (Eds.), *Handbook of research on educational communications and technology* (3rd ed.) (pp. 173-193). New York: Taylor & Francis Group.
- Marock, C., Hazell, E. & Akhoobai, B. (2016). What will it take to turn TVET colleges around? Evaluation of a large-scale college improvement programme. In A. Kraak, A. Paterson & B. Kedibone (Eds.), *Change management in TVET colleges: Lessons learnt from the field of practice* (pp. 103 – 119). Cape Town: African Minds.
- Maton, K. (2014). *Knowledge and knowers: Towards a realist sociology of education*. Oxon: Routledge.
- Matshoba, H. & Burroughs, E. (2013). *The Ns and the Engineering NC(V)s: A comparison of selected engineering subjects within the National Certificate N2 – N3 and selected programmes of the National Certificate (Vocational)*. Pretoria: Umalusi.
- Mbonambi, M. S., & Bansilal, S. (2014). Comparing Grade 11 Mathematics and Mathematical Literacy learners' algebraic proficiency in temperature conversion problems. *African Journal of Research in Mathematics, Science and Technology Education*, 18(2), 198-209.
- McAuliffe, M., Hargreaves, D., Winter, A. & Chadwick, G. (2008). *Does pedagogy still rule?* Paper presented at the 2008 Australasian Association for Engineering Education Conference, Yeppoon, Australia.
- McDonough, A., & Cheeseman, J. (2014). Young learners' understandings about mass measurement: Insights from an open-ended task. In P. Liljedahl, C. Nicol, S. Oesterle & D. Allan (Eds.), *Proceedings of the 38th Conference of the International Group for the Psychology of Mathematics Education and the 36th Conference of the North American Chapter of the Psychology of Mathematics Education* (Vol. 3) (pp. 193-200). Vancouver, Canada: International Group for the Psychology of Mathematics Education.
- Mhlolo, M. K., & Schafer, M. (2013). 'The Area of a Triangle is 1800C'—An Analysis of Learners' Idiosyncratic Geometry Responses through the Lenses of Vygotsky's Theory of Concept Formation. *African Journal of Research in Mathematics, Science and Technology Education*, 17(1-2), 83-93.
- Miles, T.A. (2009). *Implementation of Qualifications*. Workshop presented at South African Nursing Council Nursing Education Association Conference. Johannesburg, South Africa.
- Miller, R. (2011). *Vygotsky in Perspective*. Cambridge: Cambridge University Press.
- Mitchelmore, M.C. & White, P. (2000). Development of angle concepts by progressive abstraction and generalisation. *Educational Studies in Mathematics*, 41(3), 209-238.
- Moloi, M.Q. & Chetty, M. (2010). *The SACMEQ III Project in South Africa: A study of the conditions of schooling and the quality of education: South Africa, Country Report*. Pretoria: Department of Basic Education.

- Montgomery, M. E. (1973). The interaction of three levels of aptitude determined by a teach-test procedure with two treatments related to area. *Journal for Research in Mathematics Education*, 271-278.
- Moore, K. C. (2013). Making sense by measuring arcs: A teaching experiment in angle measure. *Educational Studies in Mathematics*, 83(2), 225-245.
- Mullis, I.V.S., Martin, M.O., Foy, P. & Arora, A. (2012). *TIMSS 2011 International Results in Mathematics*. Amsterdam: International Association for the Evaluation of Educational Achievement.
- National Planning Commission. (2012). *National Development Plan 2030: Our Future – make it work*. Pretoria: National Planning Commission.
- Needham, S. & Papier, J. (2012). *Practical matters: What young people think about vocational education in South Africa*. London: City and Guilds.
- Niss, M. (Ed.).(2008). *ICME-10 Proceedings*. Denmark: IMFUFA, Department of Science, Systems and Models, Roskilde University.
- Nkonkobe, Z. (2013, October 18). Students to protest over funding. *Daily Dispatch*. Retrieved Jan 26, 2015, from <http://www.dispatchlive.co.za/news/students-to-protest-over-funding-aid/>.
- Novotná, J., Moraová, H., Krátká, M. & Stehlíková, N. (Eds.). (2006). *Proceedings of the 30th Conference of the International Group for the Psychology of Mathematics Education*. Prague, Czech Republic: International Group for the Psychology of Mathematics Education.
- Nunes, T., Light, P. & Mason, J. (1993). Tools for thought: The measurement of length and area. *Learning and Instruction*, 3, 39-54.
- Onwuegbuzie, A.J. & Daniel, L.G. (2003). Typology of analytical and interpretational errors in quantitative and qualitative research. *Current Issues in Education*, 6(2), 1-34.
- Onwuegbuzie, A.J. & Leech, N.L. (2007). Validity and qualitative research: An oxymoron? *Quality and Quantity*, 41, 233-249.
- Outhred, L.N. & Mitchelmore, M.C. (2000). Young children's intuitive understanding of rectangular area measurement. *Journal for Research in Mathematics Education*, 31(2), 144-167.
- Owens, K. & Outhred, L. (2006). The complexity of learning geometry and measurement. In A. Gutiérrez & P. Boero (Eds.), *Handbook of Research on the Psychology of Mathematics Education: Past, Present and Future* (pp. 83-115). Rotterdam: Sense Publishers.
- Palys, T. Purposive Sampling. In L.M. Given (Ed.), *The SAGE Encyclopaedia of Qualitative Research Methods* (pp. 697-698). London: SAGE Publications Ltd.
- Papier, J. (2009). *Getting the right learners into the right programmes: An investigation into factors that contributed to the poor performance of FET college learners in the NCV 2 and*

- NCV 3 programmes in 2007 and 2008 – Reasons and recommendations*. University of the Western Cape: FET Institute.
- Papier, J., Needham, S. & McBride, T. (2012). *Contemporary Issues in Public FET Colleges*. Cape Town: Human Sciences Research Council, Labour Market Intelligence Partnership.
- Parliament of South Africa. (2013, October). Trouble continues at FET colleges. *Insession*, 13(9). Retrieved Jan 26, 2015, from http://www.parliament.gov.za/live/content.php?Item_ID=5185.
- Passelaigue, D., & Munier, V. (2015). Schoolteacher trainees' difficulties about the concepts of attribute and measurement. *Educational Studies in Mathematics*, 89(3), 307-336.
- Paterson, A. (2016). Perspectives and programmes, projects and policies in the TVET colleges. In A. Kraak, A. Paterson & B. Kedibone (Eds.), *Change management in TVET colleges: Lessons learnt from the field of practice* (pp. viii - xxiii). Cape Town: African Minds.
- Phakathi, B. (2013). Majority of schools in Western Cape granted no-fee status. *Business Day Live*. Retrieved 1 July, 2016 from <http://www.bdlive.co.za/national/education/2013/11/19/majority-of-schools-in-western-cape-granted-no-fee-status>.
- Phillips, D.C. (1995). The good, the bad, and the ugly: The many faces of constructivism. *Educational Researcher*, 24, 5-12.
- Piaget, J. (1964). Development and Learning. In M. Gauvain & M. Cole (Eds.), *Readings on the Development of Children* (pp. 19-28). New York: W.H. Freeman and Company.
- Piaget, J. (1970). *The Principles of Genetic Epistemology*. London: Routledge.
- Piaget, J. (1972). Intellectual evolution from adolescence to adulthood. *Human Development*, 15, 1-12.
- Piaget, J., Inhelder, B. & Szeminska, A. (1960). *The Child's Conception of Geometry*. Oxon: Routledge.
- Pinto, M. & Kawasaki, T. (Eds.). (2010). *Proceedings of the 34th Conference of the International Group for the Psychology of Mathematics Education*. Belo Horizonte, Brazil: International Group for the Psychology of Mathematics Education.
- PISA. (2015). *Draft collaborative problem solving framework*. Paris: Organisation for Economic Co-operation and Development.
- Pitta-Pantazi, D., & Christou, C. (2009). Cognitive styles, dynamic geometry and measurement performance. *Educational Studies in Mathematics*, 70(1), 5-26.
- Pittalis, M., & Christou, C. (2010). Types of reasoning in 3D geometry thinking and their relation with spatial ability. *Educational Studies in Mathematics*, 75(2), 191-212.
- Preston, R. & Thompson, T. (2004). Integrating measurement across the curriculum. *Mathematics Teaching in the Middle School*, 9(8), 436-441.
- Poehner, M.E. & Lantolf, J.P. (2010). Vygotsky's teaching assessment dialectic and L2 education: The case for dynamic assessment. *Mind, Culture and Activity*, 17(4), 312-330.

- Poehner, M.E. & van Compernelle, R.A. (2011). Frames of interaction in dynamic assessment: Developmental diagnoses of second language learning. *Assessment in Education: Principles, Policy and Practice*, 18(2), 183-198.
- Powell, L. (2012). Re-imagining the purpose of VET – Expanding the capability to aspire in South African Further Education and Training students. *International Journal of Educational Development*, 32(5), 643 – 653.
- Powell, L. (2013). A critical assessment of research on South African further education and training colleges. *Southern African Review of Education*, 19(1), 59 – 81.
- Powell, L. & Lolwana, P. (2012). *From reconstruction to deconstruction – The role of research in South African skills development*. Paper presented at the Association for the Development of Education in Africa Triennale Meeting, Ouagadougou, Burkina Faso.
- Powell, L. & McGrath, S. (2014). Exploring the value of the capability approach for vocational education and training evaluation: Reflections from South Africa. In G. Carbonnier, M. Carton & K. King (Eds.), *Education, Learning, Training: Critical Issues for Development* (pp. 126 – 148). Boston: Brill-Nijhoff.
- Rasool, H. & Mahembe, E. (2014). *FET colleges' purpose in the developmental state: Imperatives for South Africa*. Pretoria: Human Resources Development Council of South Africa.
- Republic of South Africa. (2000). Engineering Profession Act, Act No. 46 of 2000. *Government Gazette*. (Vol. 1821, No. 1304).
- Republic of South Africa. (2009). Minimum admission requirements for Higher Certificate, Diploma, and Degree programmes requiring a National Certificate (Vocational) at Level 4 of the National Qualifications Framework. *Government Gazette*. (Vol. 533, No. 32743).
- Republic of South Africa. (2012). Listing of occupations as trades for which artisan qualifications are required. *Government Gazette*. (Vol. 566, No. 35625).
- Revina, S., Zulkardi, Z., Darmawijoyo, D. & van Galen, F. (2011). Spatial visualisation tasks to support students' spatial structuring in learning volume measurement. *Journal of Mathematics Education*, 2(2), 127 – 146.
- Reynolds, A., & Wheatley, G. H. (1996). Elementary students' construction and coordination of units in an area setting. *Journal for Research in Mathematics Education*, 564-581.
- Romberg, T. A., & Gilbert, L. E. (1972). The effect of training on length on the performance of kindergarten children on nonstandard but related tasks. *Journal for Research in Mathematics Education*, 69-75.
- Ronan, W.W. & Latham, G.P. (1974). The reliability and validity of the critical incident technique: A closer look. *Studies in Personnel Psychology*, 6(1), 53-64.
- Rowlands, S. & Carson, R. (2001). The contradictions in the constructivist discourse. *Philosophy of Mathematics Education Journal*, 14, 1-15.

- Ruwisch, S., Heid, M. & Weiher, D.F. (2015). Measurement estimation in primary school: Which answer is adequate? In K. Beswick, T. Muir & J. Wells (Eds.), *Proceedings of the 39th Conference of the International Group for the Psychology of Mathematics Education* (Vol. 4) (pp. 113-120). Hobart, Tasmania: International Group for the Psychology of Mathematics Education.
- Sarama, J. & Clements, D.H. (2009). *Early Childhood Mathematics Education Research: Learning Trajectories for Young Children*. New York: Routledge.
- Sarama, J., Clements, D.H., Barrett, J., van Dine, D.W. & McDonel, J.S. (2011). Evaluation of a learning trajectory for length in the early years. *The International Journal of Mathematics Education*, 43, 667-680.
- Saumure, K. & Given, L.M. (2008). Data saturation. In L.M. Given (Ed.), *The SAGE Encyclopaedia of Qualitative Research Methods* (pp. 195-196). London: SAGE Publications Ltd.
- Savenye, W.C. & Robinson, R.R. (2004). Qualitative research issues and methods: An introduction for educational technologists. In D.H. Jonasson (Ed.), *Handbook of Research on Educational Communications and Technology* (2nd ed.) (pp. 1045-1071). London: Lawrence Erlbaum Associates.
- Savenye, W.C., Robinson, R., Niemczyk, M. & Atkinson, R. (2008). Assessment of individual learning processes. In J. M. Spector, M. D. Merrill, J.V. van Merriënboer & M.P. Driscoll (Eds.), *Handbook of research on educational communications and technology* (3rd ed.) (pp. 767-776). New York: Taylor & Francis Group.
- Schensul, J.J. (2008). Methodology. In L.M. Given (Ed.), *The SAGE Encyclopaedia of Qualitative Research Methods* (pp. 516-521). London: SAGE Publications Ltd.
- Schuh, K.L. & Barab, S.A. (2008). Philosophical perspectives. In J. M. Spector, M. D. Merrill, J.V. van Merriënboer & M.P. Driscoll (Eds.), *Handbook of research on educational communications and technology* (3rd ed.) (pp. 67-80). New York: Taylor & Francis Group.
- Schwandt, T.A. (2007). *The SAGE Dictionary of Qualitative Inquiry*. London: SAGE Publications Ltd.
- Select Committee on Education and Recreation. (2006). *Further Education and Training Colleges Bill*. Republic of South Africa.
- Simon, M., Saldanha, L., McClintock, E., Akar, G.K., Watanabe, T. & Zembat, I.O. (2010). A developing approach to studying students' learning through their mathematical activity. *Cognition and Instruction*, 28(1), 70-112.
- Sinclair, M., Mamolo, A., & Whiteley, W. J. (2011). Designing spatial visual tasks for research: the case of the filling task. *Educational Studies in Mathematics*, 78(2), 135-163.
- Skemp, R.R. (1989). *Mathematics in the Primary School*. London: Routledge Falmer.
- Smith, J.P., van den Heuvel-Panhuizen, M. & Teppo, A.R. (2011). Learning, teaching and using measurement: Introduction to the issue. *The International Journal of Mathematics Education ZDM*, 43(5), 617-620.

- Sota, O. (2014). Decade of the Artisan Programme officially launched. *South African Broadcasting Commission News*. Retrieved October 1, 2016 from <http://www.sabc.co.za/news/a/9fe4e680461e4f45978cb796e5573d3a/Decade-of-the-Artisan-Programme-officially-launched-20141107>
- South African Government News Agency. (2016). *DM Manana encourages learners to be artisans*. Retrieved September 12, 2016 from <http://www.sanews.gov.za/south-africa/dm-manana-encourages-learners-be-artisans>.
- South African Qualifications Authority. (2012). *Level Descriptors for the South African National Qualifications Authority*. Waterkloof: South African Qualifications Authority.
- South African Qualifications Authority. (2013). *National Policy for the Implementation of the Recognition of Prior Learning*. Waterkloof: South African Qualifications Authority.
- South African Qualifications Authority. (2015). *General Education and Training Certificate: Adult Basic Education and Training*. Retrieved June 26, 2016, from <http://regqs.sqaq.org.za/showQualification.php?id=71751>.
- Spaull, N. (2012). *Education in SA: A tale of two systems*. Johannesburg: PoliticsWeb. Retrieved June 26, 2016 from <http://www.politicsweb.co.za/opinion/education-in-sa-a-tale-of-two-systems>
- Spaull, N. (2013). *South Africa's Education Crisis: The Quality of Education in South Africa 1994 – 2011*. Johannesburg: Centre for Development and Enterprise.
- Sporre, K. (2015). *Education and the Public Good – on the matter of values in times of measurements*. Lecture presented at the International Exchange Week (Rhodes University, South Africa, Faculty of Education in partnership with Umea University, Sweden, Faculty of Education): Education, the public good and transformative practices, Rhodes University, Grahamstown, South Africa.
- Stake, R.E. (2005). Qualitative case studies. In N.K. Denzin & Y.S. Guba (Eds.), *The SAGE Handbook of Qualitative Research* (3rd ed.) (pp. 443-466). London: SAGE Publications Ltd.
- Stake, R.E. (2010). *Qualitative research – Studying how things work*. London: The Guilford Press.
- Statistics South Africa. (2013). *The World of Work*. Retrieved June 26, 2016 from <http://www.statssa.gov.za/?p=1034>.
- Statistics South Africa. (2016). *Quarterly Labour Force Survey: Quarter 1 2016*. Pretoria: Statistics South Africa.
- Stebbins, R.A. (2007). Exploratory research. In L.M. Given (Ed.), *The SAGE Encyclopaedia of Qualitative Research Methods* (pp. 327-329). London: SAGE Publications Ltd.
- Szilágyi, J., Clements, D. H., & Sarama, J. (2013). Young children's understandings of length measurement: Evaluating a learning trajectory. *Journal for Research in Mathematics Education*, 44(3), 581-620.

- Tall, D. (2006). *Encouraging mathematical thinking that has both power and simplicity*. Paper presented at the APEC-Tsukuba International Conference, Tokyo, Japan.
- Tall, D. (2008). *The historical and individual development of mathematical thinking: Ideas that are set-before and met-before*. Plenary presented at Colóquio de História e Tecnologia no Ensino da Matemática UFRJ, Rio de Janeiro, Brazil.
- Tall, D. (2013a). *How humans learn to think mathematically: Exploring the three worlds of mathematics*. Cambridge: Cambridge University Press.
- Tall, D. (2013b). *Integrating history, technology and education in mathematics*. Plenary presented at História e Tecnologia no Ensino da Matemática, Universidade Federal de São Carlos, Brazil.
- Taloumis, T. (1975). The relationship of area conservation to area measurement as affected by sequence of presentation of Piagetian area tasks to boys and girls in grades one through three. *Journal for Research in Mathematics Education*, 232-242.
- Tanguay, D., & Venant, F. (2016). The semiotic and conceptual genesis of angle. *The International Journal of Mathematics Education ZDM*, 48(6), 875-894.
- Tan-Sisman, G. & Aksu, M. (2016). A study on sixth grade students' misconceptions and errors in spatial measurement: Length, area and volume. *International Journal of Science and Mathematics Education*, 14(7), 1293-1319.
- Thompson, P.W. (1994). The development of the concepts of speed and its relation to the concepts of rate. In G. Harel & J. Confrey (Eds.), *The development of multiplicative reasoning in the learning of mathematics* (pp. 181-234). New York: SUNY Press.
- Thompson, P.W. & Thompson, A.G. (1994). Talking about rates conceptually, Part I: A teacher's struggle. *Journal for Research in Mathematics Education*, 25(3), 279-303.
- Thompson, A.G. & Thompson, P.W. (1996). Talking about rates conceptually, Part II: Mathematical knowledge for teaching. *Journal for Research in Mathematics Education*, 27(1), 2-24.
- Tobin, K. (2000). Interpretive research in science education. In A.E. Kelly & R.A. Lesh (Eds.), *Handbook of Research Design in Mathematics and Science Education* (pp. 487-512). London: Lawrence Erlbaum Associates, Inc.
- Toerner, G. & Arzarello, F. (2012). Grading Mathematics Education Research Journals. *Newsletter of the European Mathematical Society*, 86, 52-54.
- Torbeyns, J., Schneider, M., Ziqiang, X. & Siegler, R.S. (2015). Bridging the gap: Fraction understanding is central to mathematics achievement in students from three different continents. *Learning and Instruction*, 37, 5-13.
- Tso, T.Y. (Ed.). (2012). *Proceedings of the 36th Conference of the International Group for the Psychology of Mathematics Education*. Taipei, Taiwan: International Group for the Psychology of Mathematics Education.

- Tzekaki, M., Kaldrimidou, M. & Sakonidis, H. (Eds.). (2009). *Proceedings of the 33rd Conference of the International Group for the Psychology of Mathematics Education*. Thessaloniki, Greece: International Group for the Psychology of Mathematics Education.
- Ubuz, B. (Ed.). (2011). *Proceedings of the 35th Conference of the International Group for the Psychology of Mathematics Education*. Ankara, Turkey: International Group for the Psychology of Mathematics Education.
- Umalusi. (2010). *The 'F' in NC(V) – Benchmarking common subjects in the NSC and the NC(V)*. Pretoria: Umalusi.
- UNESCO. (2015). *Rethinking Education: Towards a global common good?* Paris: UNESCO.
- UNEVOC. (2014). *Vocational Pedagogy: What it is, why it matters and how to put it into practice*. Bonn: UNESCO-UNEVOC International Centre for Technical and Vocational Education and Training.
- Vale, P. (2014, January). *Using collaboratively framed dynamic assessment to develop a method for the analysis of adult students' conceptual understanding of measurement*. Paper presented at the 22nd Annual Meeting of the Southern African Association for Research in Mathematics, Science and Technology Education (SAARMSTE), Nelson Mandela Metropolitan University, Port Elizabeth, South Africa.
- Vale, P. (2015a, March). *Technical and vocational education and training: The need for a fresh research approach*. Paper presented at the International Exchange Week (Rhodes University (South Africa), Faculty of Education in partnership with Umea University (Sweden), Faculty of Education: Education, the public good and transformative practices, Rhodes University, Grahamstown, South Africa.
- Vale, P. (2015b, June). *Patterns emerging from a qualitative analysis of vocational engineering students' engagement in measurement tasks*. Paper presented at the Post-Graduate Colloquium of the Eastern Cape Chapter of the South African Association for Research in Mathematics, Science and Technology Education, Nelson Mandela Metropolitan University, Port Elizabeth, South Africa.
- Vale, P. (2015c, August). *Embedding numeracy practices in post-school vocational curricula: A case study of TVET Engineering students' learning of measurement*. Keynote address at Numeracy in Higher Education Colloquium, Durban University of Technology, Durban, South Africa.
- Vale, P. (2015d, September). *The value of peer collaborative tasks and dynamic approaches to assessment in encouraging the development of positive learner dispositions to mathematics*. Plenary presentation at AMESA Eastern Cape Regional Conference, Rhodes University, Grahamstown, South Africa.
- Vale, P. (2016). *Developing the ability to use measurement concepts and skills in and for work: The value of collaborative tasks*. Paper presented at the 13th International Congress on Mathematics Education, 24-31 July 2016, Hamburg, Germany.

- Vamvakoussi, S. & Vosniadu, S. (2010). How many decimals are there between two fractions? Aspects of secondary school students' understanding of rational numbers and their notation. *Cognition and Instruction*, 28(2), 181-209.
- Van den Heuvel-Panhuizen, M., & Elia, I. (2011). Kindergartners' performance in length measurement and the effect of picture book reading. *The International Journal of Mathematics Education ZDM*, 43(5), 621-635.
- Van Gog, T., Remy, M., Rikers, J.P. & Ayres, P. (2008). Assessment of complex performance. In J. M. Spector, M. D. Merrill, J.V. van Merriënboer & M.P. Driscoll (Eds.), *Handbook of research on educational communications and technology* (3rd ed.) (pp. 783-789). New York: Taylor & Francis Group.
- Van Wageningen, R. K., Flora, J. A., & Walker, A. A. (1976). The introduction of mathematics through measurement or through set theory: A comparison. *Journal for Research in Mathematics Education*, 299-307.
- van Wyk, C. (2015). An overview of education data in South Africa: an inventory approach. *South African Journal of Childhood Education*, 5(2), 123-145.
- Villette, F. (2016). Sharp rise in no-fee school pupils. *Cape Times*. Retrieved June 27, 2016 from <http://www.iol.co.za/capetimes/sharp-rise-in-no-fee-school-pupils-2031750>.
- Vistro-Yu, C.P. (2000). *Children's understanding of basic measurement concepts: A cultural perspective*. Regular lecture presented at the 9th International Congress on Mathematics Education, Tokyo, Japan.
- Voulgaris, S. & Evangelidou, A. (2004). Volume conception in late primary school children in Cyprus. *Quaderni di Ricerca in Didattica*, 14, 1-32.
- Vygotsky, L.S. (1926/1986). *Thought and Language*. (A. Kozulin, Trans.). Cambridge, MA: The MIT Press.
- Vygotsky, L.S. (1978). *Mind in Society: The development of higher psychological processes*. Cambridge, MA: Harvard University Press.
- Vygotsky, L.S. (1987). The development of scientific concepts in childhood. In R.W. Rieber (Ed.), *The collected works of L.S. Vygotsky: Volume 1, Problems of General Psychology* (pp. 167-242). New York: Plenum Press.
- Wang, T.H. (2011). Implementation of web-based dynamic assessment in facilitating junior high school students to learn mathematics. *Computers and Education*, 56, 1062-1071.
- Wellington, J. (2015). *Educational Research: Contemporary Issues and Practical Approaches*. London: Bloomsbury.
- Wertsch, J.V. (2007). Mediation. In H. Daniels, M. Cole & J.V. Wertsch (Eds.), *The Cambridge Companion to Vygotsky* (pp. 178-192). Cambridge: Cambridge University Press.

- Woo, J.H., Lew, H.C., Park, K.S. & Seo, D.Y. (Eds.). (2007). *Proceedings of the 31st Conference of International Group for the Psychology of Mathematics Education*. Seoul, Korea: International Group for the Psychology of Mathematics Education.
- Yim, J. (2010). Children's strategies for division by fractions in the context of the area of a rectangle. *Educational Studies in mathematics*, 73(2), 105-120.
- Young, R.A. & Collin, A. (2004). Introduction: Constructivism and social constructionism in the career field. *Journal of Vocational Behaviour*, 64, 373-388.
- Yujing, N. & Zhou, Y.D. (2005). Teaching and learning fractions and rational numbers: The origins and implications of whole number bias. *Educational Psychologist*, 40(1), 27-52.
- Zhang, J. (2010). Vygotsky's thinking: Its relevance to learning and education. *Mind, Culture and Activity*, 17(2), 188-190.

APPENDICES

APPENDIX A

Survey of PME Measurement Research Reports

Year	Publication Name	Articles
2006	<i>Proceedings of the 30th Conference of PME</i> Prague, Czech Republic Novotná, Moraová, Krátká & Stehlíková (2006)	Development of children's understanding of length, area and volume measurement principles (Curry, Mitchelmore & Outhred, 2006) Integrating errors into developmental assessment: 'time' for ages 8-13 (Doig, Linda, Wo & Pampaka, 2006) Modelling fractions with area: The salience of vertical partitioning (Kyriakides, 2006) The problem-solving element in young students' work related to the concept of area (Mamona-Downs & Papadopoulos, 2006)
2007	<i>Proceedings of the 31st Conference of PME</i> Seoul, Korea Woo, Lew, Park & Seo (2007)	none
2008	<i>Proceedings of the 32nd Conference of PME</i> Morelia, Mexico Figuera, Cortina, Alatorre, Rojano & Sepúlveda (2008)	none
2009	<i>Proceedings of the 33rd Conference of PME</i> Thessaloniki, Greece Tzekaki, Kaldrimidou, Sakonidis (2009)	Counting vs. measuring: Reflections on number roots between epistemology and neuroscience (Iannece, Mellone & Tortora, 2009)
2010	<i>Proceedings of the 34th Conference of PME</i> Belo Horizonte, Brazil Pinto & Kawasaki (2010)	Early Multiplicative thought: A kindergarten path (Iannece, Mellone & Tortora, 2010) Strategy use indicative of an understanding of units of length. (Cullen & Barrett, 2010)
2011	<i>Proceedings of the 35th Conference of PME</i> Ankara, Turkey Ubuz (2011)	Unit eliciting task structures: A comparison (Cullen, Miller, Barrett, Clements & Sarama, 2011)
2012	<i>Proceedings of the 36th Conference of PME</i> Taipei, Taiwan Tso (2012)	An exploration of computer-based curricula for teaching children volume measurement concepts (Huang, 2012)
2013	<i>Proceedings of the 37th Conference of PME</i> Kiel, Germany	none

	Lindmeier & Heinze (2013)	
2014	<p><i>Proceedings of the 38th Conference of PME</i></p> <p>Vancouver, Canada</p> <p>Liljedahl, Nicol, Oesterle & Allan (2014)</p>	<p>Investigating Children's Ability to Solve Measurement Estimation Problems (Huang, 2014a)</p> <p>Linking Children's Knowledge of Length Measurement to Their Use of Double Number Lines (Beck, Eames, Cullen, Barrett, Clements & Sarama, 2014)</p> <p>Young Learners' Understandings About Mass Measurement: Insights from An Open-Ended Task (McDonough & Cheeseman, 2014)</p>
2015	<p><i>Proceedings of the 39th Conference of PME</i></p> <p>Hobart, Tasmania</p> <p>Beswick, Muir & Wells (2015)</p>	<p>Children's performance in estimating the measurements of daily objects (Huang, 2015)</p> <p>Measurement estimation in primary school: Which answer is adequate (Ruwisch, Heid & Weiher, 2015)</p>
2016	<p><i>Proceedings of the 40th Conference of PME</i></p> <p>Szeged, Hungary</p> <p>Csikos, Rausch & Sztányi</p>	<p>Reciprocal relations of relative size in the instructional context of fractions as measures (Cortina & Visnovska, 2016)</p> <p>The effects of estimation interventions on children's measurement estimation performance (Huang & Su, 2016)</p>

APPENDIX B

Survey of Measurement Research in 5 Peer-Reviewed Mathematics Education Journals

Toerner and Arzarello (2012), in research conducted for the European Society for Research in Mathematics Education, consulted 91 experts, representing 42 countries to grade journals according to the following criteria: recognition; review process and quality; composition of the editorial board; and citations. Journals were graded on a scale of A* (the highest) to C. This, in part, guided the selection of journals for the survey. Both A*-grade journals and one A-grade journals were consulted in this measurement research survey. In addition, a regional (African) journal, as well as one South African [SA] academic mathematics education journal, were included in the survey.

The selected journals were:

<u>A* grade</u>	Educational Studies in Mathematics (1968 – 2012) Journal for the Research of Mathematics Education (1976 – 2016)
<u>A grade</u>	The International Journal for Mathematics Education ZDM (1997 – 2016)
<u>African</u>	African Journal for Research in Mathematics, Science and Technology Education (1997 – 2016)
<u>SA</u>	Pythagoras (2004 – 2016)

Type of journal	Journal Name	Articles (in chronological order)
A* Graded	Educational Studies in Mathematics (1968 – 2012)	<p><u>1996</u>: Student teachers' subject matter knowledge within the domain of area measurement (Baturu & Nason, 1996)</p> <p><u>1996</u>: Development of turn and turn measurement concepts in a computer-based instructional unit (Clements, Battista, Sarama & Swaminathan, 1996)</p> <p><u>2000</u>: Development of angle concepts by progressive abstraction and generalisation (Mitchelmore & White, 2000)</p> <p><u>2000</u>: Students' development of strategies for turn and angle measure (Clements & Burns, 2000)</p> <p><u>2003</u>: Advanced Mathematical thinking in a technological workplace (Magaina & Monaghan, 2003)</p> <p><u>2009</u>: Cognitive styles, dynamic geometry and measurement performance (Pitta-Pantazi, & Christou, 2009)</p> <p><u>2010</u>: Types of reasoning in 3D geometry thinking and their relation with spatial ability (Pittalis & Christou, 2010)</p>

		<p><u>2010</u>: Children’s strategies for division by fractions in the context of area of a rectangle (Yim, 2010)</p> <p><u>2011</u>: Exploring students’ strategies in area conservation geometrical tasks (Kospentaris, Spyrou & Lappas, 2011)</p> <p><u>2011</u>: Designing spatial visual tasks for research: The case of the filling task (Sinclair, Mamolo & Whiteley, 2011)</p> <p><u>2013</u>: Making sense by measuring arcs: A teaching experiment in angle measure (Moore, 2013)</p> <p><u>2014</u>: Learning to see pipes mathematically: Pre-apprentices’ mathematical activity in pipe trades training (LaCroix, 2014)</p> <p><u>2015</u>: Schoolteacher trainees’ difficulties about the concepts of attribute and measurement (Passelaigue & Munier, 2015)</p> <p><u>2016</u>: Turn vs. shape: teachers cope with incompatible perspectives on angle (Kontorovich & Zazkis, 2016)</p>
<p>Journal for the Research of Mathematics Education</p> <p>(1976 – 2016)</p>		<p><u>1970</u>: Linear measurement in the primary grades: A comparison of Piaget’s description of the child’s spontaneous conceptual development and the SMSG sequence of instruction (Huntington, 1970)</p> <p><u>1972</u>: The effect of training on length on the performance of kindergarten children on nonstandard but related tasks (Romberg & Gilbert, 1972)</p> <p><u>1973</u>: The interaction of three levels of aptitude determined by a teach-test procedure with two treatments related to area (Montgomery, 1973)</p> <p><u>1975</u>: Measurement concepts of first- and second-grade students (Carpenter, 1975)</p> <p><u>1975</u>: The relationship of area conservation to area measurement as affected by sequence of presentation of Piagetian area tasks to boys and girls in Grades one through three (Taloumis, 1975)</p> <p><u>1976</u>: The introduction of mathematics through measurement or through set theory: A comparison (van Wageningen, Flora & Walker, 1976)</p> <p><u>1976</u>: The development of the concept of a standard unit of measure in young children (Carpenter & Lewis, 1976)</p> <p><u>1981</u>: Cognitive development and learning linear measurement (Hiebert, 1981)</p> <p><u>1981</u>: Conservation of length: An invariant: A study and a follow-up (Kidder & Lamb, 1981)</p>

		<p><u>1994</u>: Talking about rates conceptually, Part I: A teacher's struggle (Thompson & Thompson, 1994)</p> <p><u>1996</u>: Talking about rates conceptually, Part II: Mathematical knowledge for teaching (Thompson & Thompson, 1996)</p> <p><u>1996</u>: Elementary students' construction and coordination of units in an area setting (Reynolds & Wheatley, 1996)</p> <p><u>1997</u>: Students' development of length concepts in a logo-based unit on geometric paths (Clements, Battista, Sarama, Swaminathan & McMillen, 1997)</p> <p><u>1998</u>: Students' spatial structuring of 2D arrays of squares (Battista, Clements, Arnoff, Battista, Van Aucken & Borrow, 1998)</p> <p><u>2000</u>: Young children's intuitive understanding of rectangular area measurement (Outhred & Mitchelmore, 2000)</p> <p><u>2005</u>: Children's use of the reference point strategy for measurement estimation (Joram, Gabriele, Bertheau, Gelman & Subrahmanyam, 2005)</p> <p><u>2006</u>: Students' coordination of geometric reasoning and measuring strategies on a fixed perimeter task: Developing mathematical understanding of length measurement (Barrett, Clements, Klanderma, Pennisi & Polaki, 2006)</p> <p><u>2010</u>: The older of two trees: Young children's development of operational time (Kamii & Russell, 2010)</p> <p><u>2012</u>: Elapsed time: Why is it so difficult to teach? (Kamii & Russell, 2012)</p> <p><u>2013</u>: Young children's understandings of length measurement: Evaluating a learning trajectory (Szilágyi, Clements & Sarama, 2013)</p> <p><u>2013</u>: The impact of challenging geometry and measurement units on the achievement of Grade 2 students (Gavin, Casa, Adelson & Firmender, 2013)</p>
A graded	The International Journal for Mathematics Education ZDM (1997 – 2016)	<p><u>2011</u>: The use, nature and purposes of measurement in intermediate-level occupations (Bakker, Wijers, Jonker, & Akkerman, 2011)</p> <p><u>2011</u>: Children's unit concepts in measurement: A teaching experiment spanning Grades 2 through 5 (Barrett, Cullen, Sarama, Clements, Klanderma, Miller & Rumsey, 2011)</p> <p><u>2011</u>: Exploring US textbooks' treatment of the estimation of linear measurements (Chang, Males, Mosier & Gonulates, 2011)</p>

		<p>2011: Iranian students’ measurement estimation performance involving linear and area attributes of real-world objects (Gooya, Khosroshahi & Teppo, 2011)</p> <p>2011: Revealing German primary school students’ achievement in measurement (Hannighofer, van den Heuvel-Panhuizen, Weirich & Robitzsch, 2011)</p> <p>2011: Measurement in the workplace: The case of process improvement in manufacturing industry (Kent, Bakker, Hoyles & Noss, 2011)</p> <p>2011: What is different across an ocean? How Singapore and US elementary mathematics curricula introduce and develop length measurement (Lee & Smith, 2011)</p> <p>2011: Developing conceptions of statistics by designing measurement of distribution (Lehrer, Kim & Jones, 2011)</p> <p>2011: Evaluation of a learning trajectory for length in the early years (Sarama, Clements, Barrett, van Dine & McDonel, 2011)</p> <p>2011: Kindergartner’s performance in length measurement and the effect of picture book reading (van den Heuvel-Panhuizen & Elia, 2011)</p> <p>2014: Third- to fourth-grade students’ conceptions of multiplication and area measurement (Huang, 2014b)</p> <p>2016: The semiotic and conceptual genesis of angle (Tanguay, & Venant, 2016)</p> <p>2016: Comparison of perimeters: Improving students’ performance by increasing the salience of the relevant variable (Babai, Nattiy & Stavy, 2016)</p>
Regional (African) journal	African Journal for Research in Mathematics, Science and Technology Education (1997 – 2016)	<p>2013: ‘The area of a triangle is 180°: An analysis of learners’ idiosyncratic geometry responses through the lenses of Vygotsky’s theory of concept formation (Mhlolo & Schafer, 2013)</p> <p>2013: The concept of spatial scale in astronomy addressed by an informal learning environment (Lelliott, 2013)</p> <p>2014: Comparing Grade 11 Mathematics and Mathematical Literacy algebraic proficiency in temperature conversion problems (Mbonambi & Bansilal, 2014)</p>
Local (South African) academic journal	Pythagoras (2004 – 2016)	<p>2016: The concepts of area and perimeter: Insights and misconceptions of Grade 10 learners (Machaba, 2016)</p>

APPENDIX C

NC(V) Engineering Programmes of Study

**DEPARTMENT OF HIGHER EDUCATION AND TRAINING
NATIONAL CERTIFICATE (VOCATIONAL) QUALIFICATION NQF LEVELS 2, 3 & 4
MATRIX OF SUBJECTS - 2013**

*NB: (O) = OPTIONAL SUBJECTS**

** OPTIONAL SUBJECTS CAN ALSO BE CHOSEN FROM ANY OTHER PROGRAMMES**

	Level 2 SAQA ID NO: 50440	Level 3 SAQA ID NO: 50442	Level 4 SAQA ID NO: 50441
<p><i>Fundamentals*</i> <i>*Note:</i> <i>The 3 fundamental subjects are compulsory</i> <i>The 3 core vocational subjects are also compulsory</i> <i>A 4th vocational subject must be taken but can also be a vocational subject from another programme</i></p>	<ul style="list-style-type: none"> • English/Afrikaans/IsiXhosa (First Additional language) • Life Orientation • Mathematics OR Mathematical Literacy 	<ul style="list-style-type: none"> • English/Afrikaans/IsiXhosa (First Additional language) • Life Orientation • Mathematics OR Mathematical Literacy 	<ul style="list-style-type: none"> • English/Afrikaans/IsiXhosa (First Additional language) • Life Orientation • Mathematics OR Mathematical Literacy
<p>1. Civil Engineering & Building Construction</p>	<ul style="list-style-type: none"> • Construction Planning • Materials • Plant and Equipment • Carpentry and Roof Work (O)* <p>OR</p> <ul style="list-style-type: none"> • Concrete Structures (O)* 	<ul style="list-style-type: none"> • Construction Planning • Materials • Plant and Equipment • Carpentry and Roof Work (O)* <p>OR</p> <ul style="list-style-type: none"> • Concrete Structures (O)* 	<ul style="list-style-type: none"> • Construction Planning • Materials • Construction Supervision • Carpentry and Roof Work (O)* <p>OR</p> <ul style="list-style-type: none"> • Concrete Structures (O)*

	OR <ul style="list-style-type: none"> • Masonry (O)* OR <ul style="list-style-type: none"> • Physical Science(O)* OR <ul style="list-style-type: none"> • Plumbing (O)* OR <ul style="list-style-type: none"> • Roads (O)* 	OR <ul style="list-style-type: none"> • Masonry (O)* OR <ul style="list-style-type: none"> • Physical Science (O)* OR <ul style="list-style-type: none"> • Plumbing (O)* OR <ul style="list-style-type: none"> • Roads (O)* 	OR <ul style="list-style-type: none"> • Masonry (O)* OR <ul style="list-style-type: none"> • Physical Science (O)* OR <ul style="list-style-type: none"> • Plumbing (O)* OR <ul style="list-style-type: none"> • Roads (O)*
2. Drawing Office Practice	<ul style="list-style-type: none"> • Architectural Graphics and Technology • Civil and Structural Steel work Detailing • Engineering Graphics and Technology • Drawing Office Procedures and Techniques (O)* 	<ul style="list-style-type: none"> • Architectural Graphics and Technology • Civil and Structural Steel work Detailing • Engineering Graphics and Design • Drawing Office Procedures and Techniques (O)* 	<ul style="list-style-type: none"> • Architectural Graphics and Technology • Civil and Structural Steel work Detailing • Mechanical Draughting and Technology • Drawing Office Procedures and Techniques (O)*
4. Electrical Infrastructure Construction	<ul style="list-style-type: none"> • Electrical Principles and Practice • Electronic Control and Digital Electronics • Workshop Practice • Electrical Systems and Construction (O)* OR <ul style="list-style-type: none"> • Physical Science (O)* 	<ul style="list-style-type: none"> • Electrical Principles and Practice • Electronic Control and Digital Electronics • Electrical Workmanship • Electrical Systems and Construction (O)* OR <ul style="list-style-type: none"> • Physical Science (O)* 	<ul style="list-style-type: none"> • Electrical Principles and Practice • Electronic Control and Digital Electronics • Electrical Workmanship • Electrical Systems and Construction (O)* OR <ul style="list-style-type: none"> • Physical Science(O)*
5. Engineering and Related Design	<ul style="list-style-type: none"> • Engineering Fundamentals • Engineering Systems • Engineering Technology 	<ul style="list-style-type: none"> • Engineering Practice and Maintenance • Engineering Graphics and Design • Materials Technology 	<ul style="list-style-type: none"> • Engineering Processes • Applied Engineering Technology • Professional Engineering Practice

	<ul style="list-style-type: none"> Automotive Repair & Maintenance (O)* OR <ul style="list-style-type: none"> Engineering Fabrication (O)* OR <ul style="list-style-type: none"> Fitting and Turning(O) * OR <ul style="list-style-type: none"> Physical Science (O)* OR <ul style="list-style-type: none"> Refrigeration Principles (O)* OR <ul style="list-style-type: none"> Welding (O)* 	<ul style="list-style-type: none"> Automotive Repair & Maintenance(O)* OR <ul style="list-style-type: none"> Engineering Fabrication-Boiler making (O)* OR <ul style="list-style-type: none"> Engineering Fabrication – Sheet Metal Work(O)* OR <ul style="list-style-type: none"> Fitting and Turning(O)* OR <ul style="list-style-type: none"> Physical Science (O)* OR <ul style="list-style-type: none"> Refrigeration Practice (O)* OR <ul style="list-style-type: none"> Welding (O)* 	<ul style="list-style-type: none"> Automotive Repair & Maintenance(O)* OR <ul style="list-style-type: none"> Engineering Fabrication-Boiler making (O)* OR <ul style="list-style-type: none"> Engineering Fabrication – Sheet Metal Work(O)* OR <ul style="list-style-type: none"> Fitting and Turning(O)* OR <ul style="list-style-type: none"> Physical Science (O)* OR <ul style="list-style-type: none"> Refrigeration and Air-conditioning Processes (O)* OR <ul style="list-style-type: none"> Welding (O)*
8. Information Technology & Computer Science	<ul style="list-style-type: none"> Electronics Introduction to Information Systems Introduction to Systems Development Contact Centre Operations(O)* OR <ul style="list-style-type: none"> Multimedia Basics (O)* 	<ul style="list-style-type: none"> Computer Hardware and Software Systems Analysis and Design Principles of Computer Programming Contact Centre Operations(O)* OR <ul style="list-style-type: none"> Multimedia Content (O)* 	<ul style="list-style-type: none"> Data Communication and Networking Systems Analysis and Design Computer Programming Contact Centre Operations(O)* OR <ul style="list-style-type: none"> Multimedia Service (O)*
11. Mechatronics	<ul style="list-style-type: none"> Electrotechnology Introduction to Computers Manual Manufacturing Mechatronic Systems (O)* 	<ul style="list-style-type: none"> Electrotechnology Stored Programme Systems Machine Manufacturing Mechatronic Systems (O)* 	<ul style="list-style-type: none"> Electrotechnology Stored Programme Systems Computer-Integrated Manufacturing Mechatronic Systems (O)*

14. Process Instrumentation	<ul style="list-style-type: none"> • Electronic Control and Digital Electronics • Engineering Fundamentals • Physical Science • Instrumentation Technology (O)* 	<ul style="list-style-type: none"> • Electronic Control and Digital Electronics • Engineering Practice and Maintenance • Physical Science • Instrumentation Technology (O)* 	<ul style="list-style-type: none"> • Electronic Control and Digital Electronics • Engineering Processes • Physical Science • Instrumentation Technology (O)*
15. Process Plant Operations	<ul style="list-style-type: none"> • Engineering Fundamentals • Physical Science • Process Technology • Process Chemistry (O)* <p>OR</p> <ul style="list-style-type: none"> • Pulp and Papermaking Technology (O)* 	<ul style="list-style-type: none"> • Process Control • Physical Science • Process Technology • Process Chemistry (O)* <p>OR</p> <ul style="list-style-type: none"> • Pulp and Papermaking Technology (O)* 	<ul style="list-style-type: none"> • Process Control • Physical Science • Process Technology • Process Chemistry (O)* <p>OR</p> <ul style="list-style-type: none"> • Pulp and Papermaking Technology (O)*

(From DHET, 2013g)

APPENDIX D

NQF Level Descriptors: Levels 1 - 4

NQF LEVEL 1

- a. Scope of knowledge, in respect of which a learner is able to demonstrate a general knowledge of one or more areas or fields of study, in addition to the fundamental areas of study.
- b. Knowledge literacy, in respect of which a learner is able to demonstrate an understanding that knowledge in a particular field develops over a period of time through the efforts of a number of people, and often through the synthesis of information from a variety of related sources and fields.
- c. Method and procedure, in respect of which a learner is able to demonstrate the ability to use key common tools and instruments, and a capacity to apply him/herself to a well-defined task under direct supervision.
- d. Problem solving, in respect of which a learner is able to demonstrate the ability to recognise and solve problems within a familiar, well-defined context.
- e. Ethics and professional practice, in respect of which a learner is able to demonstrate the ability to identify and develop own personal values and ethics, and the ability to identify ethics applicable in a specific environment.
- f. Accessing, processing and managing information, in respect of which a learner is able to demonstrate the ability to recall, collect and organise given information clearly and accurately, sound listening and speaking (receptive and productive language use), reading and writing skills, and basic numeracy skills including an understanding of symbolic systems.
- g. Producing and communicating information, in respect of which a learner is able to demonstrate the ability to report information clearly and accurately in spoken/signed and written form.
- h. Context and systems, in respect of which a learner is able to demonstrate an understanding of the context within which he/she operates.
- i. Management of learning, in respect of which a learner is able to demonstrate the ability to sequence and schedule learning tasks, and the ability to access and use a range of learning resources.
- j. Accountability, in respect of which a learner is able to demonstrate the ability to work as part of a group.

NQF Level 2

- a. Scope of knowledge, in respect of which a learner is able to demonstrate a basic operational knowledge of one or more areas or fields of study, in addition to the fundamental areas of study.
- b. Knowledge literacy, in respect of which a learner is able to demonstrate an understanding that one's own knowledge of a particular field or system develops through active participation in relevant activities.
- c. Method and procedure, in respect of which a learner is able to demonstrate the ability to use a variety of common tools and instruments, and a capacity to work in a disciplined manner in a well-structured and supervised environment.
- d. Problem solving, in respect of which a learner is able to demonstrate the ability to use own knowledge to select and apply known solutions to well-defined routine problems.
- e. Ethics and professional practice, in respect of which a learner is able to demonstrate the ability to apply personal values and ethics in a specific environment.
- f. Accessing, processing and managing information, in respect of which a learner is able to demonstrate the ability to apply literacy and numeracy skills to a range of different but familiar contexts.
- g. Producing and communicating information, in respect of which a learner is able to demonstrate the basic ability to collect, organise and report information clearly and accurately, and the ability to express an opinion on given information clearly in spoken/signed and written form.
- h. Context and systems, in respect of which a learner is able to demonstrate an understanding of the environment within which he/she operates in a wider context.
- i. Management of learning, in respect of which a learner is able to demonstrate the capacity to learn in a disciplined manner in a well-structured and supervised environment.
- j. Accountability, in respect of which a learner is able to demonstrate the ability to manage own time effectively, the ability to develop sound working relationships, and the ability to work effectively as part of a group.

NQF Level 3

- a. Scope of knowledge, in respect of which a learner is able to demonstrate a basic understanding of the key concepts and knowledge of one or more fields or disciplines, in addition to the fundamental areas of study.
- b. Knowledge literacy, in respect of which a learner is able to demonstrate an understanding that knowledge in a field can only be applied if the knowledge, as well as its relationship to other relevant information in related fields, is understood.
- c. Method and procedure, in respect of which a learner is able to demonstrate operational literacy, the capacity to operate within clearly defined contexts, and the ability to work within a managed environment.
- d. Problem solving, in respect of which a learner is able to demonstrate the ability to use own knowledge to select appropriate procedures to solve problems within given parameters.
- e. Ethics and professional practice, in respect of which a learner is able to demonstrate the ability to comply with organisational ethics.
- f. Accessing, processing and managing information, in respect of which a learner is able to demonstrate the basic ability to summarise and interpret information relevant to the context from a range of sources, and the ability to take a position on available information, discuss the issues and reach a resolution.
- g. Producing and communicating information, in respect of which a learner is able to produce a coherent presentation and report, providing explanations for positions taken.
- h. Context and systems, in respect of which a learner is able to demonstrate an understanding of the organisation or operating environment as a system, and application of skills in measuring the environment using key instruments and equipment.
- i. Management of learning, in respect of which a learner is able to demonstrate the ability to learn within a managed environment.
- j. Accountability, in respect of which a learner is able to demonstrate the capacity to actively contribute to team effectiveness.

NQF Level 4

- a. Scope of knowledge, in respect of which a learner is able to demonstrate a fundamental knowledge base of the most important areas of one or more fields or disciplines, in addition to the fundamental areas of study, and a fundamental understanding of the key terms, rules, concepts, established principles and theories in one or more fields or disciplines.
- b. Knowledge literacy, in respect of which a learner is able to demonstrate an understanding that knowledge in one field can be applied to related fields.
- c. Method and procedure, in respect of which a learner is able to demonstrate the ability to apply essential methods, procedures and techniques of the field or discipline to a given familiar context, and the ability to motivate a change using relevant evidence.
- d. Problem solving, in respect of which a learner is able to demonstrate the ability to use own knowledge to solve common problems within a familiar context, and the ability to adjust an application of a common solution within relevant parameters to meet the needs of small changes in the problem or operating context with an understanding of the consequences of related actions.
- e. Ethics and professional practice, in respect of which a learner is able to demonstrate the ability to adhere to organisational ethics and a code of conduct, and the ability to understand societal values and ethics.
- f. Accessing, processing and managing information, in respect of which a learner is able to demonstrate a basic ability in gathering relevant information, analysis and evaluation skills, and the ability to apply and carry out actions by interpreting information from text and operational symbols or representations.
- g. Producing and communicating information, in respect of which a learner is able to demonstrate the ability to communicate and present information reliably and accurately in written and in oral or signed form.
- h. Context and systems, in respect of which a learner is able to demonstrate an understanding of the organisation or operating environment as a system within a wider context.
- i. Management of learning, in respect of which a learner is able to demonstrate the capacity to take responsibility for own learning within a supervised environment, and the capacity to evaluate own performance against given criteria.
- j. Accountability, in respect of which a learner is able to demonstrate the capacity to take decisions about and responsibility for actions, and the capacity to take the initiative to address any shortcomings found.

(From SAQA, 2012, p. 5 – 8)

APPENDIX E

General Descriptions of Measurement Learning for Intermediate Phase, Senior Phase & ABET L4

GRADE 4	GRADE 5	GRADE 6	GRADE 7	GRADE 8	GRADE 9	ABET L4
<p>The main progression in measurement across the grades is achieved by:</p> <ul style="list-style-type: none"> - the introduction of new measuring units, particularly in grades 4 and 6 - the increase in number range and complexity of calculations that learners are able to do in each grade <p>Practical measuring using measuring instruments is central to measurement in this phase</p>			<p>The main progression in measurement across the grades is achieved by the selection of shapes and objects in each grade for which the formulae for finding area, perimeter, surface area and volume become more complex</p> <p>The use of formulae in this phase provides a useful context to practice solving equations</p> <p>The introduction of the Theorem of Pythagoras is a way of introducing a formula to calculate the lengths of sides in right-angled triangles. Hence the Theorem of Pythagoras becomes a useful tool when learners solve geometric problems involving right-angled triangles</p>			<p>ABET Level 4 is a qualification at NQF Level 1, (equivalent to Grade 9)</p> <p>Students choose to complete either Mathematical Literacy Unit Standards OR Mathematics and Mathematical Sciences Unit Standards</p> <p>In Mathematical Literacy there is a dual focus on the use of formulae to calculate measurements and the use of appropriate practical measuring instruments to measure quantities</p> <p>In Mathematics and Mathematical Sciences there is a specific, singular focus on use of formulae to calculate quantities</p>
<p>Learners should be exposed to a variety of measurement activities</p> <p>Learners should be introduced to the use of standardised units of measurement and appropriate instruments for measuring. They should be able to estimate and verify results through accurate measurement</p>			<p>Learners should be using formulae to calculate area, perimeter, surface area and volume of geometric figures and solids</p> <p>Students should be able to calculate the area of polygons by decomposition into triangles and rectangles</p>			<p><u>Measurement in Mathematical Literacy:</u></p> <p>Students should be using formulae to calculate area, perimeter and volume</p> <p>Students should be able to calculate the area of polygons by decomposition into triangles and rectangles</p> <p>Students should be selecting and converting between appropriate SI units of measurement</p>

<p>Learners should be able to select and convert between appropriate units of measurement</p> <p>Measurement should also enable the learner to:</p> <ul style="list-style-type: none"> - informally measure angles, area, perimeter and volume/capacity <p>Measurement provides a context for learners to use common fractions and decimal fractions</p>	<p>Learners should be selecting and converting between appropriate units of measurement</p> <p>Learners should be using the Theorem of Pythagoras to solve problems involving right-angled triangles</p>	<p>Students should be using formulae and SI units to show the relationships and differences between different measurements</p> <p>Students should use measuring instruments to measure and calculate quantities in a variety of contexts</p> <p><u>Measurement in Mathematics and Mathematical Sciences</u></p> <p>Students should be using the Theorem of Pythagoras to solve problems involving right-angled</p> <p>Students should select the correct formulae to solve problems</p> <p>Units should be used correctly and students should be able to convert SI units</p>
---	--	---

Adapted from DBE (2011b); DBE (2011c); DHET (2013a); DHET (2013b) & SAQA (2015)

APPENDIX F

Curriculum Progression of Measurement Learning (Intermediate Phase & Senior Phase)

LENGTH					
GRADE 4	GRADE 5	GRADE 6	GRADE 7	GRADE 8	GRADE 9
<p><u>Practical measuring of 2-D shapes and 3-D objects by:</u></p> <p>Estimating; measuring; recording; comparing and ordering</p> <p><u>Measuring instruments:</u></p> <p>Rulers; metre sticks; tape measures; trundle wheels</p> <p><u>Units:</u></p> <p>Millimetres (mm); centimetres (cm); metres (m); kilometres (km)</p> <p><u>Solve problems in contexts involving length</u></p>			<p>Not a distinct strand in Senior Phase</p>		
<p>Conversions include converting between</p> <ul style="list-style-type: none"> - mm and cm - cm and m - m and km 	<p>Conversions include converting between any of the following:</p> <ul style="list-style-type: none"> - mm; cm; m; km 				

Conversions limited to whole numbers and common fractions	Conversions should include common fractions and decimal fractions to 2 decimal places
---	---



Adapted from DBE (2011b) and DBE (2011c)

PERIMETER AND AREA OF 2D SHAPES					
GRADE 4	GRADE 5	GRADE 6	GRADE 7	GRADE 8	GRADE 9
Measure perimeter using rulers or measuring tapes			Use appropriate formulae to calculate perimeter and area of: Squares; rectangles; triangles	Use appropriate formulae to calculate perimeter and area of: Squares; rectangles; triangles <u>and circles</u>	Use appropriate formulae and conversions between SI units to solve problems and calculate the perimeter of: Polygons and circles
Find areas of regular and irregular shapes by counting squares on grids in order to develop an understanding of square units					
NO WORK WITH GENERAL RULES/FORMULAE FOR CALCULATION OF AREA		Develop rules for calculating the areas of squares and rectangles Investigate the relationship between perimeter and area of rectangles and squares			
				Calculate the areas of polygons, to at least 2 decimal places, by decomposing them into triangles and/or rectangles Use and describe the relationship between the radius, diameter	Investigate how doubling any or all of the dimensions of a 2D figure affects its perimeter and its area

		<p>and circumference of a circle in calculations</p> <p>Use and describe the relationship between the radius and area of a circle in calculations</p>	
	<p><u>Calculations and solving problems:</u></p> <p>Solve problems involving the perimeter and area of polygons (to at least 1 decimal place)</p> <p>Use and convert between appropriate SI units: mm² and cm² and between cm² and m²</p>		<p><u>Calculations and solving problems:</u></p> <p>Solve problems involving the perimeter and area of polygons and circles (to at least 2 decimal places)</p> <p>Use and convert between appropriate SI units: mm², cm², m² and km²</p> <p>Use and describe the meaning of the irrational number Pi (π) in calculations involving circles</p>

Adapted from DBE (2011b) and DBE (2011c)

SURFACE AREA AND VOLUME					
GRADE 4	GRADE 5	GRADE 6	GRADE 7	GRADE 8	GRADE 9
Find volume/capacity of objects by packing or filling them in order to develop an understanding of cubic units					
		Develop an understanding of why the <u>volume</u> of rectangular prisms is given by the length multiplied by the width multiplied by height	Use appropriate formulae to calculate the surface area, volume and capacity of: - Cubes - Rectangular prisms	Use appropriate formulae to calculate the surface area, volume and capacity of: - Cubes - Rectangular prisms and triangular prisms	Use appropriate formulae to calculate the surface area, volume and capacity of: - Cubes - Rectangular prisms - Triangular prisms - Cylinders
		Investigate the relationship between surface area and volume of rectangular prisms	Describe the relationship between surface area and volume of the objects mentioned above		Investigate how doubling any or all of the dimensions of right prisms and cylinders affects their volume

Adapted from DBE (2011b) and DBE (2011c)

APPENDIX G

Curriculum Progression of Measurement Learning (FET Phase Maths, Math Lit & Technical Maths)

MATHEMATICS			MATHEMATICAL LITERACY			TECHNICAL MATHEMATICS
GRADE 10	GRADE 11	GRADE 12	GRADE 10	GRADE 11	GRADE 12	GRADE 10 - 12
Measurement disappears as a separate topic in the FET phase, and becomes part of the study of Geometry and Trigonometry			A separate topic weighted at 15 – 25% in terms of teaching time allocation and mark allocation in summative assessments			A separate topic weighted at 10%
<ul style="list-style-type: none"> - Revise the volume and surface areas of right-prisms and cylinders - Study the effect on volume and surface area when multiplying any dimension by a constant factor k - Calculate the volume and surface areas of spheres, right pyramids & cones 	Revise Grade 10 work <u>Applied in:</u> trigonometry, analytical geometry, Euclidean geometry	Revise Grade 10 work <u>Applied in:</u> trigonometry, analytical geometry, Euclidean geometry as well as practical problems involving optimisation and rates of change in differential calculus	Simple tasks in the familiar context of the household, involving: Conversions Measuring length Measuring weight Measuring volume Temperature Calculating perimeter, area and volume Time	Larger projects in familiar contexts of the household, school and wider community involving: Conversions Measuring length Measuring weight Measuring volume Temperature Calculating perimeter, area and volume Time	Complex projects in familiar and unfamiliar contexts, involving: Conversions Measuring length Measuring weight Measuring volume Temperature Calculating perimeter, area and volume Time	<u>GRADE 10:</u> Conversion of units, square units and cubic units <u>GRADE 11:</u> Solve problems involving volume and surface area of solids studies in earlier grades (i.e. Grade 9) and combinations of those objects <u>GRADE 12:</u> Revise Grade 10 & 11 work

adapted from DBE (2011a; 2011d; 2014b)

APPENDIX H

Curriculum Progression of Measurement Learning (FET Phase Math Lit)

MATHEMATICAL LITERACY		
GRADE 10	GRADE 11	GRADE 12
CONVERSIONS		
Convert units of measurement from memory for: - SI units - time Convert units of measurement using given conversion factors and/or tables for cooking conversions (e.g. cup – ml)		As for Grades 10 & 11 and: Convert between different systems - metric to imperial - solid to liquid - Celsius to Fahrenheit
Express measurement values and quantities in units appropriate to the context		

LENGTH/DISTANCE

Determine length/distance using appropriate measuring instruments, including:

- rulers; measuring tapes; trundle wheels; odometers; maps; scales

Estimate lengths

Calculate values using formulae involving length (e.g. perimeter, area and volume)

Calculate actual length and distance when map and/or plan measurements are known

Estimate distances using measurement and a given scale

Calculate the time taken to complete a journey

Calculate speed

Calculate map and/or plan measurements when actual lengths and distances are known using a given scale to inform the drawing of 2-dimensional plans and the construction of 3-dimensional models

MATHEMATICAL LITERACY		
GRADE 10	GRADE 11	GRADE 12
AREA AND PERIMETER		
Calculate/measure the perimeter and area (including surface area) by: - direct measurement using, e.g. rulers, grids etc. - calculation for: rectangles, triangles and circles (quarter, semi and three quarter) using known formulae		As for Grade 10 and 11 and: Calculation for objects that can be decomposed into rectangles, triangles and circles (quarter, semi and three quarter) using known formulae
Focus is on working with 2-dimensional shapes and calculations of perimeter and area of such shapes	As for Grade 10, but now includes 3-dimensional shapes, with calculations of perimeter and surface area	
When working with plans, determine quantities of materials required by using perimeter and area calculations		

adapted from DBE (2011a)

MATHEMATICAL LITERACY		
GRADE 10	GRADE 11	GRADE 12
VOLUME		
Determine volume using appropriate measuring instruments, including: - measuring spoons/cups/jugs/bottles/buckets/wheelbarrows Measure out quantities to complete a task		
Grade 10 learners are NOT expected to have to perform calculations of volume using appropriate formulae, emphasis must be placed on understanding the concept of volume	Calculate volume using known formulae for rectangular prisms and cylinders Calculate values using a formula involving volume	
When working with plans, determine quantities of materials required by using volume calculations		
Investigate packaging arrangements using <i>actual</i> cans and <i>actual</i> boxes to determine optimal use of space	Make and use 3-dimensional scale models of packaging containers and 2-dimensional diagrams of 3-dimensional models of packaging containers in order to: - determine optimal use of space - estimate quantities of materials required	
		Make and use 3-dimensional scale models of buildings and 2-dimensional scale diagrams of appropriate views of buildings in order to: - critique aspects of the layout and/or design - estimate quantities of materials required

adapted from DBE (2011a)

APPENDIX I

Measurement Learning in NC(V) Mathematics Level 2 And NC(V) Engineering Technology Level 2

MEASUREMENT LEARNING IN NC(V) LEVEL 2 ENGINEERING PROGRAMMES	
NC(V) L2 MATHEMATICS	NC(V) L2 ENGINEERING TECHNOLOGY
<p><u>TOPIC 3: MEASUREMENT</u></p> <p><u>Subject Outcome 3.1:</u> Measure physical quantities</p> <p>Students are able to:</p> <ul style="list-style-type: none"> - read scales on measuring instruments correctly. Instruments include rulers and protractors 	<p><u>TOPIC 4: ENGINEERING PRECISION MEASURING EQUIPMENT</u></p> <p><u>Subject Outcome 4.2:</u> Use precision measuring equipment</p> <p>Students are able to:</p> <ul style="list-style-type: none"> - demonstrate the use of engineering precision measuring equipment
<p>Students are able to:</p> <ul style="list-style-type: none"> - use symbols and SI units as appropriate to the situation 	<p><u>TOPIC 5: SI UNITS OF MEASUREMENT</u></p> <p><u>Subject Outcome 5.1:</u> Demonstrate knowledge of basic SI units of measurement</p> <p>Students are able to:</p> <ul style="list-style-type: none"> - identify basic units of measurement used in science engineering - define the physical quantities that are measured by the SI units <p><u>Subject Outcome 5.2:</u> Convert between SI units</p> <ul style="list-style-type: none"> - perform conversions according to relevant digital values - derive new units from the relationship between the SI units (i.e. the quantities they measure)

APPLICATION OF MEASUREMENT LEARNING

<p><u>Subject Outcome 3.2</u>: Calculate perimeter, surface area and volume in two and three dimensional geometric shapes</p> <p>Students are able to:</p> <ul style="list-style-type: none"> - Calculate the perimeter and surface area of the following laminae: Square; rectangle; circle; triangle; parallelogram; trapezium; hexagons - Calculate the volume and surface area of the following objects: Cubes; rectangular prisms; cylinders; triangular prisms; hexagonal prisms - Investigate the effect on area of laminae where one or more dimensions are multiplied by a constant factor k - Investigate the effect on the volume and surface area of right prisms where one or more dimensions are multiplied by a constant factor k 	<p>Measurement learning is applied:</p> <ul style="list-style-type: none"> - When using precision measuring equipment (Subject Outcome 4.2), including deciding on the best precision measuring equipment for the task (Subject Outcome 4.1) - When using engineering marking off equipment (Subject Outcome 6.2) - When interpreting and understanding basic engineering drawings (Subject Outcome 7.1); applying basic engineering drawing practices (Subject Outcome 7.2); and producing drawings in two-dimensional views (Subject Outcome 7.3) <p>*In addition, measurement is used in practicals in Automotive Repair and Maintenance (DHET, 2013d); Fitting and Turning (DHET, 2013e); and Welding (2013f).</p>
--	---

adapted from DHET (2011) and DHET (2012b)

APPENDIX J

Mediated measurement interaction model

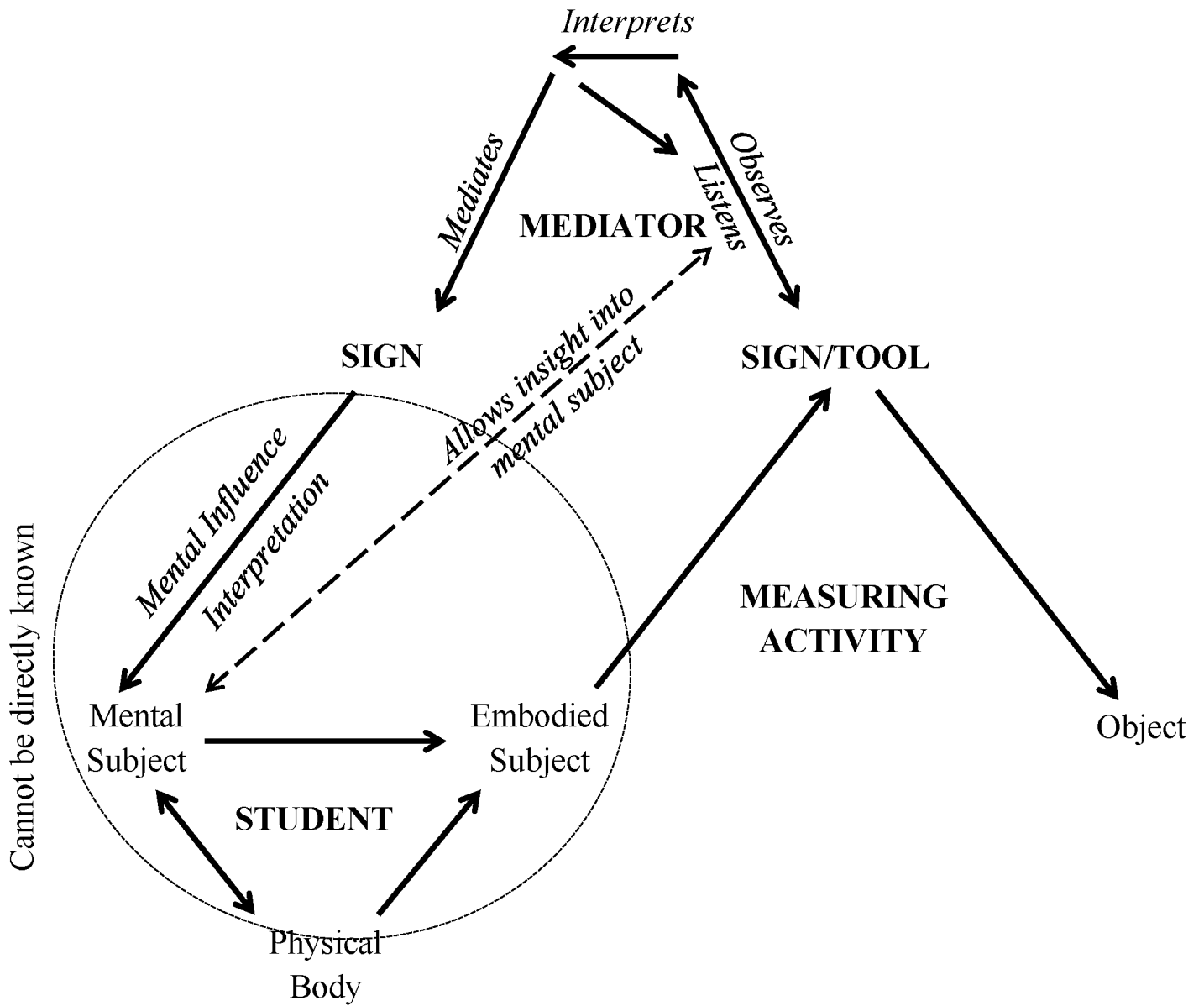

APPENDIX K

Summary of Research Approach

Research position	<p>Interpretivism</p> <p>“[A]n umbrella term used to describe studies that endeavour to understand a community in terms of the actions and interactions of the participants” (Tobin, 2000, p. 487)</p>
Paradigm	<p>Constructivism</p> <p>“[T]he learner is not a passive recipient of knowledge but that knowledge is constructed by the learner in some way” (Rowlands & Carson, 2001, p. 1)</p> <ul style="list-style-type: none"> • Individual psychology The research is concerned with “how the individual learner constructs knowledge in his/her own cognitive apparatus” (Phillips, 1995, p. 7). • Individual cognition The activity of knowledge construction is “described in terms of individual cognition” (Phillips, 1995, p. 8) • Knowledge as human creation The construction of knowledge is a process that is “influenced...by the minds or creative intelligence of the knower or knowers” (Phillips, 1995, p. 7).
Ontology	<p>Realism</p> <p>The realist ontological view that there is a real world does not preclude the claim that knowledge is constructed (Maton, 2014)</p>
Epistemology	<p>Constructivist</p> <p>“[E]ach individual mentally constructs the world of experience through cognitive processes...the world cannot be known directly, but rather by the construction imposed on it by the mind” (Young & Collin, 2004, p. 375)</p>

Methodology	<p>Interpretivist</p> <p>Interpretivist methodologies “focus on the meanings attributed to events, places, behaviours and interactions, people, and artefacts” (Schensul, 2008, p. 517).</p>
Approach	<p>Qualitative</p> <p>Qualitative research is “a situated activity that locates the observer in the world. It consists of a set of interpretive, material practices that make the world visible” (Denzin and Lincoln, 2005, p. 3).</p>
Nature	<p>Exploratory</p> <p>Exploratory research is designed to take an “open, flexible and inductive approach” (Durrheim, 2006, p. 41) in attempting to maximise the discovery of new insight.</p>
Method	<p>Collective case study</p> <p>“Multiple cases are described and compared to provide insight” (Cresswell, 2011, p. 465)</p>
Position of the researcher	<p>Participant/observer</p> <p>Non-participant observation</p>

APPENDIX L

Basic Student Demographic Information

Name	Male/ Female	Year of Birth	Highest Grade Passed (including subject)	Type of School/School Quintile*
Sam	F	1994	Grade 12 (2012) – Math	Q3
Errol	M	1995	Grade 12 (2013) – MLit	Q3
Sanele	F	1990	Grade 12 (2010) – MLit	Q4
Phumzile	F	1994	Grade 12 (2012) – Math	Q2
Siphelele	M	1991	Grade 12 (2009) – Math	Q3
Andile	M	1997	Grade 9 (2013) – Math	Independent School (Q4)
Thandiwe	F	1994	NC(V) Level 2 (2013) – MLit	TVET College – Urban area (equivalent to Q3 – no fee)
Mbulelo	M	1994	Grade 12 (2012) – Math	Q3
Ntando	M	1996	Grade 10 (2013) – Technical Mathematics	Q3 - Special Needs School [Mild and Moderately Handicapped]
Tshawe	M	1994	Grade 12 (2013) – MLit	Q3
Kaden	F	1993	Grade 12 (2012) – MLit	Q3 - Special Needs School [Behavioural]
Luvuyo	M	1994	Grade 12 (2013) – MLit	Q2
Malume	M	1981	Grade 11 (1997) – Math	Q2
Andiswa	F	1994	Grade 12 (2012) – MLit	Q2
Lwazi	M	1992	Grade 12 (2010) – Math	Q3
Neliswa	F	1989	Grade 12 (2007) – Math	Q3
Zukisa	F	1995	Grade 9 (2012) – Math	Q2
Mzwakhe	M	1989	ABET Level 4 (2013) – Mathematics & Mathematical Sciences	Q1 (school); Adult centre for physically disabled and disadvantaged impoverished persons (ABET Level 4; Q1)
Siyabulela	M	1992	Grade 11 (2011) – Math	Q3
Mkhuseli	M	1986	Grade 12 (2004) – Math	Q3
Babalwa	F	1993	Grade 12 (2011) – MLit	Q3
Linda	F	1992	Grade 12 (2010) – MLit	Q3
Aviwe	M	1995	Grade 12 (2013) – Math	Q3
Bonelwa	F	1994	Grade 12 (2012) – Math	Q3
Lindiwe	F	1996	Grade 12 (2013) – Math	Q3
Mthobeli	M	1993	Grade 12(2009) – Math	Q3
Samkelo	M	1994	Grade 12 (2011) – MLit	Q3
Nobuhle	F	1995	Grade 12 (2013) – Math	Q3
Liana	F	1995	Grade 12 (2013) – Math	Q3
Sisipho	F	1992	Grade 12 (2010) – MLit	Q3
Lumko	F	1991	Grade 12 (2009) – Math	Q3
Langa	M	1994	Grade 11 (2011) – Math	Q3
Ndileka	F	1994	Grade 9 (2010) – Math	Q3
Mandisa	F	1994	Grade 11 (2012) – Math	Q3
Malusi	M	1992	Grade 11 (2009) – Math	Q2
Anathi	M	1991	Grade 10 (2007) – Math	Q3

Nomsa	F	1993	Grade 11 (2010) – Math	Q2
Sandla	M	1994	Grade 11 (2011) – Math	Q3
Sandile	M	1991	Grade 10 (2007) – Math	Q3

*School quintile rankings have been extracted from the latest available rankings published by the DBE (2015a; 2015b)

APPENDIX M

Tasks completed by each student

Name	Task 1	Task 2	Task 3	Task 4	Task 5
Sam					
Errol					
Sanele					
Phumzile					
Siphelele					
Andile					
Thandiwe					
Mbulelo					
Ntando					
Tshawe					
Kaden					
Luvuyo					
Malume					
Andiswa					
Lwazi					
Neliswa					
Zukisa					
Mzwakhe					
Siyabulela					
Mkhuseli					
Babalwa					
Linda					
Aviwe					
Bonelwa					
Lindiwe					
Mthobeli					
Samkelo					
Nobuhle					
Liana					
Sisipho					
Lumko					
Langa					
Ndileka					
Mandisa					
Malusi					
Anathi					
Nomsa					
Sandla					
Sandile					

*each grey block indicates a task completed

APPENDIX N

Levels of Mediation

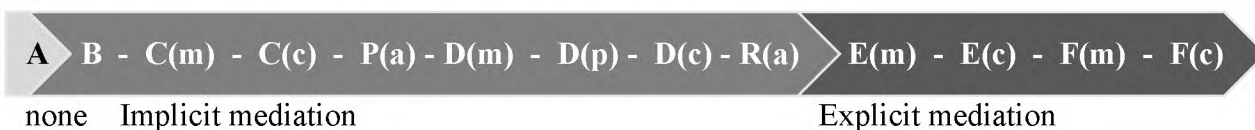

*(m) – method; (c) – concept; (a) – artefact

These codes refer to the following:

- A: no mediation
- B: reassurance
e.g. ‘go on...’
- C(m): prompt (method)
e.g. ‘and the value is...’ at the end of Task 4 to prompt students to realise they were to calculate the cost of building and not only the area
- C(c): prompt (conceptual)
e.g. stating ‘perpendicular’ during Task 4 when struggling to decide where to place their ruler to measure the height of the triangle
- P(a): provision of an additional artefact
e.g. providing an extra unit tile or unit cube [Tasks 1 & 2]
- D(m): leading question (method)
e.g. how do you calculate the area of a triangle? [Task 4]
- D(p): leading question (process)
e.g. Asking ‘what do you need to do next to get the area of the whole shape?’ when students did not know how to proceed after finding the areas of regions of a composite rectangle [Task 4]
- D(c): leading question (conceptual)
e.g. Asking ‘what shapes combine to form this hexagon?’ [Task 4]
- R(a): reference made to artefact
e.g. wordlessly pointing to the line whose measurement is required in order to calculate the area of a shape [Task 4]
- E(m): instruction (method)
e.g. providing the required formula if a student cannot recall it
- E(c): instruction (conceptual)
e.g. explaining the concept of volume during a task requiring the measurement or calculation of volume [Task 1]
- F(m): correction (method)
e.g. providing assistance in correcting a calculation error made when calculating area
- F(c): correction (conceptual)
e.g. providing assistance when an error has been made as a result of inaccurate or as yet emerging conceptualisation of measurement domain

APPENDIX O

Consent Document

You are invited to participate in a research study conducted by Pamela Vale, from the Department of Education at Rhodes University. I hope to learn about what knowledge Level 2 Engineering students have regarding measurement when they enter the Engineering courses. You were selected as a possible participant in this study.

Any information that is obtained in connection with this study and that can be identified with you will remain confidential and will be disclosed only with your permission. Your identity will be kept confidential. To begin with I will be storing your information according to your student number and not your name. Because it is possible to look up your name if I have your student number, as soon as we have completed the interviews I will assign you a code that will only be known to me. The data will be stored securely and will not be accessible to anyone except myself. You will be completely anonymous in any reports made of the data.

Your participation is voluntary. Your decision whether or not to participate will not affect your relationship with XXXX TVET College, Rhodes University, your college lecturers or myself. If you decide to participate, you are free to withdraw your consent and discontinue participation at any time without penalty.

Your signature indicates that you have read and understand the information provided above and willingly agree to participate.

Name: _____

Signature

Date: _____

My signature below indicates that I, Pamela Vale, commit to uphold all of the conditions outlined in the invitation letter above.

Signature

APPENDIX P

Map of Holiday Resort



APPENDIX Q

Formal Written Test

[Note: The text contained in this appendix is reproduced exactly as it appeared in the formal written test.]

QUESTION 1

Marc, a scientific officer designed an apparatus for an experiment. This apparatus has a rectangular block as a base with a regular hexagonal prism mounted on top of the rectangular block. A hole with a diameter of 20mm is drilled through both the hexagonal prism and the rectangular block.

- 1.1 Determine the volume of (a) the hexagonal prism and the volume of (b) the rectangular block before the hole is drilled.

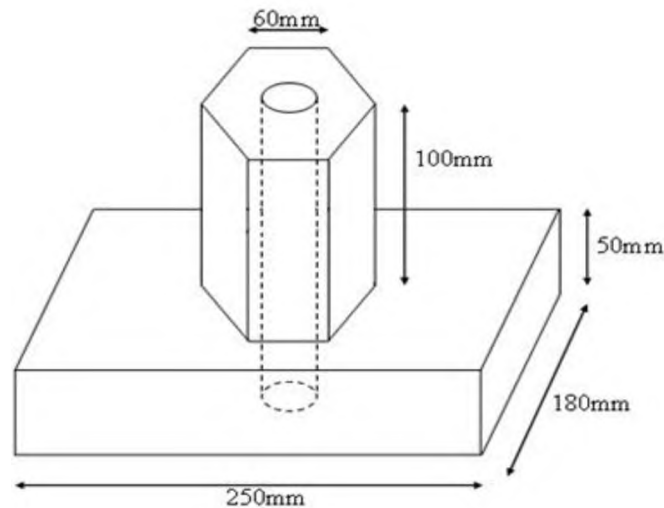

- 1.2 Determine the volume of the hole (cutting).
- 1.3 Determine the volume of the apparatus.

QUESTION 2

- 2.1 The manufacturing company you work for has a contract to make coffee tins for a new coffee supply. The tin is in the shape of a cylinder with a perpendicular height of 24cm and a volume of 2000cm^3 . You are the IT technician responsible for programming the laser cutter, which will cut circular sheets for each tin base.

2.1.1 Calculate the radius.

2.1.2 The base area of the cylinder, to three decimal places.



2.2 An athletics track consists of two semi-circular bends of diameter 45 metres each and two straight sides of 180 metres each.

Calculate the total distance that an athlete will cover on this track.

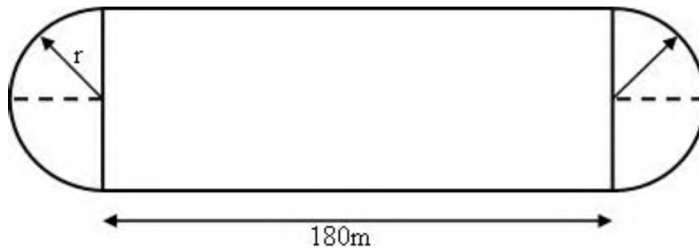

2.3 A farmer wants to cover a rectangular stack of hay 6m wide, 20m long and 11m high with plastic.

Calculate the total surface area of the haystack to determine the minimum amount of plastic needed (NB, the whole stack including the base, must be covered).

QUESTION 3

Calculate (a) the volume and (b) the total surface area for shapes 3.1, 3.2, 3.3 and 3.4 below:

3.1

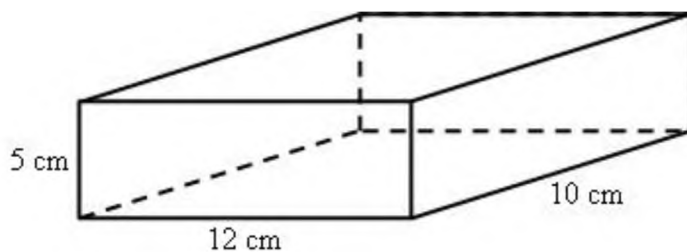

3.2

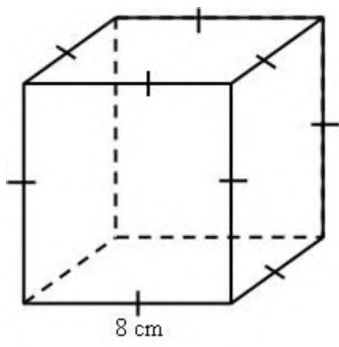

3.3

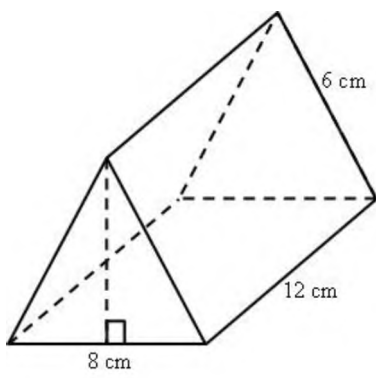

3.4

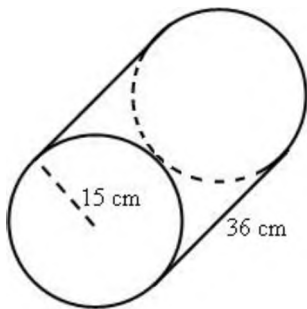

APPENDIX R

Formula Sheet

$$1) A_{\text{square}} = l \times l = l^2$$

$$2) A_{\text{rectangle}} = l \times w$$

$$3) A_{\text{triangle}} = \frac{1}{2} b \times h$$

$$4) A_{\text{circle}} = \pi r^2$$

$$5) C = 2\pi r$$

6) Area of parallelogram = base \times perpendicular height

$$7) A_{\text{hexagon}} = \frac{3\sqrt{3}}{2} L^2$$

$$8) A_{\text{hexagon}} = \frac{\sqrt{3}}{2} W^2$$

$$9) A_{\text{cylinder}} = 2\pi r(h + r)$$

10) Volume = Area of base \times perpendicular height

11) Total surface area of a triangular prism = (height of prism \times perimeter of base) + 2 (area of base)

$$12) m = \frac{\Delta y}{\Delta x} = \frac{y_2 - y_1}{x_2 - x_1}$$

$$13) D = \sqrt{(x_2 - x_1)^2 + (y_2 - y_1)^2}$$

$$14) M = \left(\frac{x_1 + x_2}{2}, \frac{y_1 + y_2}{2} \right)$$

$$15) \theta = \tan^{-1} m$$

$$16) \bar{x} = \frac{\sum_{i=1}^n x_i}{n} \quad \text{or} \quad \text{Mean} = \frac{\text{total or sum of all items}}{\text{number of items}}$$

$$17) R = X_n - X_1 \quad \text{or} \quad \text{Range} = \text{highest value} - \text{lowest value}$$

APPENDIX S

Scans of work from Task 1

1. NTANDO

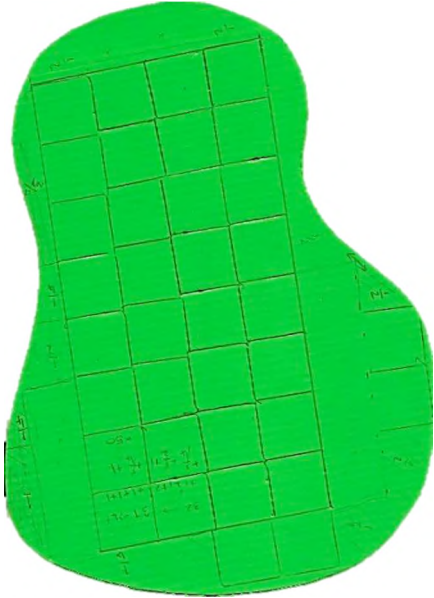

2. KADEN



3. MZWAKHE

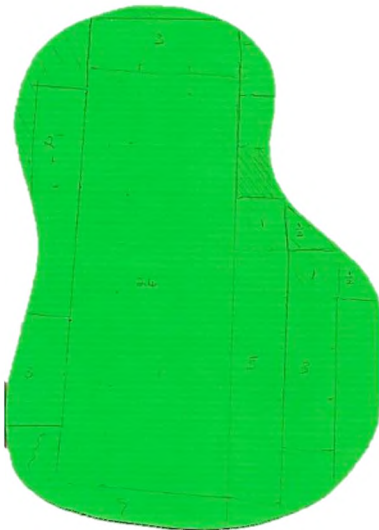

4. NELISWA

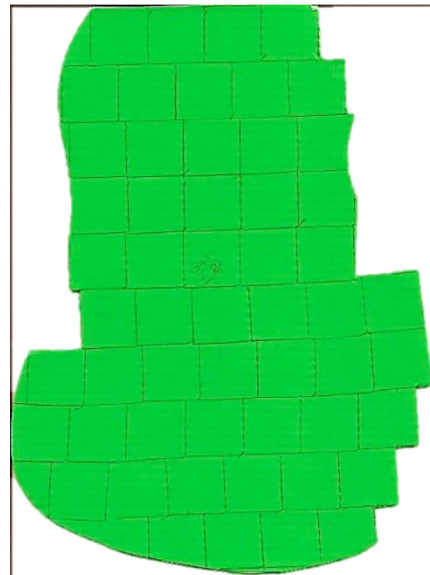

5. NOBUHLE

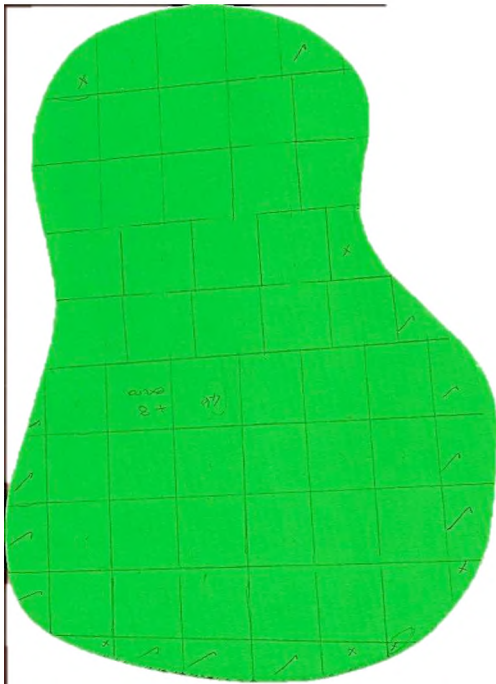

6. AVIWE

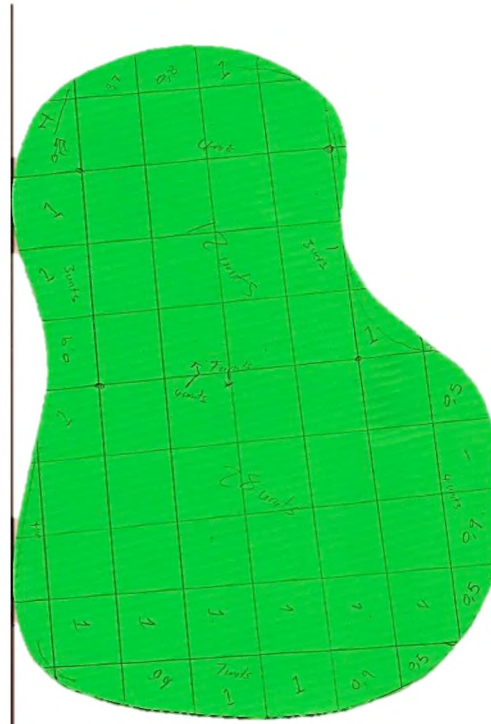

7. SISIPHO

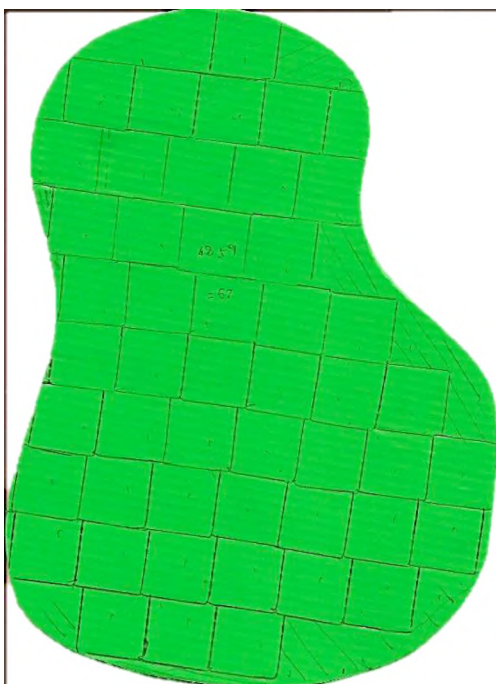

8. MALUSI

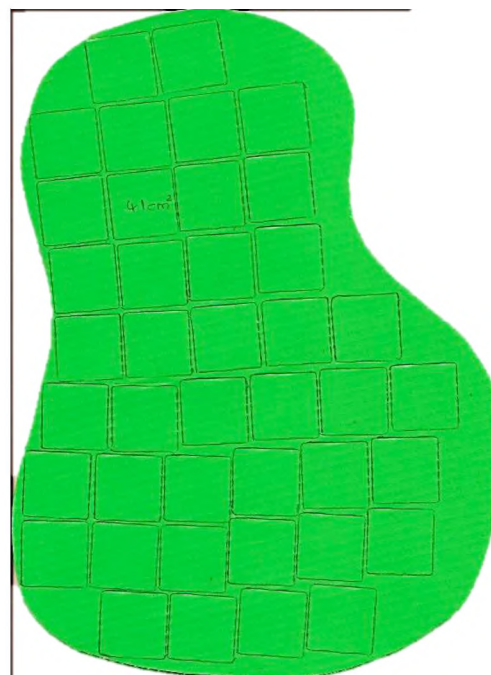

9. NDILEKA

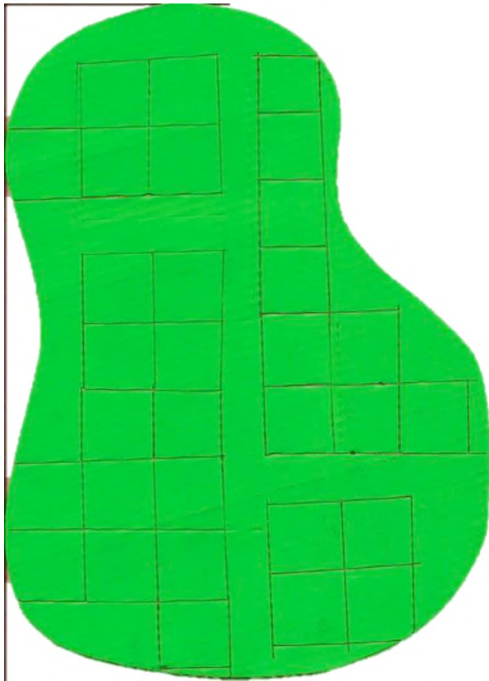

10. SANDLA

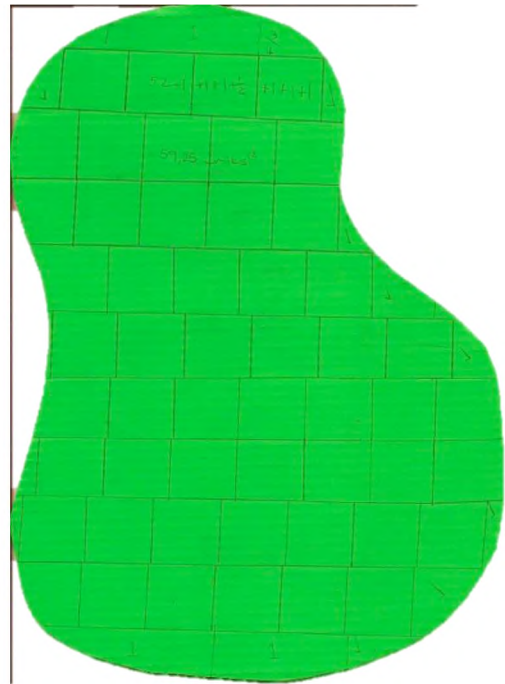

11. ERROL

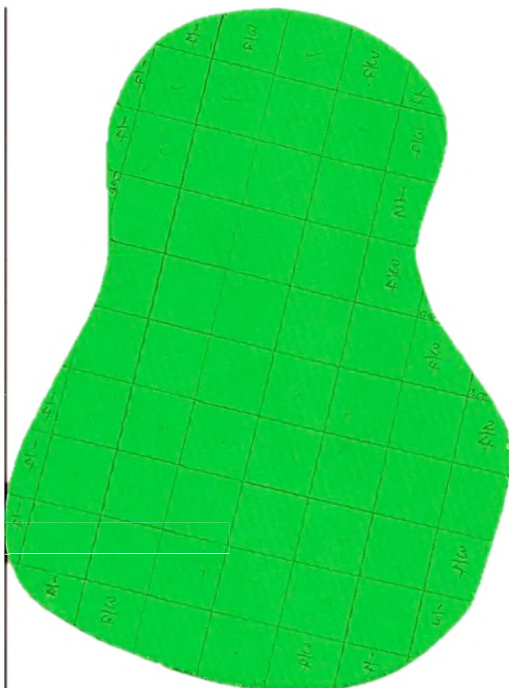

12. PHUMZILE

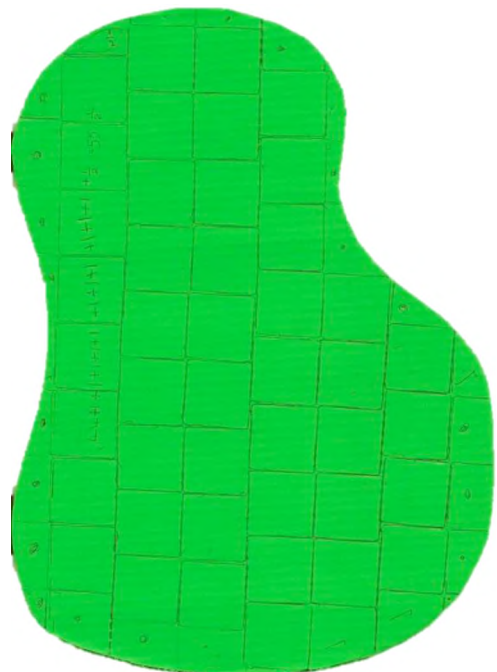

13. ANDISWA

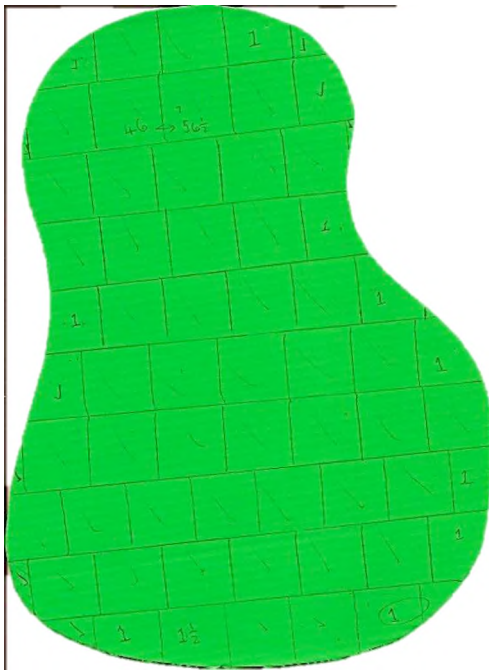

14. MKHUSELI

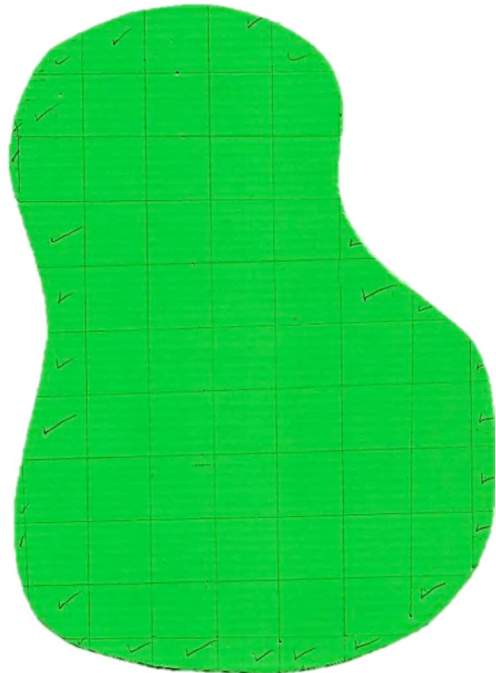

15. BABALWA

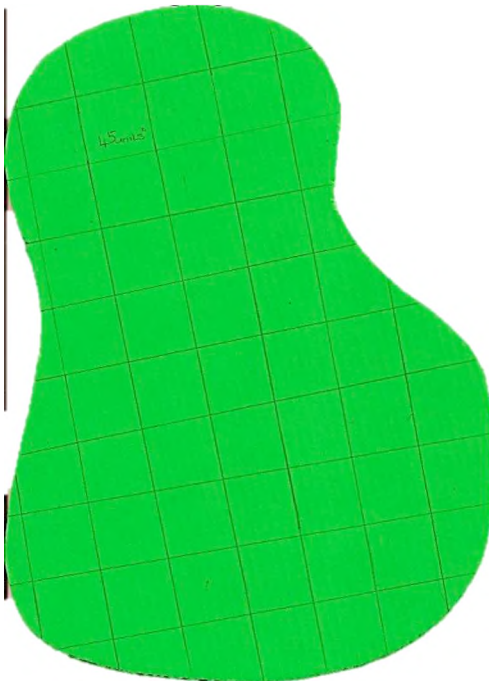

16. SAMKELO

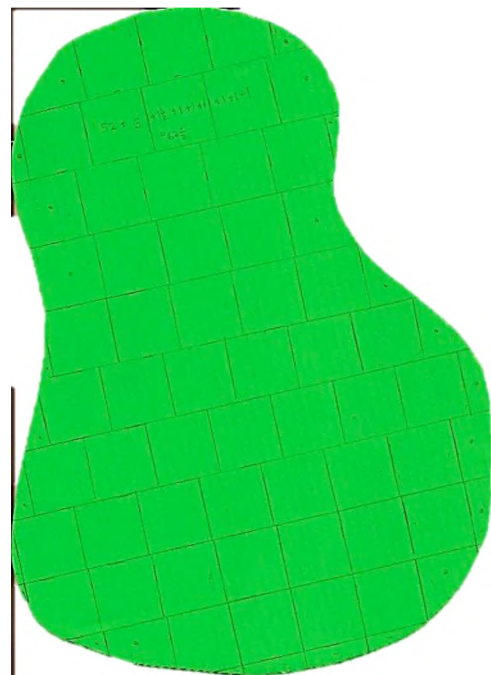

17. ANDILE

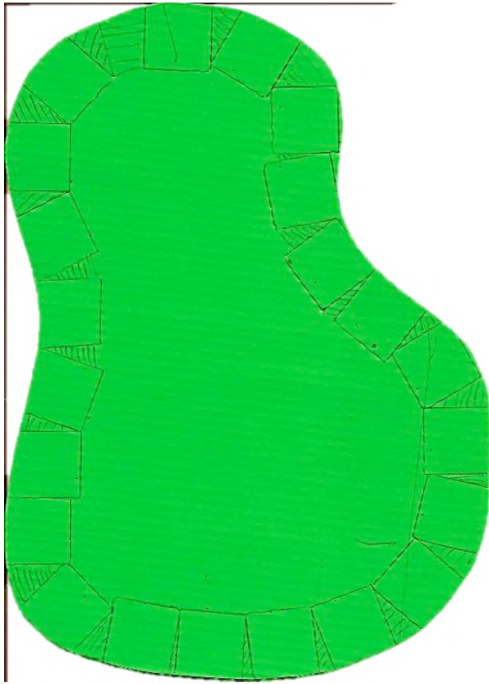

18. SANELE

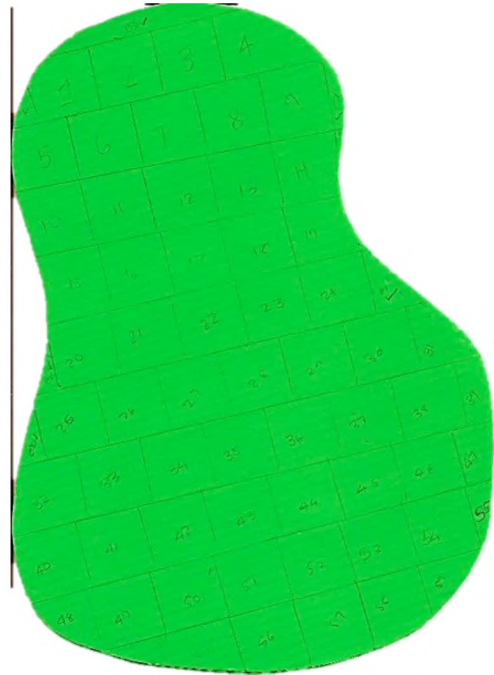

19. THANDIWE

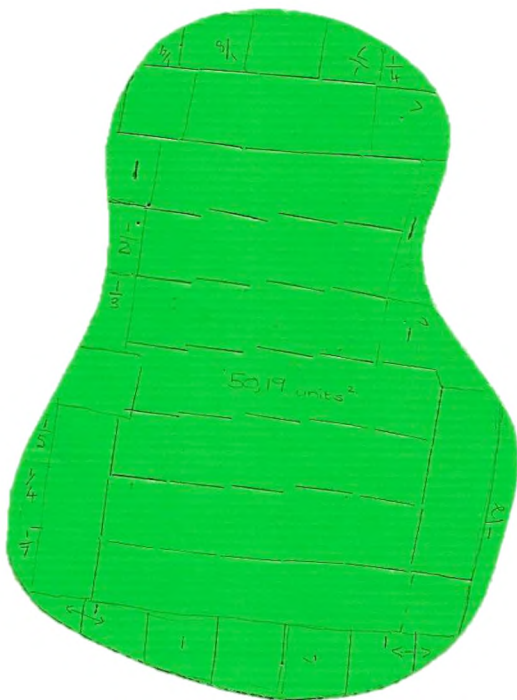

20. LINDA

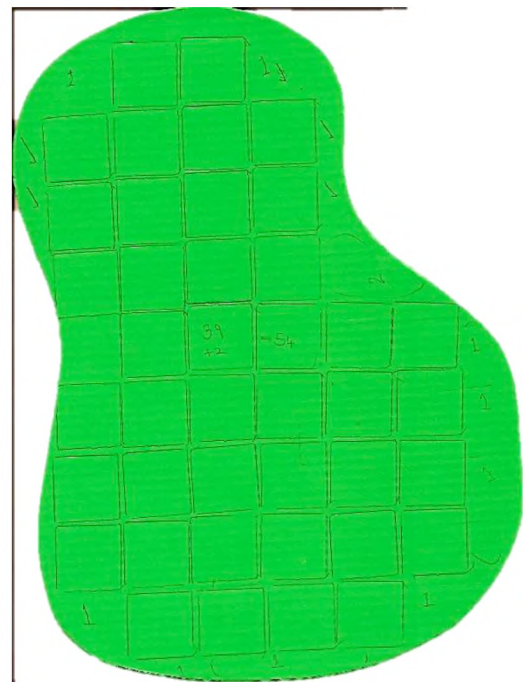

25. MBULELO

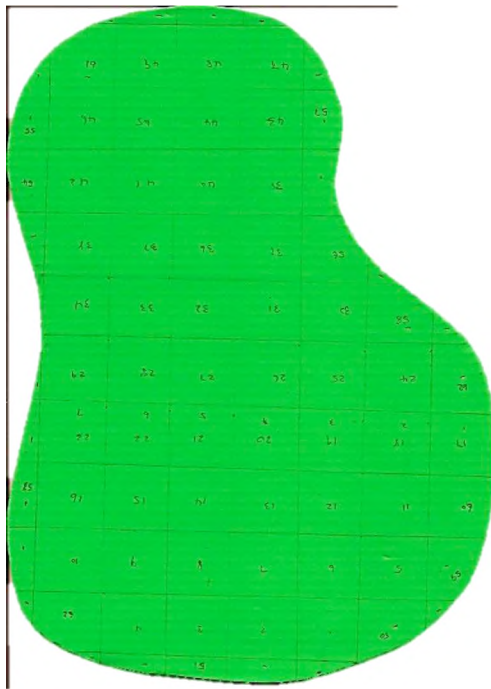

26. LANGA

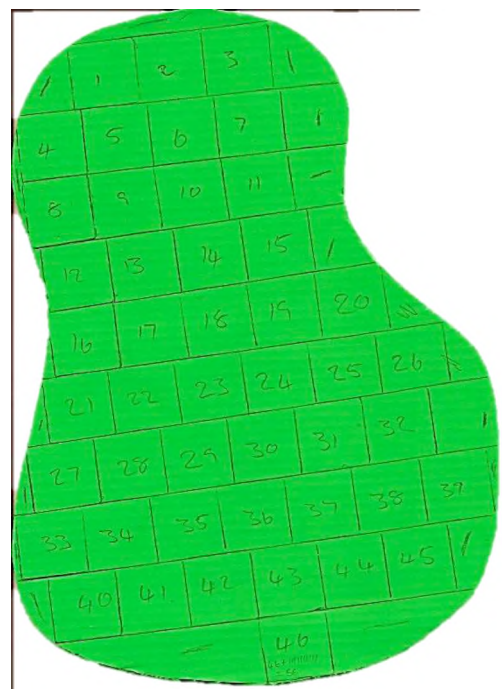

27. NOMSA

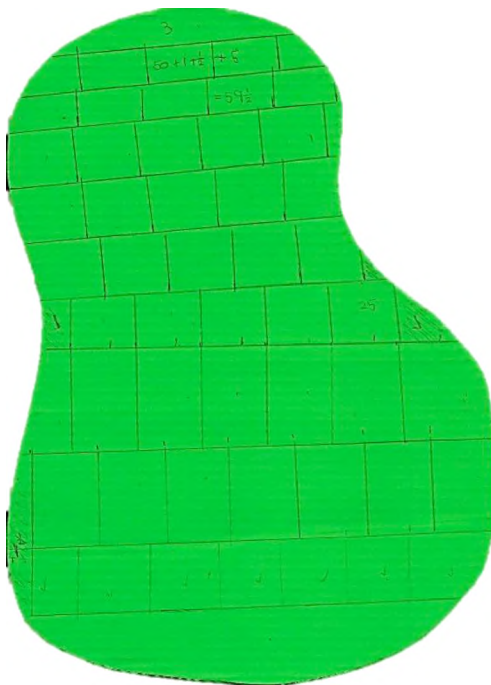

APPENDIX T

Summary of performance on Task 1

STUDENT	PHASE 1		PHASE 2		PHASE 3
	STRATEGY	MEDIATION	STRATEGY	MEDIATION	
Ntando	RA	B	LR	E(m); C(m); B; D(m); B; B	E(m); E(m)
Kaden	IP	F(c); C(m)	CW*	D(p)	C(m); F(c)
Mzwakhe	RD	C(m)	LR	D(p); D(m); F(m); F(c); E(c)*; D(m)*; D(m)*	E(m)*; F(c)
Neliswa	IR	A	CW	D(p); B	A
Nobuhle	RA	D(m); B	EA→CW	A	F(m)
Aviwe	RA	D(c)	EA→LD	A	A
Sisipho	IR	B	PW	D(p); F(c)*	F(c)
Malusi	IR	A	PW	D(p); F(c)*	F(c)*
Ndileka	RA	B; C(c); D(c); E(m); E(c); P(a); C(c)	none	F(c); F(c)*	Abandoned
Sandla	IR	A	LR	D(p); F(c)*; F(c)*	A
Errol	RA	A	EA→LR	D(c)	C(m); E(m)*
Phumzile	IR	A	CW*	D(m); D(c); E(m)*	A
Andiswa	IR	A	CW*	D(p)	A
Mkhuseli	RA	A	EA→CW	D(p)	A
Babalwa	RA	A	EA→CW	E(m)	E(m)*
Samkelo	IR	A	EA→CW*	D(p)	A
Andile	IP	D(m)	LR	D(p); D(c); D(c)	Incomplete
Sanele	IR	B	EA→CW	D(p)	A
Thandiwe	IR	D(c); B	LR	D(p); E(c)*	E(m)*
Linda	RA	A	CW	D(p)	A
Malume	RD	C(m); D(c)	RD→LR	D(p); C(m); F(c)*	A
Sam	RA	B	LR	D(p); B; B; F(c)*	F(c)*
Mthobeli	RA	D(c)	CW	D(p)	A
Siphelele	Other	D(c); E(m)	EA→LD	D(p)	Incomplete
Mbulelo	RA	A	EA→CW	A	A
Langa	IR	A	CW*	D(p); C(m)*	A
Nomsa	IR	E(m)	CW*	F(c)	F(c)

APPENDIX U

Summary of performance on Task 2

STUDENT	PHASE 1	PHASE 2	ANSWER
Ntando	D(c)	P(a); B	Correct
Kaden	B	P(a); <i>F(c)[to correct]</i>	Surface Area = 96
Mzwakhe	F(m)	P(a); <i>E(m)[to correct]</i>	Volume = 48
Neliswa	A	P(a); <i>F(c)[to correct]</i>	Surface Area = 64
Nobuhle	A	P(a); <i>F(c)[to correct]</i>	Surface Area = 64
Aviwe	A	A	Correct
Sisipho	A	P(a); <i>F(c)[to correct]</i>	Surface Area = 64
Malusi	E(c); E(c) F(c)	P(a); <i>F(c)[to correct]</i>	Completed together
Ndileka	A	P(a); E(c); <i>F(c)[to correct]</i>	Completed together
Sandla	A	P(a)	Correct
Errol	B; B	P(a); <i>F(c)[to correct]</i>	Surface Area = 96
Phumzile	A	P(a); <i>F(c)[to correct]</i>	Surface Area = 64
Andiswa	D(c)	P(a); D(c); <i>F(c)[to correct]</i>	Surface Area = 64
Mkhuseli	A	P(a)	Correct
Babalwa	A	P(a); D(c); <i>F(c)[to correct]</i>	Surface Area = 64
Samkelo	D(c)	P(a)	Correct
Andile	B	P(a); <i>F(c)[to correct]</i>	Surface Area = 64
Thandiwe	B	P(a); D(c); <i>F(c)[to correct]</i>	Surface Area = 64
Linda	F(c)	P(a); D(c)	Correct
Malume	B	A	Correct
Sam	F(c)	P(a); F(c); D(c); <i>F(c)[to correct]</i>	Surface Area = 64
Mthobeli	A	A	Correct
Siphelele	A	P(a); <i>F(c)[to correct]</i>	Surface Area = 64
Mbulelo	A	A	Correct
Langa	A	P(a); <i>F(c)[to correct]</i>	Surface Area = 64
Nomsa	F(c)	P(a); <i>E(m)[to correct]</i>	Volume = 48

APPENDIX V

Detailed Summary - Task 3, Subtask 1

S – Student

I - Interviewer

	Q1 – What volume flowed out in 10 seconds?	Q2 – What is the flow rate?
Ntando	S: you said we had six? So we can say it's 1, 2, 3, [counting hash marks] and maybe let's say 4 quarters or 3 quarters I: F(c) – was counting hash marks S: two and... oh... 3 quarters... and one third! [help to write correctly, was writing 1/3 instead of $\frac{3}{4}$]	S: I'll have... let's say... um... it's less... is it 2.4 or 2.3? I: E(c) and E(m) S: 0.275units/sec
Kaden	A S: 2 units (in 5 seconds)	A S: 0.4units/sec
Mzwakhe	S: [counts units of volume from the bottom and gets 3.5] I: D(c) – are we measuring the amount that flowed out or the amount that remained? S: 2.5units	S: we divide [10] by... 60 I: C(m) – look what you have written [point at 2.5units] S: 0.25units/sec
Neliswa	A S: 2... 2 and a half	A S: 0.25units/sec
Nobuhle	S: 3 and a half [counted hash marks] I: F(c) S: 2.5	A S: 0.25units/sec
Aviwe	A S: [unhesitant] 2.5	A S: I would say... 0.5 I: D(m) – how did you do to get that?

		<p>S: we are using the time and then took the... passed the... units and tried to get the lower amount possible...</p> <p>I: F(c) – showed on bottle what his answer means</p> <p>S: [now does the correct calculation on calculator] 0.25units/sec</p>
Sisipho	<p>S: 3 and a half [counted hash marks]</p> <p>I: F(c)</p> <p>S: 2.5</p>	<p>A</p> <p>S: 0.25units/sec</p>
Malusi	<p>A</p> <p>S: 3 units</p>	<p>S: [long pause; keys in 3 - 10 on the calculator; then keys in $10 \div 3$ to get 3.3]</p> <p>I: F(c) – show on the bottle how this is impossible</p> <p>S: keys in $3 \div 10$ to get 0.3units/sec</p>
Phumzile	<p>S: 3.4 or 3.5 [reading volume units from bottom]</p> <p>I: D(c) – are we measuring the amount that flowed out or the amount that remained?</p> <p>S: 2.5 units</p>	<p>S: 1 divided by 2.5...so since I want for 1 second, 2.5 is the one that came out, so I'm going to divide one by this 2.5</p> <p>I: D(c) – what about the 10 seconds?</p> <p>S: okay! So I'm going to divide this 10 second... and write: <i>10 divided by 2.5 = 4 seconds</i></p> <p>I: F(c)</p> <p>S: 0.25units/sec</p>
Sandla	<p>S: 3.5 [reading volume units from bottom]</p>	<p>A</p> <p>S: 0.25units/sec</p>

	<p>I: D(c) – are we measuring the amount that flowed out or the amount that remained?</p> <p>S: 2.5 units</p>	
Andiswa	<p>A</p> <p>S: two and a half...2.8</p>	<p>S: 10 divided by 2.8</p> <p>I: E(c)</p> <p>S: 0.28units/sec</p>
Mkhuseli	<p>A</p> <p>S: 2 and a half [counted a few times to check]</p>	<p>S: for five it's going to be ... 1 and a quarter</p> <p>I: D(m) – and for 1 second?</p> <p>S: ...an eighth... half of a quarter [calculating mentally]</p> <p>I: C(m) – give calculator</p> <p>S: 0.25units/sec</p>
Babalwa	<p>S: 3 and a half [counted hash marks]</p> <p>I: F(c)</p> <p>S: 2 and a half</p>	<p>A</p> <p>S: 0.25units/sec</p>
Samkelo	<p>A</p> <p>S: 2 and a half</p>	<p>A</p> <p>S: 0.25units/sec</p>
Andile	<p>A</p> <p>S: 2 and a half</p>	<p>S: I'm thinking 'times'... 2.5×10</p> <p>I: F(c) – show what it means</p> <p>S: 0.25units/sec</p>
Sanele	<p>A</p> <p>S: 2 and a half</p>	<p>S: [10 divided by 2.5] 4</p> <p>I: F(c) – show what it meant</p> <p>S: [still unable to realise the error]</p> <p>I: E(c) – had to work together to get 0.25units/sec</p>
Thandiwe	<p>A</p>	<p>S: I have no idea</p>

	S: 2	I: E(c) – had to work together to get 0.25units/sec
Linda	S: 3 and a half [reading volume units from bottom] I: D(c) – are we measuring the amount that flowed out or the amount that remained? S: 3 and a half [counted hash marks] I: F(c) S: 2 and a half	S: [10 divided by 2.5] 4 I: F(c) – show what it meant S: 0.25units/sec
Malume	*problem with stopwatch (3 sec) S: 1.8 (correctly read)	S: [first did 1.8×3 , then tried 1.8 divided by 3 to get 0.6 but unsure] I: F(c) – show what it meant S: 0.6units/sec [now sure]
Lwazi	S: 3 and a half [counted hash marks] I: F(c) S: 2 and a half	S: [calculates mentally] $\frac{1}{2}$ in 2 seconds [now stuck] I: B S: [calculates mentally] $\frac{1}{4}$ units/sec

APPENDIX W

Detailed Summary - Task 3, Subtask 2

S – Student

I - Interviewer

	PREDICT	Q1 – what is the volume that flows out in 10 seconds?	Q2 – what is the flow rate?
Ntando	S: ...um... the hole is a little bit smaller... I think it would be...um... I think it would be 2 [units] REASONABLE	S: it was 2...2 quarters [counted hash marks again] I: C(c) – reminder S: so it's 1...1 and a half	A S: so there [points at subtask 1] we said 2 comma something, so here it is 1 comma fifty S: 0.15units/sec
Kaden	S: more than one (in 5 seconds) REASONABLE	A S: one	A S: 0.2units/sec
Mzwakhe	S: 1 unit PERFECT	A S: 1	A S: 0.1units/sec
Neliswa	S: I think... 1... 1 unit PERFECT	A S: yes! It's one!	A S: 0.1units/sec
Nobuhle	S: I think it will be 4 or 5 TOO HIGH	A S: one, because this [the hole] is a smaller size	A S: 0.1units/sec
Aviwe	S: 0.5 REASONABLE (less than ST1)	A S: 1 unit	A S: [whispers] a decimal [out loud] 0.1units/sec
Sisipho	S: 1 'cos it's a smaller hole and there isn't very much that is going to come out PERFECT	A S: 1	A S: [first did 1×10 then 1 divided by 10] 0.1units/sec
Malusi	S: 1 PERFECT	A S: 1	A S: 0.1units/sec
Phumzile	S: [did 2.5 divided by 2 = 1.25 on calculator] I think 1.25 because this hole is half of that one [points to bottle from subtask 1] REASONABLE	A S: 1	A S: 0.1units/sec

Sandla	S: maybe...0.5 REASONABLE (less than ST1)	S: 1.9 [counted hash marks] I: C(c) – reminder (had done this correctly previously) S: 1	A S: 0.1units/sec
Andiswa	S: the hole is going to be smaller? I: yes S: less CORRECT	A S: 1.2	A S: 1.2 divided by 10 = 0.12units/sec
Mkhuseli	S: 1 and a half... or 1 PERFECT	A S: 1	A S: [calculated mentally] 0.1units/sec
Babalwa	S: 1 and a half REASONABLE (less than ST1)	S: 2 [counted hash marks] I: C(c) – reminder S: 1	S: 0.5 [calculated mentally]... I tried to divide I: F(c) S: 0.1units/sec
Samkelo	S: About 1 PERFECT	A S: 1	A S: 0.1 units/sec
Andile	S: flow rate will be less CORRECT	S: one and three quarters [counted hash marks] I: C(m) [had done it correctly previously] S: 3 quarters	A S: 0.075units/sec
Sanele	S: 5 units TOO HIGH	A S: 1 unit	A S: 0.1units/sec
Thandiwe	S: 1 or something CORRECT	A S: 1 unit	S: is it 10 divided by 2? I: C(c) – but there is no 2 S: 0.1units/sec
Linda	S: 0.23 units TOO LOW	A S: 1	A S: 0.1units/sec
Malume	*problem with stopwatch (3 sec) S: less CORRECT	A S: 0.6	A S: 0.2units/sec
Lwazi	S: 1 and a half REASONABLE	A S: 1	A S: [calculated mentally] 0.1units/sec

APPENDIX X

Detailed Summary - Task 3, Subtask 3

S – Student

I – Interviewer

	PREDICT (ST3)	Q1 – How long did it take for 4 units to flow out?	Q2 – What is the flow rate?
Ntando	unable	<p>A S: 27 seconds for 4 units I: what did you notice? S: the first time [at the start] we had a little bit of pressure, when it was going down the pressure dropped I: Why do you think? S: the water was getting less and there was less pressure [gestures with both hands pushing together to indicate pressure]</p>	<p>A S: [presses 4 and ÷] how do you calculate again? I: B S: 4 divided by...27! [writes 0.148]</p>
Kaden	S: 0.2 units/sec CLOSE	<p>A S: 50 secs for 5 units S: [as watching, pointing at stream] it slows down. I: why? S: because the water inside...it's...less [gestures with both hands pushing together to indicate pressure]</p>	<p>A S: 0.1units/sec because there are 2 holes...it had not a lot of pressure</p>
Mzwakhe	S: 40 seconds for 4 units REASONABLE (was 10 seconds for 1 unit)	<p>A S: 30 seconds I: What did you notice? S: the streams of water changed I: Why do you think it changed? S: the pressure...too much pressure</p>	<p>A S: 0.13units/sec</p>
Neliswa	unable	<p>A S: 31 seconds</p>	<p>A S: 0.13units/sec</p>
Nobuhle	S: more flow rate...10 seconds INCORRECT; FLOW RATE PREDICTION CORRECT FOR THOSE 10 SECS	<p>A S: 5 units in 45 seconds I: Why is this different to your prediction? S: because the hole is still small I: what happened?</p>	<p>A 0.11units/sec</p>

		<p>S: It was the same [stream out each hole] and then it changed... when it became very low then the two holes couldn't be very fast</p> <p>I: Why?</p> <p>S: because of the volume, the volume became less</p>	
Aviwe	<p>S: [looks very closely!] 5 seconds TOO LOW (TAKING HOLES INTO CONSIDERATION NOT NUMBER OF UNITS)</p>	<p>A</p> <p>S: 30 seconds</p> <p>I: Why was it so different to the prediction?</p> <p>S: [long pause] the size of the hole... the volume of the ... [long pause]... that's it</p>	<p>A</p> <p>S: 0.13units/sec</p>
Sisipho	<p>S: rate should be about same as the first [subtask (0.25units/sec)] ...[on calculator, presses 4 x 0.25]</p> <p>REASONABLE IF ONLY 10 SECS</p>	<p>A</p> <p>S: 30 sec, it slowed down</p> <p>I: What did you notice?</p> <p>S: It was fast and then went slow... it's the water... it's out</p>	<p>A</p> <p>S: it's 4 divided by 30 = 0.13units/sec</p>
Malusi	<p>S: [a long pause] I think it will be 20 seconds</p> <p>DOUBLE TIME FOR ST2 (2 HOLES)</p>	<p>A</p> <p>S: 37 seconds for 5 units</p> <p>I: Why do you think it was more than you predicted?</p> <p>S: I think the pressure is not too much when you have two of them [holes]</p>	<p>A</p> <p>S: 0.14units/sec</p>
Phumzile	<p>S: 4 seconds</p> <p>TOO LOW</p>	<p>A</p> <p>S: 29 seconds</p> <p>I: What did you notice?</p> <p>S: It was coming out very quickly</p> <p>I: Did you notice a change?</p> <p>S: it slowed down</p>	<p>A</p> <p>S: 0.14units/sec</p>
Sandla	<p>S: 15 seconds</p> <p>TOO LOW (longer than ST2)</p>	<p>S: 4 units, 30 seconds</p> <p>I: Describe what happened</p> <p>S: it's coming out fast... then it drops</p> <p>I: why is it different to your prediction?</p> <p>S: ... two holes?</p> <p>I: E(c)</p>	<p>A</p> <p>S: 0.13units/sec</p>
Andiswa	unable	A	<p>A</p> <p>S: 0.13units/sec</p>

		S: 31 secs...there are two holes but they are too slow	
Mkhuseli	<p>S: 2 and a half...it's going to be the same as ... [points at answer to subtask 1 first one]...two holes same as 1 big one</p> <p>Changes his mind...</p> <p>S: I think it's going to be the same as... [points at answer to subtask 1], 10 secs</p> <p>FOCUS ON HOLES NOT VOLUME</p>	<p>A</p> <p>S: 27 secs</p> <p>I: What did you notice?</p> <p>S: Water was coming out slower</p> <p>I: Why?</p> <p>S: It was closer to the hole</p>	<p>A</p> <p>S: [uses calculator ... $27 \div 4 \times \dots$ and then... $4 \div 27 =$] 0.148units/sec</p>
Babalwa	<p>5 sec</p> <p>TOO LOW; HALVED TIME FOR DOUBLE HOLES</p>	<p>A</p> <p>S: 32 sec</p> <p>I: What did you notice?</p> <p>S: Both of them went slower</p> <p>I: Why do you think that happened?</p> <p>S: Force!</p>	<p>S: [tries $32 \div 4$, but self-corrects to $4 \div 32$] 0.125units/sec</p>
Samkelo	<p>S: [looks very closely at bottle pointing at and counting stripes hash marks and gap] 8 units... wait, wait!...[thinking]... I think it will be 20seconds</p> <p>TOO LOW; DOUBLED TIME FOR 2 HOLES</p>	<p>A</p> <p>S: 30 seconds</p> <p>I: What did you notice?</p> <p>S: The flow rate lowers</p> <p>I: What do you think causes that?</p> <p>S: It's the pressure</p>	<p>A</p> <p>S: 0.13units/sec</p> <p>I: Why do you think this answer is so close to the flow rate of subtask 2</p> <p>S: because we changed the volume let out</p>
Andile	<p>S: 75 secs</p> <p>TOO HIGH</p>	<p>A</p> <p>S: 31 sec</p> <p>I: What did you notice?</p> <p>S: it had a lot of pressure and then is starting to stop"</p> <p>I: Why do you think it changed?</p> <p>S: I think it's because the thing was full and pushing</p>	<p>A</p> <p>S: 0.13units/sec</p>
Sanele	S: 5 sec	A	A S: 0.13units/sec

	TOO LOW; HALVED TIME FOR TWO HOLES	S: 30 sec...streams are same, then less I: Why? S: [long pause] because it was faster and then slow, as it was coming down there was less pressure	
Thandiwe	S: 5 seconds, or less than 5 TOO LOW; HALVED TIME FOR TWO HOLES	A S: 45 seconds [5 units], the stream decreases I: Why? S: because when it starts here... [points at top of bottle] it's coming out faster and then when it comes here [points at bottom of bottle] it's slower I: Why? S: because of the force	A S: 0.1units/sec
Linda	S: 20 ... there's 2 holes? I: yes S: then 8 TOO LOW; DECREASED TIME FOR TWO HOLES	A S: 32 seconds I: Why do you think it was longer than predicted? S: the holes are small... there were 4 units I: What happened? S: The stream started out stronger	A S: 0.125units/sec
Malume	S: 2.6 seconds TOO LOW	A S: 32 seconds I: Why is this so different from your prediction? S: I don't know why...I think...it's...uh... pressure	A S: 0.125units/sec
Lwazi	unable	A S: 30 seconds I: What did you notice? S: they are the same... they come out fast and then slow, slow... at the top [of the bottle] – large flow rate; in middle – medium; lower – small	A S: 0.13units/sec

APPENDIX Y

Detailed Summary - Task 3, Subtask 4

S – Student

I - Interviewer

	PREDICT	Q1 - How long did it take for 4 units to flow out?	Q2 – what is the flow rate?
Ntando	<p>S: The flow rate will be less than this [indicates subtask 3] the water will be coming out of both holes... but sooner or later it will be coming out of one hole [points at bottom hole]... then it will be same pressure, in time it will be shorter</p> <p>PERFECT PREDICTION; CONCEPTUAL ERROR IN REASONING THOUGH</p>	<p>A S: 50 seconds I: What did you notice? S: it's dropping pressure [points at top hole], but the pressure is still going on in the one on the bottom ... pressure's out [pointing at top hole]... it's dropping pressure [pointing at bottom hole] I: we predicted shorter than the previous 27 seconds you predicted last time, why do you think it takes longer? S: I would say, because of the direction of the [points at holes] if it would be the same direction as these holes [previous example] it would be the same... but then it's the direction....It first dropped pressure in the one on top and then the water was taking long to come out the other one</p>	<p>A S: 0.08units/sec I: Why is this flow rate lower than for number [subtask] 3? S: are the holes the same?...isn't it because the pressure...because here you get [points at bottom hole]... the water goes out faster... and then this side [points at top hole] it's a little slower</p>
Kaden	<p>S: the flow's going to come out more [than subtask 3], but when it comes here [points at top hole] it's going to come out slower...but then it's going to go down [traces down bottle to below top hole]... then it's going to put pressure [points at bottom hole]</p> <p>CORRECT DESCRIPTION BUT</p>	<p>A S: 4 units in 50 seconds</p>	<p>A S: 0.08units/sec</p>

	NO PREDICTION OF TIME		
Mzwakhe	S: 20 seconds INCORRECT, SHOULD BE MORE TIME THAN ST3	S: 51 seconds [looks very surprised] I: Why do you think it is so much more than you predicted? S: because this one [bottom hole] had to wait for this one [top hole], and the water arrived earlier than this one [bottom]... there was the movement of ... and the speed changed... the pressure was not the same... was not enough... at the bottom the pressure was still pumping...	A S: 0.08units/sec S: Here [subtask 3]... water comes out same time, same speed... this one, there's this gap... the pressure was not the same. Here [top hole] not so much... the speed of the water...
Neliswa	S: 32 seconds CONCEPTUALLY OK, BECAUSE 1 SEC LONGER THAN SHE HAD FOR ST3, BUT TOO LOW	S: wow! It's 50 seconds I: Why is it more than you predicted? S: because only this one's [bottomhole] working more than this one [top hole]; [gestures with both hands pushing together to indicate pressure]	A S: 0.08units/sec S: so... the higher the pressure, the higher the flow rate ... the lower the flow rate the lower the pressure
Nobuhle	S: slower OK	A S: 54 seconds S: because this one has two holes, one on top, one on bottom... then this one (top) couldn't have anything coming out, but this one (bottom) could	A S: 0.07units/sec
Aviwe	S: 40 seconds REASONABLE: LONGER THAN ST3	A S: 53seconds I: Why is it more than you predicted? S: because of the distance of the holes... should the liquid go here [points at top hole] there will be one hole	A S: 0.08units/sec S: it's the pressure of the thing [gestures with both hands pushing together to indicate pressure], as the pressure increases the flow rate can be a little faster
Sisipho	S: I'm not sure... I'm not sure about the directions... this one [points at bottom hole]	A S: 58 seconds S: I should have guessed!	A S: 0.07units/sec

	<p>is going to slow down and this one [points at top hole] is going to stop</p> <p>EXPLANATION SOUND, NO PREDICTION THOUGH</p>		
Malusi	<p>S: 22 seconds</p> <p>INCORRECT, PREDICTED LESS THAN ST 3</p>	<p>A S: 41 seconds I: What did you notice? S: that this one [bottom hole] was pumping out... pumping out the water more than that one [top] and this one [top] was slower... and then this one [top] had no water; when we started there were 2 and then the water was in middle so only one</p>	<p>A S: 0.08units/sec</p>
Phumzile	<p>S: 20 seconds</p> <p>INCORRECT, LESS THAN FOR ST3</p>	<p>A S: 54 seconds I: Why do you think it took so much longer than you predicted? S: the first hole is on top therefore the second is on bottom therefore the pressure of the water... when the water... cos the pressure was increased when at top... as the water gets closer to this [top] hole the pressure is decreasing, and the hole at the bottom it's also decreasing</p>	<p>A S: 0.07units/sec</p>
Sandla	<p>S: shorter [than subtask 3]</p> <p>INCORRECT, LESS THAN ST 3</p>	<p>A S: 47 seconds I: Why did it take longer than for the previous question? S: because of this one [points at bottom hole], because it gets less [gestures to indicate a stream]... and the top one, it stopped</p>	<p>S: [uses calculator ... $47 \div 4$] I: C(m) [had done this correctly previously] S: 0.09units S: these ones [horizontal holes in subtask 3] are side by side... and this one [subtask 4] is up and one is down.</p>

		<p>I: What do you think the reason is for the change? S: the pressure [gestures with both hands pushing together to indicate pressure]</p>	<p>I: And so what happened? S: [points at top hole] started to flow so fast, as the water drops it slows and stops, doesn't function... here [subtask 3] both holes function</p>
Andiswa	<p>S: longer, because the two holes are too far away... because this one is at the bottom and this one is higher... and this one [top] will go faster than this one [bottom] (INCORRECT)</p> <p>PREDICTION CORRECT</p>	<p>A S: 48 seconds I: What did you notice? S: the top one, it was going slower and then the top one, neh? The top one was going fast and it was slowing down and the bottom one was going fast I: and by the end? S: it [bottom hole] was going slower</p>	<p>A S: 0.08units/sec</p>
Mkhuseli	<p>S: 20 seconds INCORRECT, SHORTER THAN ST3</p>	<p>A S: 54 secs I: What was happening? S: the top part is coming slow... it stopped... I: why? S: because the holes were drilled in different positions</p>	<p>A S: 0.07units/sec VIDEO STOPPED</p>
Babalwa	<p>S: ... longer... 40 seconds, because when the water reaches this one [top hole] it will only have one [hole] left CORRECT</p>	<p>A S: 60 secs</p>	<p>S: [uses calculator ... $60 \div 4$, then pauses] I: C(m) [had done this correctly previously] S: 0.07units/sec</p>
Samkelo	<p>S: [long pause] it will be... 50 I: Why did you guess 50? S: when it was there [points at horizontal holes from subtask 3] both of them still switched on... so now [subtask 4] with the pressure...flow...flow rate [pointing at the top hole] is dropping, so</p>	<p>A S: 56 sec I: What did you notice? S: flow rate was not the same, this is one [top] stops first</p>	<p>A S: [uses calculator ... $56 \div 4 = 14$, then pauses; self-corrects to do $4 \div 56 = 0.07$] 0.07units/sec</p>

	when it's here [top hole] then it [bottom hole] will be the one that pumps CORRECT		
Andile	S: smaller [flow rate] than horizontal [subtask 3] because this thing is full, when this pushes down through past this one [top hole] then there is one [hole] CORRECT	A S: 56 seconds	INTERVIEW TERMINATED: STUDENT UNREST (EVACUATED)
Sanele	S: the flow rate won't be the same as previous one, the top one [hole] will go fast and then when it reaches here [points at top hole] this one [bottom hole] will come out and this one [top] will not come out CORRECT BUT NO TIME PREDICTION	A S: 60 seconds, since it's going down the pressure getting less	A S: 0.07units/sec
Thandiwe	S: the time will be longer than horizontal [subtask 3] because this one's on top [points to top hole in relation to bottom hole]... and there's no more [gestures to indicate no more water] CORRECT	A S: 60 seconds	A S: 0.07units/sec
Linda	S: it is longer than horizontal [subtask 3] when it reaches here [top hole] this one's going to be open and won't go, it's only going to be on this side [points at bottom hole] CORRECT	A S: 51 seconds I: What did you notice? S: This amount here [points at top hole] it didn't come out so much... it's only this one [points at bottom hole]	A S: 0.08units/sec
Malume	S: 44 seconds	A S: 53 seconds I: What did you notice?	A S: 0.08units/sec

	REASONABLE, MORE THAN ST3	S: It stopped here [top hole] after a while and then it only used this one [bottom hole] and this one [bottom] was stronger	
Lwazi	20 seconds INCORRECT, LESS THAN ST3	A S: 49 seconds I: What did you notice? S: they come pressured water [point at top hole] and when we go here [top hole] this one goes down... they [bottom hole] don't get enough pressure of water...here [indicates subtask 2] we had a lot of pressure of water but not here [indicates subtasks 3 and 4] I: why do you think this flow rate is the lowest? S: we let it out for longer	A S: 0.08units/sec

APPENDIX Z

Performance per test item

Key: Measurement to be calculated

LINEAR	SURFACE AREA
AREA	VOLUME

Key: Symbols used

[F] – Full marks

[P] – Partial marks

[O] – Zero marks

[X] – Not attempted

STUDENT	ITEM NUMBER															
	1.1 (a)	1.1 (b)	1.2	1.3	2.1.1	2.1.2	2.2	2.3	3.1(a)	3.1(b)	3.2(a)	3.2(b)	3.3(a)	3.3(b)	3.4(a)	3.4(b)
ANDISWA	O	X	O	O	O	O	O	O	O	O	O	O	O	O	O	O
SANELE	O	O	O	O	O	O	O	O	X	P	X	O	X	O	X	O
NTANDO	O	X	O	O	O	O	O	O	P	X	P	X	O	X	O	X
SANDILE	P	O	O	X	O	O	X	O	O	O	O	O	O	O	O	O
KADEN	O	F	O	X	O	O	P	O	O	O	O	O	O	O	O	P
MALUSI	O	O	O	F	O	O	P	P	O	O	O	O	O	O	O	O
SAMKELO	F	O	P	X	O	O	P	O	X	O	X	O	X	O	X	O
ERROL	O	X	O	O	O	O	P	O	F	P	O	P	O	O	P	O
SANDLA	O	O	P	X	O	P	X	O	O	P	O	P	O	O	O	O
LIANA	O	O	F	O	P	O	X	X	F	P	X	O	X	P	O	O
MZWAKHE	O	F	P	O	F	O	X	O	F	O	X	P	O	O	P	O
THANDIWE	F	P	F	F	X	O	X	X	O	P	O	P	O	O	O	O
BONELWA	O	F	P	O	P	O	O	O	F	O	F	F	O	O	O	O
ANDILE	P	F	O	O	X	X	X	P	O	O	F	P	O	O	F	O
BABALWA	P	F	O	F	F	O	X	O	F	O	O	P	O	O	P	O
NOBUHLE	F	F	F	F	O	O	O	O	F	F	O	O	O	O	O	P
PHUMZILE	O	O	X	X	O	O	O	F	F	F	F	P	O	O	X	F
SISIPHO	F	F	O	F	O	O	O	O	F	F	O	O	O	O	O	F
NDILEKA	F	F	F	F	O	O	O	O	F	X	O	O	O	O	F	P
TSHAWA	O	F	P	F	O	F	P	O	F	P	F	P	O	O	O	P
ANATHI	F	F	O	F	O	F	O	O	F	O	F	O	O	O	F	O
LINDIWE	F	F	O	F	O	O	P	F	F	O	F	O	O	O	P	P
NELISWA	F	F	O	F	F	O	O	O	F	O	F	P	O	O	F	P
SIYABULELA	F	F	F	O	F	F	X	O	F	P	F	P	O	O	X	P
LUMKO	F	F	F	O	F	O	O	O	F	O	F	F	X	O	F	F
AVIWE	F	P	P	P	F	O	P	F	F	F	O	O	O	O	F	F
MTHOBELI	O	F	F	F	F	O	O	F	F	O	F	P	O	O	F	O
[F] Full Marks	11	15	7	11	7	3	0	4	17	4	10	2	0	0	7	4
[P] Partial Marks	3	2	6	1	2	1	7	2	1	7	1	11	0	1	4	7
[O] Zero Marks	13	7	13	10	16	22	12	19	7	14	12	13	23	25	12	15
[X] Left Out	0	2	1	5	2	1	8	2	2	2	4	1	4	1	4	1

APPENDIX AA

Detailed summary of use of incorrect formulae

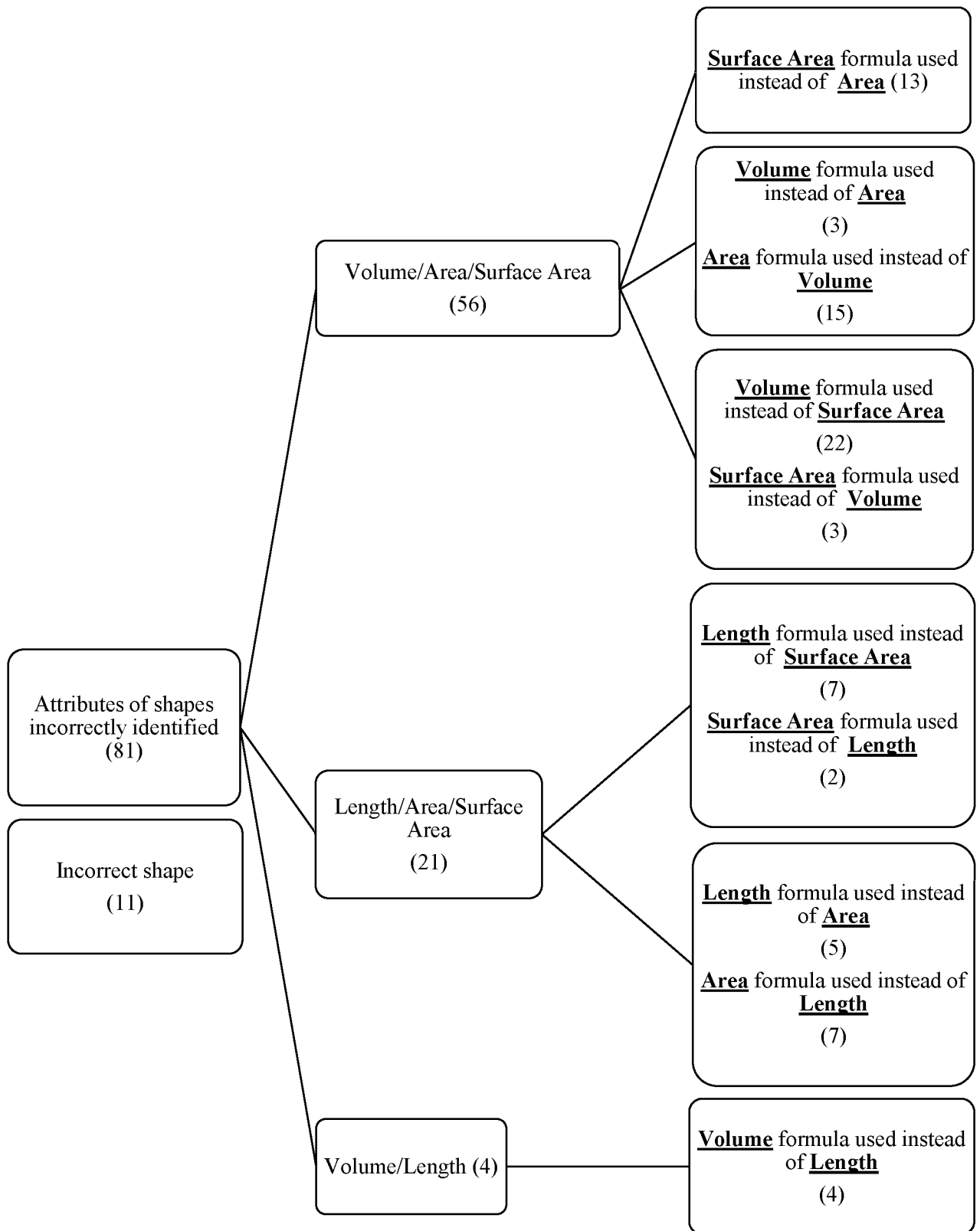

GLOSSARY OF ABBREVIATIONS AND ACRONYMS

(in order of appearance)

TVET	Technical and Vocational Education and Training
ECSA	Engineering Council of South Africa
DHET	Department of Higher Education and Training
FET	Further Education and Training
PME	International Group for the Psychology of Mathematics Education
ICME	International Congress on Mathematics Education
SA	South Africa
NC(V)	National Certificate (Vocational)
NSDSIII	National Skills Development Strategy III
RSA	Republic of South Africa
NDP	National Development Plan
NPC	National Planning Commission
HRDCSA	Human Resource Development Council of South Africa
StatsSA	Statistics South Africa
NEET	Not in Education, Employment or Training
NSC	National Senior Certificate
NQF	National Qualifications Framework
SAQA	South African Qualifications Authority
ABET	Adult Basic Education and Training
RPL	Recognition of Prior Learning
UNESCO	United Nations Educational, Scientific and Cultural Organisation
NADSC	National Artisan Development Support Centre
SETA	Sector Education Training Authorities
LoLT	Language of Learning and Teaching
TIMSS	Trends in Mathematics and Science Studies
PIRLS	Progress in International Reading Study
SACMEQ	Southern and Eastern African Consortium for Monitoring Educational Quality
ANA	Annual National Assessments
UNEVOC	International Centre for Technical and Vocational Education and Training
CIP	Colleges Improvement Project
JET	Joint Education Trust
DBE	Department of Basic Education

EC	Eastern Cape
GT	Gauteng
WC	Western Cape
FS	Free State
KZ	KwaZulu Natal
LP	Limpopo
MP	Mpumalanga
NC	Northern Cape
NW	North West
IP	Intermediate Phase
SP	Senior Phase
FP	Foundation Phase
SI	Système International
ZPD	Zone of Proximal Development
3D	Three-dimensional
LPCAT	Learning Potential Computerised Adaptive Test
GPAM	Graduated Prompting Assessment Module
A	No mediation
B	Reassurance
C	Prompt
D	Leading Question
E	Instruction
F	Correction
(m)	method
(c)	concept
S _n :	Student Action/Utterance
M _n :	Interviewer Mediation
O _n :	Informal Observation
A:	No mediation
B:	Reassurance
C(m):	Prompt (method)
C(c):	Prompt (conceptual)
P(a):	Provision of an additional artefact
D(m):	Leading question (method)
D(p):	Leading question (process)

D(c):	Leading question (conceptual)
R(a):	Reference made to artefact
E(m):	Instruction (method)
E(c):	Instruction (conceptual)
F(m):	Correction (method)
F(c):	Correction (conceptual)
RA	Rectangular array
RD	Drawing rectangles of decreasing size
IR	Iterating in rows
IP	Iteration around inside perimeter
EA	Extends into irregular area
LR	Label with rational number
LD	Label with decimal
CW	Combine mentally
PW	Partial unit added as whole
F	Full marks
P	Partial marks
O	Zero marks
X	Not attempted